

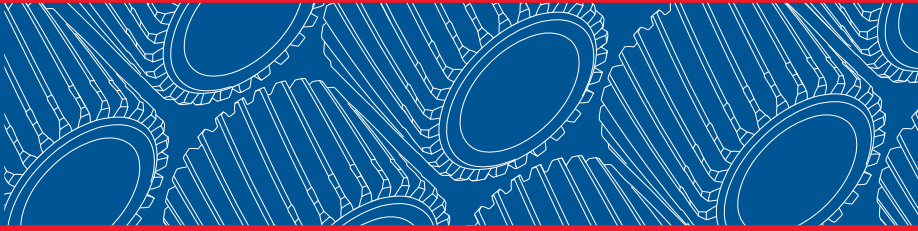

**Allison**  
**Transmission**



# **Operator's Manual**

**3000 and 4000  
Product Families**

**International Models**

**OM4119EN**

# Operator's Manual

2008 MAY

OM4119EN

## Allison Transmission

### INTERNATIONAL MODELS

3000 and 4000 Product Families  
Allison 4<sup>th</sup> Generation Controls  
and Model Year 2009 Prognostics

3000			3000 SP
3200	3200 MH	3200 ORS	3200 SP
3500		3500 ORS	3500 SP
3700			3700 SP
4000	4000 MH	4000 ORS	4000 SP
		4200 ORS	
		4430 ORS	
		4440 ORS	
4500		4500 ORS	4500 SP
		4600 ORS	
4700		4700 OFS	4700 SP
4800			4800 SP



Allison Transmission, Inc.  
P.O. Box 894 Indianapolis, Indiana 46206-0894  
[www.allisontransmission.com](http://www.allisontransmission.com)

# NOTES

# TABLE OF CONTENTS

## INTRODUCTION

KEEPING THAT ALLISON ADVANTAGE . . . . .	7
A BRIEF DESCRIPTION OF THE ALLISON TRANSMISSION . . . . .	10
ALLISON 4 <sup>TH</sup> GENERATION ELECTRONIC CONTROL SYSTEM . . . . .	15
ALLISON 4 <sup>TH</sup> GENERATION MODEL YEAR 2009 PROGNOSTICS FUNCTIONS . . . . .	16
TORQUE CONVERTER . . . . .	18
PLANETARY GEARS AND CLUTCHES . . . . .	19
COOLER CIRCUIT . . . . .	19
RETARDER . . . . .	19
TRANSFER CASE (DROPBOX) . . . . .	19

## SHIFT SELECTORS

INTRODUCTION . . . . .	21
DESCRIPTION OF AVAILABLE ALLISON 4 <sup>TH</sup> GENERATION SHIFT SELECTOR TYPES . . . . .	21
DESCRIPTION OF AVAILABLE ALLISON 4 <sup>TH</sup> GENERATION MY09 PROGNOSTICS SHIFT SELECTOR TYPES . . . . .	27
RANGE SELECTION . . . . .	33

## DRIVING TIPS

CHECK TRANS LIGHT . . . . .	39
DIAGNOSTIC CODES OVERVIEW . . . . .	40
ALLISON 4 <sup>TH</sup> GENERATION CONTROLS DIAGNOSTIC CODE DISPLAY PROCEDURE . . . . .	41
ALLISON 4 <sup>TH</sup> GENERATION MY09 PROGNOSTICS DIAGNOSTIC CODE DISPLAY PROCEDURE . . . . .	43
ACCELERATOR CONTROL . . . . .	46
RANGE SHIFTS AND INHIBITS . . . . .	46
USING THE ENGINE TO SLOW THE VEHICLE . . . . .	47
USING THE HYDRAULIC RETARDER . . . . .	48
RANGE PRESELECTION . . . . .	52
COLD WEATHER STARTS . . . . .	52
DRIVING ON SNOW OR ICE . . . . .	53
ROCKING OUT . . . . .	53
HIGH FLUID TEMPERATURE . . . . .	54
PARKING BRAKE . . . . .	55
TOWING OR PUSHING . . . . .	55
TURNING OFF THE VEHICLE . . . . .	55
PRIMARY/SECONDARY SHIFT SCHEDULES . . . . .	56
CRUISE CONTROL OPERATION . . . . .	56

OPERATING DOWN STEEP GRADES (REAR-DISCHARGE MIXER) . . . . .	57
---	----

## **POWER TAKEOFF OPERATION**

ENGINE-DRIVEN POWER TAKEOFF (PTO) . . . . .	58
---	----

## **CARE AND MAINTENANCE**

PERIODIC INSPECTIONS . . . . .	59
PREVENT MAJOR PROBLEMS . . . . .	59
IMPORTANCE OF PROPER FLUID LEVEL . . . . .	60
ALLISON 4 <sup>TH</sup> GENERATION MY09 PROGNOSTICS DISABLED AND SEVEN SPEED TRANSMISSION FLUID LEVEL CHECK USING ALLISON SHIFT SELECTORS . . . . .	60
PROGNOSTICS FUNCTIONALITY FOR MODEL YEAR 2009 . . . . .	64
ALLISON 4 <sup>TH</sup> GENERATION MY09 PROGNOSTICS ENABLED FLUID LEVEL CHECK USING ALLISON SHIFT SELECTORS . . . . .	67
FLUID LEVEL CHECK USING DIAGNOSTIC TOOLS . . . . .	72
MANUAL FLUID CHECK PROCEDURE . . . . .	73
COLD CHECK . . . . .	75
HOT CHECK . . . . .	76
RECOMMENDED AUTOMATIC TRANSMISSION FLUID AND VISCOSITY GRADE . . . . .	76
KEEPING FLUID CLEAN . . . . .	78
ALLISON 4 <sup>TH</sup> GENERATION AND MY09 PROGNOSTICS DISABLED FLUID AND INTERNAL FILTER CHANGE INTERVAL RECOMMENDATIONS . . . . .	78
ALLISON 4 <sup>TH</sup> GENERATION MY09 PROGNOSTICS ENABLED FLUID AND FILTER CHANGE INTERVAL RECOMMENDATIONS . . . . .	85
FLUID ANALYSIS . . . . .	87
REFILL TRANSMISSION . . . . .	87

## **DIAGNOSTICS**

DIAGNOSTIC CODES . . . . .	88
----------------------------	----

## **CUSTOMER SERVICE**

OWNER ASSISTANCE . . . . .	90
SERVICE LITERATURE . . . . .	92
ALLISON TRANSMISSION REGIONAL OFFICES . . . . .	93

## **TRADEMARK USAGE**

The following trademarks are the property of the companies indicated:

- Allison DOC™ is a trademark of General Motors Corporation.
- DEXRON® is a registered trademark of the General Motors Corporation.

## WARNINGS, CAUTIONS, NOTES

**IT IS YOUR RESPONSIBILITY** to be completely familiar with the warnings and cautions described in this manual. It is, however, important to understand that these warnings and cautions are not exhaustive. Allison Transmission could not possibly know, evaluate, and advise the service trade of all conceivable ways in which service might be done or of the possible hazardous consequences of each way. The vehicle manufacturer is responsible for providing information related to the operation of vehicle systems (including appropriate warnings, cautions, and notes). Consequently, Allison Transmission has not undertaken any such broad evaluation. Accordingly, **ANYONE WHO USES A SERVICE PROCEDURE OR TOOL WHICH IS NOT RECOMMENDED BY ALLISON TRANSMISSION OR THE VEHICLE MANUFACTURER MUST** first be thoroughly satisfied that neither personal safety nor equipment safety will be jeopardized by the service methods selected.

Proper service and repair is important to the safe, reliable operation of the equipment. The service procedures recommended by Allison Transmission (or the vehicle manufacturer) and described in this manual are effective methods for performing service operations. Some of these service operations require the use of tools specially designed for the purpose. The special tools should be used when and as recommended.

Three types of headings are used in this manual to attract your attention. These warnings and cautions advise of specific methods or actions that can result in personal injury, damage to the equipment, or cause the equipment to become unsafe.



**WARNING:** A warning is used when an operating procedure, practice, etc., if not correctly followed, could result in personal injury or loss of life.



**CAUTION:** A caution is used when an operating procedure, practice, etc., if not strictly observed, could result in damage to or destruction of equipment.



**NOTE:** A note is used when an operating procedure, practice, etc., is essential to highlight.

---

# INTRODUCTION

---

## KEEPING THAT ALLISON ADVANTAGE



V01724

**Allison 3000 and 4000 Product Families** transmissions are rugged and designed to provide long, trouble-free service.

This handbook will help the operator gain the maximum benefits from an Allison transmission-equipped vehicle.



## Abbreviations

ABS	Anti-lock Brake System
DMD	Display Mode/Diagnostic
DOC	Diagnostic Optimized Connection
DTC	Diagnostic Trouble Code
ECU	Electronic Control Unit
EMI	Electromagnetic Interference
FCC	Federal Communications Commission
FM	Filter Life Monitor
I/O	Input/Output
KOH	Potassium Hydroxide
MY09	Model Year 2009
OEM	Original Equipment Manufacturer
OLS	Oil Level Sensor
OM	Oil Life Monitor
PTO	Power Takeoff
PWM	Pulse Width Modulated
RFI	Radio Frequency Interference
RMR	Retarder Modulation Request
SP	Specialty Series
TAN	Total Acid Number
TM	Transmission Health Monitor
TPS	Throttle Position Sensor
VIM	Vehicle Interface Module

Your Allison transmission has one of two electronic control systems: Allison 4<sup>th</sup> Generation Controls, or Allison 4<sup>th</sup> Generation MY09 Prognostics Controls. The current electronic control system being offered is Allison 4<sup>th</sup> Generation MY09 Prognostics Controls. The MY09 Prognostics functions of this control system are explained in Section 3, DRIVING TIPS and Section 5, CARE AND MAINTENANCE. The operation of the shift selectors is explained in Section 2, SHIFT SELECTORS.

Refer to the shift selectors shown in Figure 1 and Figure 2 to identify which system is installed in your transmission. The Allison 4<sup>th</sup> Generation Controls shift selectors have two LED digital displays (refer to Figure 1). The Allison 4<sup>th</sup> Generation MY09 Prognostics Controls shift selectors have two LED digital displays and a service icon in the form of an open-end wrench between the digital displays (refer to Figure 2).

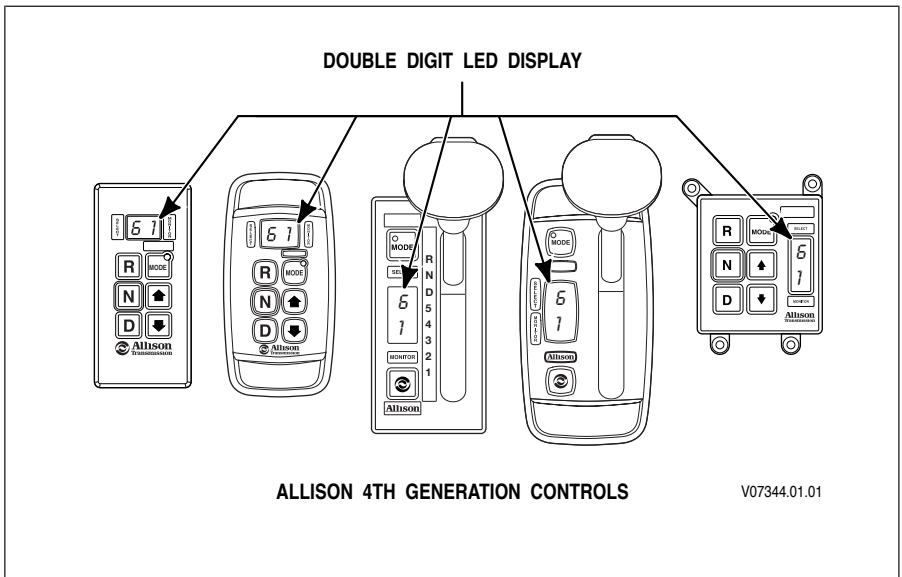

**Figure 1. Typical Allison 4<sup>th</sup> Generation Controls Shift Selectors With SELECT And MONITOR Digital Displays**

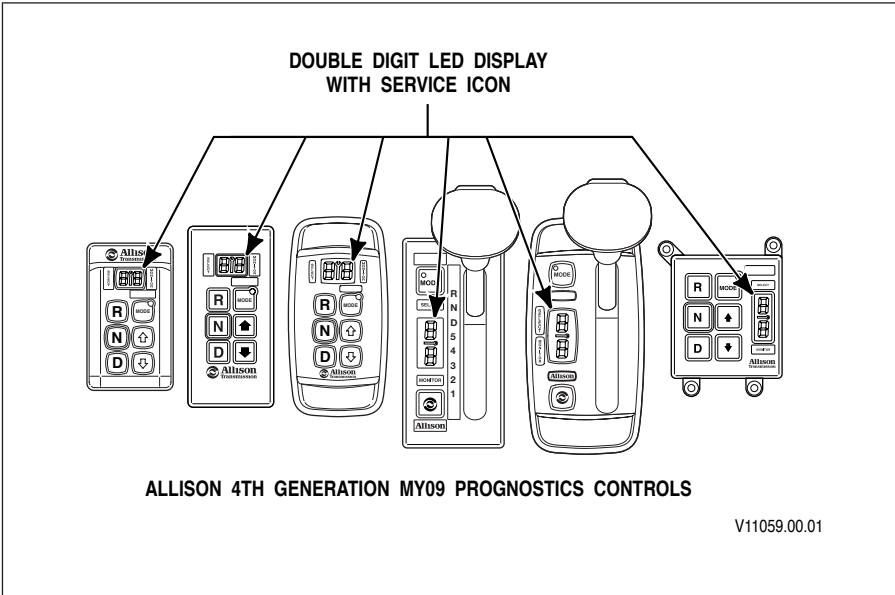

**Figure 2. Typical Allison 4<sup>th</sup> Generation MY 09 Prognostics Controls Shift Selectors With SELECT And MONITOR Digital Displays and Service Icon (open-end wrench)**

## **A BRIEF DESCRIPTION OF THE ALLISON TRANSMISSION**

The Allison transmissions (refer to Figure 3 through Figure 6) described in this manual include:

- Allison 4<sup>th</sup> Generation Controls
- Allison 4<sup>th</sup> Generation MY09 Prognostics (not available on earlier model years)
- A torque converter with lockup clutch and torsion damper
- Three planetary gear sets (four for 4700 OFS/SP and 4800 SP)
- Five clutches (six for 4700 OFS/SP and 4800 SP)

An integral retarder is available as an option on all transmissions. A provision to mount a power takeoff (PTO) is available as an option on all transmissions.



**NOTE:** Allison electronic controls are designed and manufactured to comply with all FCC and other guidelines regarding radio frequency interference/electromagnetic interference (RFI/EMI) for transportation electronics. Manufacturers, assemblers, and installers of radio-telephone or two-way communication radios have the sole responsibility to correctly install and integrate those devices into Allison transmission-equipped vehicles to customer satisfaction.

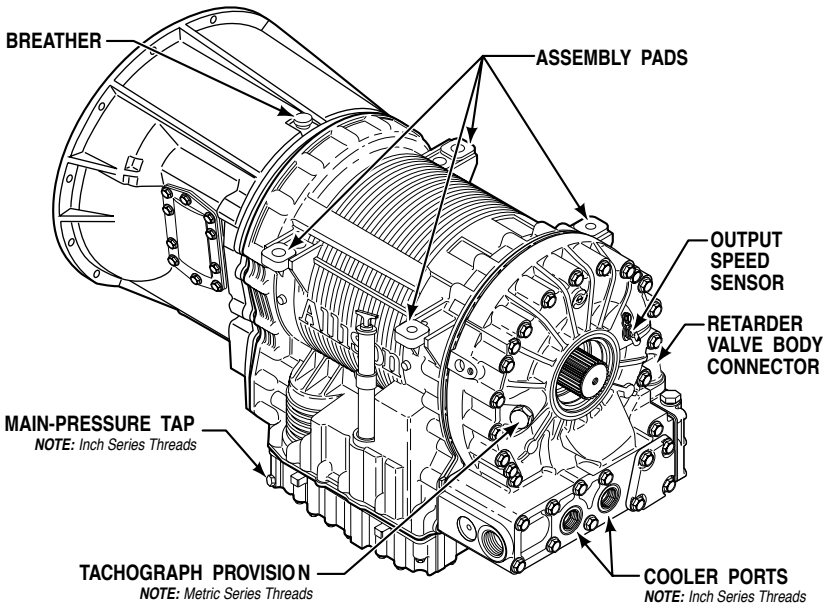

### LEFT-REAR VIEW

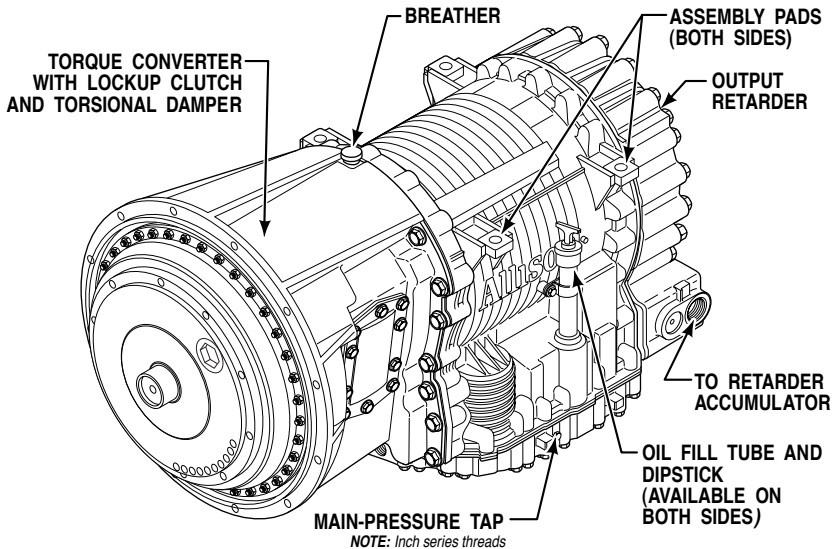

### LEFT-FRONT VIEW

V07307.02.00

**Figure 3. 3200/3500 Model With Retarder  
(Allison 4<sup>th</sup> Generation Controls)**

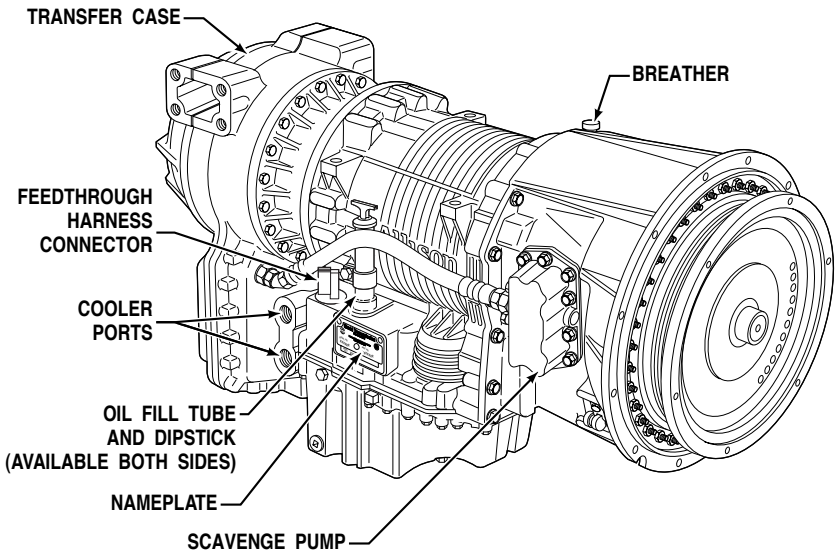

**RIGHT-FRONT VIEW**

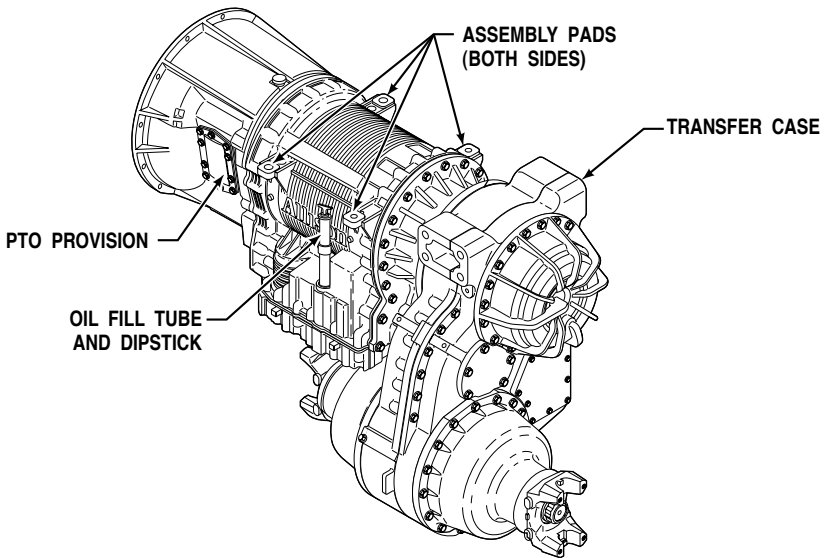

**LEFT-REAR VIEW**

V08626.01.01

**Figure 4. 3700 SP With PTO (Allison 4<sup>th</sup> Generation Controls)**

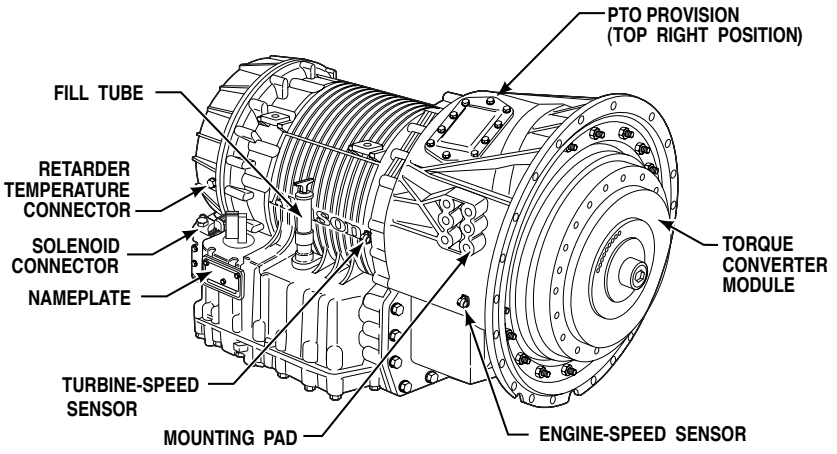

**RIGHT-FRONT VIEW**

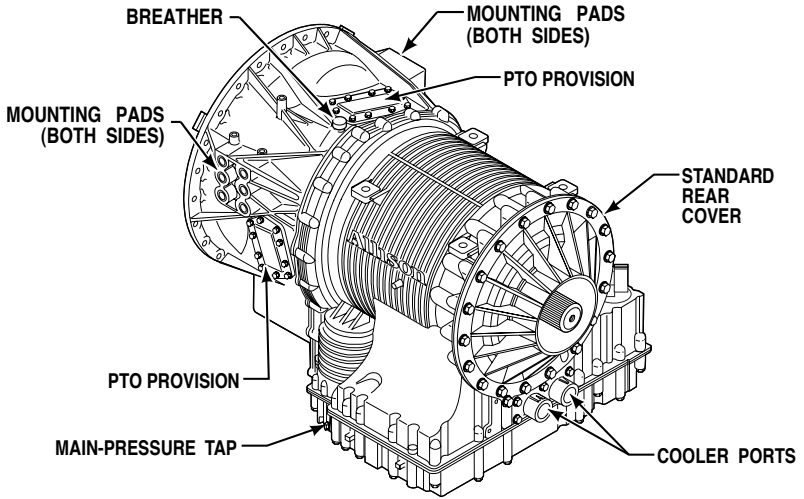

**LEFT-REAR VIEW**

V10695.00.01

**Figure 5. 4000/4500 Model With PTO  
(Allison 4<sup>th</sup> Generation Controls)**

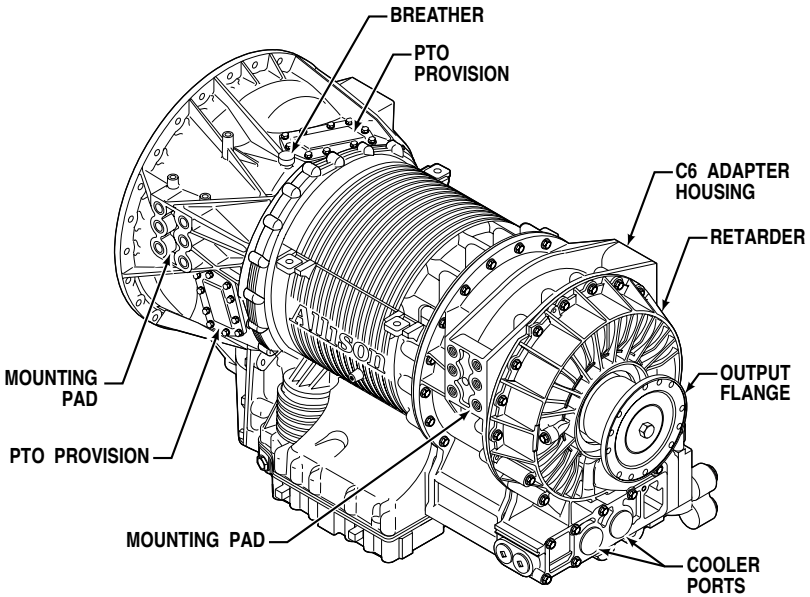

**LEFT-REAR VIEW**

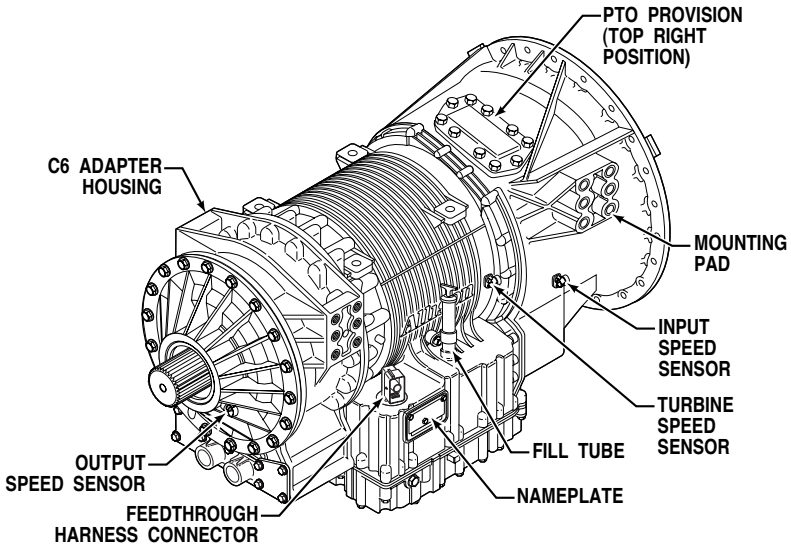

**RIGHT-REAR VIEW**

V08619.01.01

**Figure 6. 4700/4800 SP and OFS With PTO And Retarder  
(Allison 4<sup>th</sup> Generation Controls)**

The TCM/ECU is programmed to provide the most suitable operating characteristics for a specific application. This manual does not attempt to describe all of the possible combinations. The information contained herein describes only the operating characteristics most frequently requested by vehicle manufacturers.

## **ALLISON 4<sup>TH</sup> GENERATION ELECTRONIC CONTROL SYSTEM**

Allison 4<sup>th</sup> Generation Controls consist of the following major components connected by an OEM-furnished wiring harness:

- Transmission Control Module (TCM)
- Three speed sensors (refer to Figure 3 through Figure 6):
  - Input
  - Turbine
  - Output
- Remote shift selector
- Control module which includes:
  - Solenoids
  - Diagnostic pressure switch
  - Oil level sensor (standard on the 3000 and 4000 Product Family transmissions through six-speed, optional on the 4700 OFS/SP and 4800 SP, and not available on 3700 SP)
  - Sump temperature sensor
  - Valves
  - Internal wire harnesses
- Optional Allison Throttle Position Sensor (TPS)

The TCM processes information and then sends signals to actuate specific solenoids located in the control module. These solenoids control clutch pressures to provide closed-loop control. The closed-loop control makes “during shift” adjustments. These adjustments in shift characteristics are based on vehicle conditions such as grade, load, and engine power. After a shift is completed, the TCM compares the shift to an “ideal” shift profile in the TCM calibration and makes adjustments before the next shift of the same kind is made. This is “adaptive logic” which establishes initial conditions for shifts.

The Allison 4<sup>th</sup> Generation Control has an “autodetect” feature. Autodetect is active within the first 30 seconds of the first 24 engine starts or 49 engine starts, depending upon the component or sensor being detected. Autodetect searches for the presence of the following transmission components or data inputs.



Retarder	Present, Not Present
Oil Level Sensor (OLS)	Present, Not Present
Throttle*	Analog, J1587, J1939
Engine Coolant Temperature	Analog, J1587, J1939
* A pulse width modulated (PWM) throttle source is not "autodetected." This source requires a unique calibration or can be manually selected using Allison DOC™ For PC–Service Tool.	

Even though autodetect has been completed, it can be reset to monitor an additional group of engine starts. Reset may be necessary if a device known to be present is not detected or if an autodetectable component or sensor was added after the initial vehicle build.

Reset is accomplished by using the Allison DOC™ For PC–Service Tool. The Allison DOC™ For PC–Service Tool may also be used to override autodetect and manually enter the component or sensor to be recognized by the TCM by changing appropriate "customer modified constants."

## ALLISON 4<sup>TH</sup> GENERATION MODEL YEAR 2009 PROGNOSTICS FUNCTIONS

Allison Transmission, Inc. has introduced three new diagnostic parameters that are available only on 3-, 4-, 5-, and 6-speed transmissions for Model Year 2009 (MY09). These new diagnostic parameters will provide indicators of required maintenance actions and are named "Prognostics" because they predict required transmission maintenance. These new Prognostics include the following:

- Oil Life Monitor (OM)
- Filter Life Monitor (FM)
- Transmission Health Monitor (TM)

Prognostics are designed to maximize fluid (the terms oil and fluid are used interchangeably) and filter utilization and provide an early indication of clutch system concerns so that an inspection may be scheduled before a clutch fails and causes other transmission damage.

The following items are required to allow MY09 Prognostics:

- **Allison approved TES 295 transmission fluid and Allison High Capacity Filters.**
- Transmission with filter life valve body and pressure switch.
- MY09 TCM.
- Filter pressure switch wiring in the OEM wiring harness from the transmission to the TCM.
- MY09 Allison pushbutton or lever shift selector or an OEM installed shifter plus a service indicator light or J1939 text message display. The OEM service indicator light may also be used with a J1939 text messaging display.

Allison MY09 shift selectors contain an integrated service icon in the shape of an open-end wrench located between the SELECT and MONITOR displays (refer to DESCRIPTION OF AVAILABLE TYPES in the SHIFT SELECTOR section).

The vehicle manufacturer specifies whether the Allison Prognostics Feature is made available in the calibration and, if so, whether the Prognostic function is defaulted ON or OFF for customer use. The transmission calibration can be made for the vehicle manufacturer (or the customer) so that the prognostics feature is in one of the following states:

- Available and the function is defaulted ON
- Available but the function is defaulted OFF



**NOTE:** An Allison service outlet can assist with programming Prognostics ON at customer expense if Allison requirements are met prior to Prognostics features being turned ON.

---

- Not available in the transmission calibration.



**NOTE:** An Allison service outlet can assist with a transmission calibration change so that MY09 Prognostics are available at customer expense if Allison requirements are met prior to TCM recalibration.

---

The three Prognostics functions are enabled or disabled as a group and cannot be enabled or disabled individually. The OEM may also specify whether Prognostics may be reset by the Allison shift selector, J1939 message, or only with the use of the Allison DOC™ For PC–Service Tool.



**CAUTION: Prognostics requires the use of Allison approved TES 295 fluids and Allison High Capacity Filters if turned ON.** If any other fluids or filters are used, the Prognostics feature **MUST BE** turned OFF. Prognostics information will not be accurate with any other transmission fluids and could result in missed maintenance activities resulting in transmission damage. If Prognostics functions are not programmed or are turned OFF, refer to the miles/hours/months fluid and filter change interval charts in the CARE AND MAINTENANCE section or visit [www.allisontransmission.com](http://www.allisontransmission.com), click Service, Fluid/Filter Change Interval, then Fluids, and read the current revision of Service Tips 1099 for details.

The Allison 4<sup>th</sup> Generation Controls has an “autodetect” feature. Autodetect is active within the first 30 seconds of the first 24 engine starts or 49 engine starts, depending upon the component or sensor being detected. Autodetect searches for the presence of the following transmission components or data inputs.

Retarder	Present, Not Present
Oil Level Sensor (OLS)	Present, Not Present
Throttle*	Analog, J1587, J1939
Engine Coolant Temperature	Analog, J1587, J1939
* A pulse width modulated (PWM) throttle source is not “autodetected.” This source requires a unique calibration or can be manually selected using Allison DOC™ For PC–Service Tool.	

Even though autodetect has been completed, it can be reset to monitor an additional group of engine starts. Reset may be necessary if a device known to be present is not detected or if an autodetectable component or sensor was added after the initial vehicle build.

Reset is accomplished by using the Allison DOC™ For PC–Service Tool. The Allison DOC™ For PC–Service Tool may also be used to override autodetect and manually enter the component or sensor to be recognized by the TCM by changing appropriate “customer modified constants.”

## TORQUE CONVERTER

The torque converter consists of the following four elements:

- Pump—input element driven directly by the engine
- Turbine—output element hydraulically driven by the pump
- Stator—reaction (torque multiplying) element
- Lockup Clutch—mechanically couples the pump and turbine when engaged; controlled by TCM/ECU

When the pump turns faster than the turbine and the stator is stationary, the torque converter is multiplying torque. When the turbine approaches the speed of the pump, the stator starts to rotate with the pump and turbine. When this occurs, torque multiplication stops and the torque converter functions as a fluid coupling.

The lockup clutch is located inside the torque converter and consists of the following elements:

- Piston and backplate—driven by the engine
- Clutch plate/damper (located between the piston and the backplate)—splined to the converter turbine

The lockup clutch/torsional damper is engaged and released in response to electronic signals from the TCM/ECU. Lockup clutch engagement provides a direct drive from the engine to the transmission input. This eliminates converter slippage and maximizes fuel economy and vehicle speed. The lockup clutch releases at lower speeds or when the TCM/ECU detects conditions requiring it to be released.

The torsional damper tries to absorb engine torsional vibration to attempt to prevent transmitting engine torsional vibration on through to transmission components (clutches, etc), or items bolted to the transmission (PTO, etc.).

## **PLANETARY GEARS AND CLUTCHES**

A series of three helical, constant mesh planetary gear sets (four for 4700 OFS/SP and 4800 SP) and shafts provides the mechanical gear ratios and direction of travel for the vehicle. The planetary gear sets are controlled by five multi-plate clutches (six for 4700 OFS/SP and 4800 SP) that work in pairs to produce up to six forward speeds (seven for 4700 OFS/SP and 4800 SP) and one reverse speed. The clutches are applied and released hydraulically in response to electronic signals from the TCM/ECU to the appropriate solenoids.

## **COOLER CIRCUIT**

The transmission fluid is cooled by an integral (transmission-mounted) or remote-mounted oil cooler. Connections to the cooling circuit are located at the front or rear of the transmission to facilitate installation of remote cooler lines. On retarder models, only the rear cooler ports may be used. The integral cooler is mounted on the lower rear portion of the transmission, replacing the remote cooler manifold. Integral cooler oil ports are internal requiring coolant to be routed to and from the cooler.

The retarder housing allows the addition of either a remote or integral cooler for transmission sump fluid in addition to retarder out fluid. A bypass cover is placed over the sump cooling ports when the provision is not used. The sump cooler ports are located on the lower right rear face of the retarder housing (refer to Figure 3 through Figure 6).

## **RETARDER**

The self-contained retarder is at the output of the transmission and consists of a vaned rotor which rotates in a vaned cavity. The rotor is splined to and driven by the output shaft. When the retarder is activated, the fluid in the accumulator is displaced into the retarder cavity. The pressurized fluid in the cavity acting against the rotating and stationary vanes causes the retarder rotor and output shaft to reduce speed, slowing the vehicle or limiting speed on a downhill grade. Refer to USING THE HYDRAULIC RETARDER for additional information.

When the retarder is deactivated, the retarder cavity is evacuated and the accumulator is recharged with fluid.

## **TRANSFER CASE (DROPBOX)**

A transfer case (dropbox) module is provided for 3700 SP-equipped vehicles where front and rear wheel drive is desired. The transfer case (refer to Figure 4) is

merged with a six-speed close ratio gear train to produce a 7-speed configuration. One of the two PTO drive provisions actuates a scavenge pump for the transfer case. A remote-mounted cooler is required for a dropbox unit.

Transfer case design features include helical transfer gears and a self-contained lubrication oil pump. The transfer gears provide a ratio of 1.2:1. The lubrication oil pump is driven directly by the output to the drive axles. Since lubrication is present whenever the drive axle is turning, it is not necessary to disconnect the drivelines or axle shafts when the vehicle is towed or pushed. A torque proportioning differential gives a front/rear torque split of 30/70 when the differential clutch (C7) is not engaged. When the multiplate differential clutch is engaged, the torque split becomes 50/50. The differential clutch is engaged in difficult traction situations.

The seventh forward speed in this transmission is the lowest numerical gear ratio provided and is intended for use in off-road conditions. This range is obtained when a multi-plate clutch (C6) in the transfer case is applied.

---

# SHIFT SELECTORS

---

## INTRODUCTION

Vehicle manufacturers may choose different types of shift selectors for their vehicles. The shift selector in your Allison-equipped vehicle will be similar to one of the pushbutton or lever styles (refer to Figure 7 and Figure 8) shown in the following sections that explain each Allison shift selector.

Allison transmissions can be programmed to have up to six (seven for 4700 OFS/SP and 4800 SP) forward ranges. Shift selector positions should agree with the programming of the TCM/ECU.

With an Allison-equipped vehicle, it is not necessary to select the right moment to upshift or downshift during changing road and traffic conditions. The Allison transmission does it for you. However, knowledge of the shift selector positions, available ranges, and when to select them make vehicle control and your job even easier. To reduce wear on service brakes, select lower ranges when descending long grades (with or without retarder). Refer to the Range Selection table at the end of this section for related information.

## DESCRIPTION OF AVAILABLE ALLISON 4<sup>TH</sup> GENERATION SHIFT SELECTOR TYPES

---



**NOTE:** This section is for Allison 4<sup>th</sup> Generation Controls, Model Year 2009 Prognostics **DISABLED**, and seven-speed transmissions which don't have Prognostics.

---

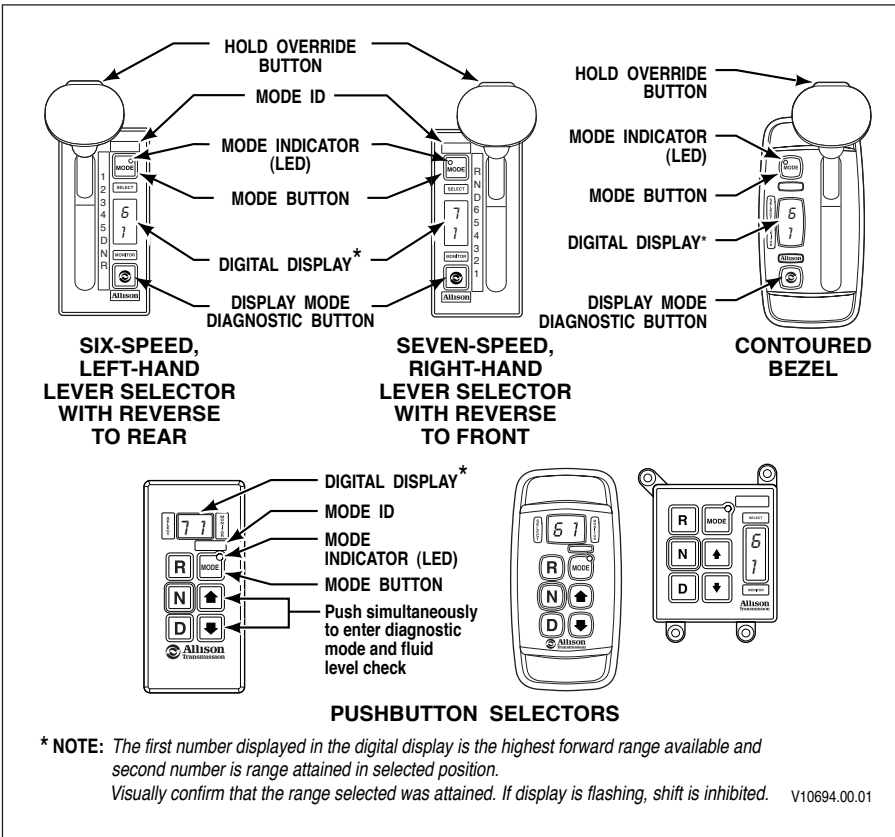

**Figure 7. Typical Allison 4<sup>th</sup> Generation Controls Shift Selectors**

**LEVER SHIFT SELECTOR.**

**General Description.** The Allison 4<sup>th</sup> Generation lever shift selector (refer to Figure 7) is an electromechanical control. Typical lever positions are:

- **R** (Reverse)
- **N** (Neutral)
- **D** (Drive)
- Some number of lower forward range positions

Allison transmissions can be programmed to have up to six (seven for 4700 OFS/SP and 4800 SP) forward ranges. Shift selector positions should agree with the programming of the TCM.

The lever shift selector includes the following:

- **HOLD OVERRIDE** button
- **MODE** button

- Digital display
- **DISPLAY MODE/DIAGNOSTIC** button

**Hold Override Button.** The lever shift selector has three locked positions to prevent accidentally selecting **R** (Reverse), **N** (Neutral), or **D** (Drive). Select **R** (Reverse), **N** (Neutral), or **D** (Drive) by pressing the **HOLD OVERRIDE** button and moving the lever to the desired position. Once **D** (Drive) is selected, lower forward range positions may be selected without pressing the **HOLD OVERRIDE** button.

**MODE Button.** The **MODE** button can allow the driver to enable a secondary shift schedule, PTO enable, or other special functions that have been programmed into the TCM unit at the request of the OEM. For example, a vehicle OEM may have provided a secondary shift schedule for improved fuel economy. The name of the special function (ECONOMY) appears on the MODE ID label adjacent to the **MODE** button. Pressing the **MODE** button activates the ECONOMY shift schedule and illuminates the MODE INDICATOR LED.

When the Diagnostic Display Mode has been entered, the **MODE** button is used to view and toggle through diagnostic code information. The code displayed is active if the MODE INDICATOR LED is illuminated.



**NOTE:** Visually observe the digital display whenever the lever is moved. **N** should appear in the digital display if **N** is selected.

---

**Digital Display.** Allison 4<sup>th</sup> Generation Controls contain two digital displays, SELECT and MONITOR. During normal operation, if **D** (Drive) is selected, the SELECT digital display shows the highest forward range attainable for the shift schedule in use. The MONITOR digital display shows the lowest available forward range.

Limited operation is indicated by the digital display as follows:

- All digital display segments are illuminated during initialization. If after 10 seconds communication is not established with the TCM, both digital displays show  $\backslash$  (cateries).
- When both digital displays show  $\backslash$  (cateries), a selector-related fault code has been logged.
- When the SELECT display shows **R** or **D** has been requested and the display is flashing the selected range, then the selected range has not been attained due to an inhibit function. Refer to RANGE SHIFTS AND INHIBITS in the DRIVING TIPS section.
- Inhibited range, shown by a flashing SELECT digital display, is not an indication that there is a transmission condition or problem, nor does it indicate that a DTC has set. An inhibit means there is a vehicle or engine condition that won't allow range selection or direction change such as:



- Too high idle speed in **N** to allow **R** or **D**
- Too high a throttle signal in **N** to allow **R** or **D**
- Too high of an output speed in **N** to allow **R** or **D**
- An active vehicle function or I/O function is operating which inhibits range.



**CAUTION:** The transmission will not shift into range from **N** if a **CHECK TRANS** code is active. If a **CHECK TRANS** code is active, move vehicle to a safe location before turning off the engine.

Conditions which illuminate the **CHECK TRANS** light disable the shift selector. The **SELECT** display is blank and the **MONITOR** display shows the range actually attained. For a detailed explanation, refer to the **CHECK TRANS LIGHT** paragraph in the **DRIVING TIPS** section.

Once **D** (Drive) is attained, the transmission will shift into the lowest forward range programmed for the **D** (Drive) position, usually first-range.

**Display Mode/Diagnostic Button.** The **DISPLAY MODE/DIAGNOSTIC** button allows access to fluid level information and diagnostic code information.

- Move the shift lever to **N** and apply the parking brakes.
- Press the **DISPLAY MODE/DIAGNOSTIC (DMD)** button once to access oil level information (if an OLS is installed).
- Press the **DMD** again to access the diagnostic code information.
- Press the **MODE** button to view subsequent code positions d2 through d5.
- To exit the diagnostic code mode, move the shift lever to another position.

## **PUSHBUTTON SHIFT SELECTOR.**

**General Description.** The pushbutton shift selector (refer to Figure 7) has the following components:

- **R** (Reverse)—Press this button to select Reverse
- **N** (Neutral)—Press this button to select Neutral
- **D** (Drive)—Press this button to select Drive. The highest forward range available will appear in the digital display window. The transmission will start out in the lowest available forward range and advance automatically to the highest range.
- **↑ (Up) Arrow**—Press the **↑ (Up) Arrow** when in **D** (Drive) to request the next higher range. Continually pressing the **↑ (Up) Arrow** will request the highest range available.
- **↓ (Down) Arrow**—Press the **↓ (Down) Arrow** when in **D** (Drive) to request the next lower range. Continually pressing the **↓ (Down) Arrow** will request the lowest range available.

- **MODE Button**—The **MODE** button can allow the driver to enable a secondary shift schedule, PTO enable, or other special functions that have been programmed into the TCM at the request of the OEM. For example, a vehicle OEM may have provided a secondary shift schedule for improved fuel economy. The name of the special function (ECONOMY) appears on the MODE ID label adjacent to the **MODE** button. Pressing the **MODE** button activates the ECONOMY shift schedule and illuminates the MODE INDICATOR LED. When the Diagnostic Display Mode has been entered, the **MODE** button is used to view and toggle through diagnostic code information. The code displayed is active if the MODE INDICATOR LED is illuminated.

**Digital Display.** Allison 4<sup>th</sup> Generation Controls contain two digital displays, SELECT and MONITOR. During normal operation, if **D** (Drive) is selected, the SELECT display shows the highest forward range attainable for the shift schedule in use. The MONITOR display shows the lowest available forward range.

Limited operation is indicated by the digital display as follows:

- All digital display segments are illuminated during initialization. If after 10 seconds communication is not established with the TCM, both digital displays show  $\backslash$  (cateyes).
- When both digital displays show  $\backslash$  (cateyes), a selector-related fault code has been logged.
- When the SELECT display shows **R** or **D** has been requested and the display is flashing the selected range, then the selected range has not been attained due to an inhibit function. Refer to RANGE SHIFTS AND INHIBITS in the DRIVING TIPS section.
- Inhibited range, shown by a flashing SELECT digital display, is not an indication that there is a transmission condition or problem, nor does it indicate that a DTC has set. An inhibit means there is a vehicle or engine condition that won't allow range selection or direction change such as:
  - Too high idle speed in **N** to allow **R** or **D**
  - Too high a throttle signal in **N** to allow **R** or **D**
  - Too high of an output speed in **N** to allow **R** or **D**
  - An active vehicle function or I/O function is operating which inhibits range.



**CAUTION:** The transmission will not shift into range from **N** if a **CHECK TRANS** code is active. If a **CHECK TRANS** code is active, move vehicle to a safe location before turning off the engine.

Conditions which illuminate the **CHECK TRANS** light disable the shift selector. The SELECT display is blank and the MONITOR display shows the range actually attained. For a detailed explanation, refer to the CHECK TRANS LIGHT paragraph in the DRIVING TIPS section.

Once **D** (Drive) is attained, the transmission will shift into the lowest forward range programmed for the **D** (Drive) position, usually first-range.

---



**NOTE:** The oil level sensor (OLS) is standard on 3000 and 4000 Product Families transmissions (optional on the 4700 OFS/SP, 4800 SP, not available on 3700 SP). Fluid level information is displayed by simultaneously pressing the **↑ (Up) Arrow** and **↓ (Down) Arrow** buttons. Simultaneously press both buttons again to obtain diagnostic code information.

---

To display stored codes, do the following:

- Select **N** and apply the parking brakes.
- Simultaneously press the **↑ (Up) Arrow** and **↓ (Down) Arrow** buttons once to access oil level information (if an OLS is installed).
- Simultaneously press the **↑ (Up) Arrow** and **↓ (Down) Arrow** buttons again to access diagnostic codes.
- Press the **MODE** button to display the next code. Repeat for code positions d3 through d5.
- Press **N** (Neutral) to exit the diagnostic code mode.

Refer to the CARE AND MAINTENANCE section, FLUID LEVEL CHECK USING PUSHBUTTON OR LEVER SHIFT SELECTOR, for more information about fluid level data. Refer to the DRIVING TIPS section, DIAGNOSTIC CODES DISPLAY PROCEDURE, for more information about diagnostic codes and display procedure.

## DESCRIPTION OF AVAILABLE ALLISON 4<sup>TH</sup> GENERATION MY09 PROGNOSTICS SHIFT SELECTOR TYPES

---



**NOTE:** This section is for Allison 4<sup>th</sup> Generation Model Year 2009 (MY09) Prognostics **ENABLED**. Refer to the previous section for MY09 Prognostics **DISABLED** and seven-speed transmissions which don't have Prognostics.

---

### LEVER SHIFT SELECTOR.

**General Description.** The Allison lever shift selector (refer to Figure 8) is an electromechanical control. Typical lever positions are:

- **R** (Reverse)
- **N** (Neutral)
- **D** (Drive)
- Some number of lower forward range positions

Allison transmissions can be programmed to have up to six (seven for 4700 OFS/SP and 4800 SP) forward ranges. Shift selector positions should agree with the programming of the TCM.

The lever shift selector includes the following:

- **HOLD OVERRIDE** button
- **MODE** button
- **DISPLAY MODE/DIAGNOSTIC** button
- SELECT and MONITOR digital displays and service icon

**Hold Override Button.** The lever shift selector has three locked positions to prevent accidentally selecting **R** (Reverse), **N** (Neutral), or **D** (Drive). Select **R** (Reverse), **N** (Neutral), or **D** (Drive) by pressing the **HOLD OVERRIDE** button and moving the lever to the desired position. Once **D** (Drive) is selected, lower forward range positions may be selected without pressing the **HOLD OVERRIDE** button.

**MODE Button.** The **MODE** button can allow the driver to enable a secondary shift schedule, PTO enable, or other special functions that have been programmed into the TCM unit at the request of the OEM. For example, a vehicle OEM may have provided a secondary shift schedule for improved fuel economy. The name of the special function (**ECONOMY**) appears on the MODE ID label adjacent to the **MODE** button. Pressing the **MODE** button activates the **ECONOMY** shift schedule and illuminates the MODE INDICATOR LED.

When the Diagnostic Display Mode has been entered, the **MODE** button is used to view and toggle through diagnostic code information. The code displayed is active if the MODE INDICATOR LED is illuminated.

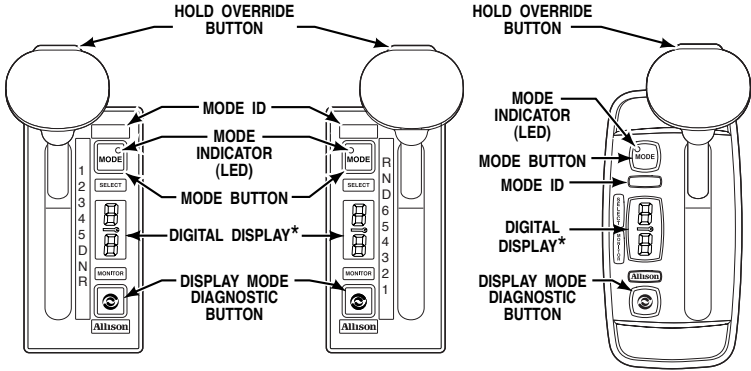

**SIX-SPEED,  
LEFT-HAND  
LEVER SELECTOR**

**SEVEN-SPEED,  
RIGHT-HAND  
LEVER SELECTOR**

**CONTOURED  
BEZEL**

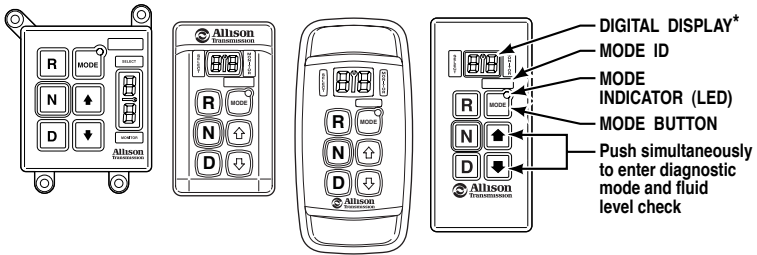

**PUSHBUTTON SELECTORS**

**\*NOTE:** The first number displayed in the digital display is the highest forward range available and second number is range attained in selected position.

Visually confirm that the range selected was attained. If display is flashing, shift is inhibited.

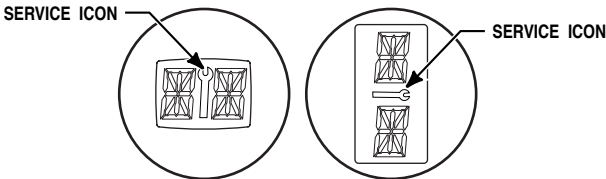

Location of service icon on vertical and horizontal digital display

V11058.00.00

**Figure 8. Typical Allison 4<sup>th</sup> Generation MY09 Prognostics Shift Selectors**



**NOTE:** Visually observe the digital display whenever the lever is moved. **N** should appear in the digital display if **N** is selected.

**Digital Display.** Allison 4<sup>th</sup> Generation MY09 Prognostics shift selectors contain two digital displays (SELECT and MONITOR) and a service icon (open-end wrench) located between the two displays. During normal operation, if **D** (Drive) is selected, the SELECT display shows the highest forward range attainable for the shift schedule in use. The MONITOR display shows the lowest available forward range.

Limited operation is indicated by the digital display as follows:

- All digital display segments are illuminated during initialization. If after 10 seconds communication is not established with the TCM, both digital displays show  $\backslash$  (cateries).
- When both digital displays show  $\backslash$  (cateries), a selector-related fault code has been logged.
- If the service icon is flashing or fully illuminated, a Prognostics function is indicated. Refer to PROGNOSTICS FUNCTIONALITY FOR MY09 in the CARE AND MAINTENANCE section of this manual to determine which function is indicated.
- When the SELECT display shows **R** or **D** has been requested and the display is flashing the selected range, then the selected range has not been achieved due to an inhibit function. Refer to RANGE SHIFTS AND INHIBITS in the DRIVING TIPS section.
- An inhibited range, shown by a flashing SELECT digital display, is not an indication that there is a transmission condition or problem, nor does it indicate that a DTC has set. An inhibit means there is a vehicle or engine condition that won't allow range selection attainment or direction change such as:
  - Too high idle speed in **N** to allow **R** or **D**
  - Too high a throttle signal in **N** to allow **R** or **D**
  - Too high of an output speed in **N** to allow **R** or **D**
  - An active vehicle function or I/O function is operating which inhibits range.



**CAUTION:** The transmission will not shift into range from **N** if a **CHECK TRANS** code is active. If a **CHECK TRANS** code is active, move vehicle to a safe location before turning off the engine.

Conditions which illuminate the **CHECK TRANS** light disable the shift selector. The **SELECT** display is blank and the **MONITOR** display shows the range actually attained. For a detailed explanation, refer to the **CHECK TRANS LIGHT** paragraph in the **DRIVING TIPS** section.

Once **D** (Drive) is attained, the transmission will shift into the lowest forward range programmed for the **D** (Drive) position, usually first-range.

**Display Mode/Diagnostic Button.** The **DISPLAY MODE/DIAGNOSTIC** button allows access to fluid level information, Prognostics information, and diagnostic code information.

- Move the shift lever to **N** and apply the parking brake.
- Press the **DISPLAY MODE/DIAGNOSTIC (DMD)** button once to access oil level information.
- Press the **DMD** again to access the Oil Life Monitor.
- Press the **DMD** again to access the Filter Life Monitor.
- Press the **DMD** again to access the Transmission Health Monitor.
- Press the **DMD** again to access the diagnostic code information.
- Press the **MODE** button to view subsequent code positions d2 through d5.
- To exit the diagnostic code mode, move the shift lever to another position.

#### **PUSHBUTTON SHIFT SELECTOR.**

**General Description.** The pushbutton shift selector (refer to Figure 8) has the following components:

- **R (Reverse)**—Press this button to select Reverse
- **N (Neutral)**—Press this button to select Neutral
- **D (Drive)**—Press this button to select Drive. The highest forward range available will appear in the displayed in the **SELECT** digital display and the **MONITOR** digital display will show the lowest available forward range. The transmission will start out in the lowest available forward range and advance automatically to the highest range.
- **↑ (Up) Arrow**—Press the **↑ (Up) Arrow** when in **D (Drive)** to request the next higher range. Continually pressing the **↑ (Up) Arrow** will request the highest range available.
- **↓ (Down) Arrow**—Press the **↓ (Down) Arrow** when in **D (Drive)** to request the next lower range. Continually pressing the **↓ (Down) Arrow** will request the lowest range available.
- **MODE Button**—The **MODE** button can allow the driver to enable a secondary shift schedule, PTO enable, or other special functions that have been programmed into the TCM at the request of the OEM. For example, a vehicle OEM may have provided a secondary shift schedule for improved fuel economy. The name of the special function (**ECONOMY**) appears on the **MODE ID** label adjacent to the **MODE** button. Pressing the **MODE** button activates the **ECONOMY** shift schedule and illuminates the **MODE INDICATOR LED**. When the Diagnostic Display Mode has been entered,

the **MODE** button is used to view and toggle through diagnostic code information. The code displayed is active if the MODE INDICATOR LED is illuminated.

- SELECT and MONITOR digital display and service icon

**Digital Display.** Allison 4<sup>th</sup> Generation MY09 Prognostics contain two digital displays (SELECT and MONITOR) and a service icon (open-end wrench) located between the two displays. During normal operation, if **D** (Drive) is selected, the SELECT display shows the highest forward range attainable for the shift schedule in use. The MONITOR display shows the lowest available forward range.

Limited operation is indicated by the digital displays as follows:

- All display segments are illuminated during initialization. If after 10 seconds communication is not established with the TCM, both displays show  $\backslash$  (catelyes).
- When both displays show a  $\backslash$  (catelye), a selector-related fault code has been logged.
- If the service icon is flashing or fully illuminated, a Prognostics function is indicated. Refer to PROGNOSTICS FUNCTIONALITY FOR MY09 in the CARE AND MAINTENANCE section of this manual to determine which function is indicated.
- When the SELECT display shows **R** or **D** has been requested and the display is flashing the selected range, then the selected range has not been attained due to an inhibit function. Refer to RANGE SHIFTS AND INHIBITS in the DRIVING TIPS section.
- Inhibited range, shown by a flashing SELECT digital display, is not an indication that there is a transmission condition or problem, nor does it indicate that a DTC has set. An inhibit means there is a vehicle or engine condition that won't allow range selection or direction change such as:
  - Too high idle speed in **N** to allow **R** or **D**
  - Too high a throttle signal in **N** to allow **R** or **D**
  - Too high of an output speed in **N** to allow **R** or **D**
  - An active vehicle function or I/O function is operating which inhibits range.



**CAUTION:** The transmission will not shift into range from **N** if a **CHECK TRANS** code is active. If a **CHECK TRANS** code is active, move vehicle to a safe location before turning off the engine.

Conditions which illuminate the **CHECK TRANS** light disable the shift selector. The SELECT display is blank and the MONITOR display shows the range actually attained. For a detailed explanation, refer to the CHECK TRANS LIGHT paragraph in the DRIVING TIPS section.



Once **D** (Drive) is attained, the transmission will shift into the lowest forward range programmed for the **D** (Drive) position, usually first-range.



To display stored codes, do the following:

- Select **N** and apply the parking brakes.
- Simultaneously press the **↑ (Up) Arrow** and **↓ (Down) Arrow** buttons once to access oil level information (if an OLS is installed).
- Simultaneously press the **↑ (Up) Arrow** and **↓ (Down) Arrow** buttons again to access the Oil Life Monitor.
- Simultaneously press the **↑ (Up) Arrow** and **↓ (Down) Arrow** buttons again to access the Filter Life Monitor.
- Simultaneously press the **↑ (Up) Arrow** and **↓ (Down) Arrow** buttons again to access the Transmission Health Monitor.
- Simultaneously press the **↑ (Up) Arrow** and **↓ (Down) Arrow** buttons again to access the diagnostic codes.
- Press the **MODE** button to display the next code. Repeat for code positions d3 through d5.
- Press **N** (Neutral) to exit the diagnostic code mode.





Refer to the CARE AND MAINTENANCE section, FLUID LEVEL CHECK USING PUSHBUTTON OR LEVER SHIFT SELECTOR, for more information about fluid level data. Refer to the DRIVING TIPS section, DIAGNOSTIC CODES DISPLAY PROCEDURE, for more information about diagnostic codes and display procedure.

# RANGE SELECTION



## PUSHBUTTON AND LEVER SHIFT SELECTORS WITH DIGITAL DISPLAY

Description of Available Ranges (refer to Figure 1 through Figure 3)		
R E V E R S E		<p><b>WARNING:</b> If you leave the vehicle and the engine is running, the vehicle can move unexpectedly and you or others could be injured. If you must leave the engine running, do not leave the vehicle until you have completed all of the following procedures:</p> <ol style="list-style-type: none"> <li>1. Put the transmission in <b>N</b> (Neutral).</li> <li>2. Be sure the engine is at low idle (500–800 rpm).</li> <li>3. Apply the parking brakes and emergency brake and make sure they are properly engaged.</li> <li>4. Chock the wheels and take any other steps necessary to keep the vehicle from moving.</li> </ol>
		<p><b>WARNING:</b> <b>R</b> (Reverse) may not be attained due to an active inhibitor. Always apply the service brakes when selecting <b>R</b> (Reverse) to prevent unexpected vehicle movement and because a service brake inhibit may be present. When “<b>R</b>” is flashing, it indicates the shift to <b>R</b> (Reverse) is inhibited. Determine if diagnostic codes are active if <b>R</b> (Reverse) is not attained. Refer to DOWNSHIFT AND DIRECTION CHANGE INHIBITOR FEATURE in the DRIVING TIPS section.</p>
		<p><b>CAUTION:</b> Do not idle in <b>R</b> (Reverse) for more than five minutes. Extended idling in <b>R</b> (Reverse) can cause transmission overheating and damage. Always select <b>N</b> (Neutral) whenever time at idle exceeds five minutes.</p>

## PUSHBUTTON AND LEVER SHIFT SELECTORS WITH DIGITAL DISPLAY *(cont'd)*

Description of Available Ranges (refer to Figure 1 through Figure 3)		
R E V E R S E		<p><b>NOTE:</b> Visually observe the digital display window whenever a button is pushed or the lever is moved to be sure the range selected is shown (i.e., if the <b>N</b> (Neutral) button is pressed, “<b>N</b>” should appear in the digital display). A flashing display indicates the range selected was not attained due to an active inhibit.</p>
	<b>R</b>	<p>Completely stop the vehicle and let the engine return to idle before shifting from a forward range to <b>R</b> (Reverse) or from <b>R</b> (Reverse) to a forward range. The digital display will display “<b>R</b>” when <b>R</b> (Reverse) is selected.</p>
N E U T R A L		<p><b>WARNING:</b> When starting the engine, make sure the service brakes are applied. Failure to apply the service brakes can result in unexpected vehicle movement.</p>
		<p><b>WARNING:</b> Vehicle service brakes, parking brake, or emergency brake must be applied whenever <b>N</b> (Neutral) is selected to prevent unexpected vehicle movement. Selecting <b>N</b> (Neutral) does not apply vehicle brakes, unless an auxiliary system to apply the parking brake is installed (refer to the Operator’s Manual for the vehicle).</p>
		<p><b>WARNING:</b> If you let the vehicle coast in <b>N</b> (Neutral), there is no engine braking and you could lose control. Coasting can also cause severe transmission damage. To help avoid injury and property damage, do not allow the vehicle to coast in <b>N</b> (Neutral).</p>

**PUSHBUTTON AND LEVER SHIFT SELECTORS  
WITH DIGITAL DISPLAY (cont'd)**

<b>Description of Available Ranges (refer to Figure 1 through Figure 3)</b>		
N E U T R A L	<b>N</b>	Use <b>N</b> (Neutral) when starting the engine, to check vehicle accessories, and for extended periods of engine idle operation (longer than five minutes). For vehicles equipped with the pushbutton selector, <b>N</b> (Neutral) is selected by the TCM/ECU during start-up. For vehicles equipped with the lever selector, the vehicle will not start unless <b>N</b> (Neutral) has been selected. If the vehicle starts in any range other than <b>N</b> (Neutral), seek service immediately. <b>N</b> (Neutral) is also used during stationary operation of the power takeoff (if the vehicle is equipped with a PTO). The digital display will show “ <b>N</b> ” when <b>N</b> (Neutral) is selected. Always select <b>N</b> (Neutral) before turning off the vehicle engine.
D R I V E		<b>WARNING:</b> <b>D</b> (Drive) may not be attained due to an active inhibitor. Always apply the service brakes when selecting <b>D</b> (Drive) to prevent unexpected vehicle movement and because a service inhibit may be present. When “ <b>D</b> ” is flashing, it indicates the shift to <b>D</b> (Drive) is inhibited. Determine if diagnostic codes are active if <b>D</b> (Drive) is not attained. Refer to DOWNSHIFT AND DIRECTION CHANGE INHIBITOR FEATURE in the DRIVING TIPS section.
		<b>CAUTION:</b> Do not idle in <b>D</b> (Drive) for more than five minutes. Extended idling in <b>D</b> (Drive) may cause transmission overheating and damage. Always select <b>N</b> (Neutral) if time at idle exceeds five minutes.
		<b>NOTE:</b> Turn off the vehicle HIGH IDLE switch, if present, before shifting from <b>N</b> (Neutral) to <b>D</b> (Drive) or <b>R</b> (Reverse). <b>D</b> (Drive) or <b>R</b> (Reverse) will not be attained unless the shift is made with the engine at idle. Also, be aware of other interlocks that would prevent attaining <b>D</b> (Drive) or <b>R</b> (Reverse). Example: “service brakes not applied” (service brake interlock present).

**PUSHBUTTON AND LEVER SHIFT SELECTORS  
WITH DIGITAL DISPLAY (cont'd)**

<b>Description of Available Ranges (refer to Figure 1 through Figure 3)</b>		
D R I V E	<b>D</b>	The transmission will initially attain first range when <b>D</b> (Drive) is selected (except for those units programmed to start in second-range). As vehicle speed increases, the transmission will upshift automatically through each range. As the vehicle or equipment slows down, the transmission will automatically downshift to the correct range. The digital display will show the highest range available in <b>D</b> (Drive).

## PUSHBUTTON AND LEVER SHIFT SELECTORS WITH DIGITAL DISPLAY (*cont'd*)

Description of Available Ranges (refer to Figure 1 through Figure 3)		
		<p><b>WARNING:</b> The transmission incorporates a hold feature to prohibit upshifting above the range selected during normal driving. For downhill operation, select a lower transmission range. If the engine governed speed is exceeded in the held range, however, the transmission will upshift to the next higher range to prevent engine damage. To avoid injury and/or property damage due to loss of vehicle control, use the vehicle brakes to prevent exceeding engine governed speed in the held range.</p>
M A N U A L  S E L E C T	7+ 6* 5* 4* 3 2	<p>Lower ranges provide greater engine braking for going down grades (the lower the range, the greater the braking effect). Occasionally, it may be desirable to restrict automatic shifting to a lower range because of:</p> <ul style="list-style-type: none"> <li>• Road conditions.</li> <li>• Load.</li> <li>• Traffic conditions.</li> <li>• Etc.</li> </ul> <p>The pushbutton shift selector arrow buttons access individual forward ranges. Push the ↑ (Up) or ↓ (Down) arrow for the desired range. The digital display shows the range chosen. Even though a lower range is selected, the <b>transmission may not downshift</b> until vehicle speed is reduced (this prevents excessive engine speed in the lower range).</p>
	<b>1</b>	<p>First-range provides the vehicle with its maximum driving torque and engine braking effect. Use first-range when:</p> <ul style="list-style-type: none"> <li>• Pulling through mud and deep snow.</li> <li>• Maneuvering in tight spaces.</li> <li>• Driving up or down steep grades.</li> </ul> <p>For vehicles equipped with the pushbutton selector, push the ↓ (Down) arrow until first-range appears in the select window.</p>

**PUSHBUTTON AND LEVER SHIFT SELECTORS  
WITH DIGITAL DISPLAY (cont'd)**

<b>Description of Available Ranges (refer to Figure 1 through Figure 3)</b>		
		<p><b>Transfer Case Differential</b>—The 3700 SP transmission is equipped with a torque proportioning differential to provide appropriate torque and speed to the front and rear axles in difficult traction situations. The operator can request this function by activating a separate switch or the MODE button on the shift selector (check your operator’s manual). To deactivate the function, the switch is turned off or is deactivated automatically by the ECU at a programmed speed.</p>
<p>+ Only available in 4700/4800 SP and OFS, and 3700 SP. * Actual ranges available depend on programming by vehicle manufacturer.</p>		

---

# DRIVING TIPS

---

## CHECK TRANS LIGHT

The electronic control system is programmed to inform the operator of a problem with the transmission system and automatically take action to protect the operator, vehicle, and transmission. When the Electronic Control Unit (ECU) or the Transmission Control Module (TCM) logs a DTC, the TCM/ECU:

- Restricts shifting.
- Illuminates the **CHECK TRANS** light on the instrument panel.
- Registers a diagnostic code.



**NOTE:** Some diagnostic codes may be logged without the TCM/ECU activating the **CHECK TRANS** light. Your Allison Transmission authorized service outlet should be consulted whenever there is a transmission-related concern. They have the equipment to access and troubleshoot diagnostic codes.

---

The **CHECK TRANS** light will illuminate each time the engine is started, then turn off after a few seconds. This momentary lighting is to show that the status light circuits are working properly. If the **CHECK TRANS** light does not illuminate during ignition, or if the light remains on after ignition, have the transmission inspected at the earliest opportunity by an Allison Transmission authorized service outlet.

Continued illumination of the **CHECK TRANS** light during vehicle operation (other than start-up) indicates that the TCM/ECU has signaled a diagnostic code. The single digit shift selector display will show the actual range attained and the transmission will not respond to shift selector requests. The dual digit shift selector will blank the range selected and show the range attained with a **CHECK TRANS** light.

Indications from the shift selector are provided to inform the operator the transmission is not performing as designed and is operating with reduced capabilities. Before turning off the ignition, the transmission may be operated for a short time in the attained range in order to get the vehicle to a safe location for



service assistance. Service should be performed immediately in order to minimize the potential for damage to the transmission.

When the **CHECK TRANS** light is illuminated and the ignition switch is turned off, the transmission will remain in **N** (Neutral) until the condition causing the **CHECK TRANS** light is corrected.

Generally, while the **CHECK TRANS** light is on, upshifts and downshifts will be restricted and **direction changes will not occur**. Lever and pushbutton shift selectors **do not respond** to any operator shift requests while the **CHECK TRANS** light is illuminated. The lockup clutch is disengaged when transmission shifting is restricted.

## DIAGNOSTIC CODES OVERVIEW

Diagnostic codes are numerical indications relating to a malfunction in transmission or vehicle operation. These codes are logged in the TCM/ECU memory with the most severe or most recent code listed first. A maximum of five codes (numbered d1–d5) may be listed in memory at one time. As codes are added, the oldest non-active code is dropped from the list. If all codes are active, the code with the lowest priority that is not included on the severity list is dropped from the list.

Diagnostic codes and code information may be accessed through the pushbutton and lever shift selectors or the Allison DOC™ For PC–Service Tool.

The TCM/ECU separately stores the active and historical (non-active) codes. An active code is any code that is current in the TCM/ECU decision-making process.

Historical codes (not active) are codes that are retained in the TCM/ECU memory and will not necessarily affect the TCM/ECU decision-making process. Historical codes are useful in determining if a DTC:

- Is isolated.
- Is intermittent.
- Results from a previous malfunction.

The TCM/ECU may automatically delete a code from memory if it has not recurred for a period of time.

If the **MODE INDICATOR (LED)** is illuminated, the displayed code is active. If the **MODE INDICATOR** (refer to through Figure 8) is not illuminated, the displayed code is not active. An illuminated **MODE INDICATOR** during normal operation signifies secondary mode operation.

# ALLISON 4<sup>TH</sup> GENERATION CONTROLS DIAGNOSTIC CODE DISPLAY PROCEDURE



**NOTE:** Use this section for Allison 4<sup>th</sup> Generation Controls, MY09 Prognostics **DISABLED**, and seven-speed transmissions which don't have MY09 Prognostics.

Diagnostic codes can be read and cleared by either of the following methods:

- Allison DOC™ For PC–Service Tool. For specific instructions on how to use the Allison DOC™ For PC–Service Tool, refer to Allison Transmission publication GN3433EN, User Guide.
- Pushbutton or lever shift selectors.

**Pushbutton Shift Selector.** *To begin the Diagnostic Process:*

1. Bring the vehicle to a stop at a safe location.
2. Shift to **N** (Neutral).
3. Apply the parking brake.

*To Display Stored Codes (refer to Figure 7):*

1. If an OLS is present, simultaneously press the **↑ (Up)** and **↓ (Down)** **arrow** buttons twice to display the first code.
2. When the diagnostic code mode is entered, the first code (d1) is displayed as follows:

Example–code P0722

Displays as **d 1, P, 0 7, 2 2** (each item appears for about one second)

Allison 4<sup>th</sup> Generation shift selectors have two digital displays, **SELECT** and **MONITOR**. Each item is displayed for about one second. The display cycles continuously until the next code list position is accessed by pressing the **MODE** button. There is a 2 minute timer that will timeout if no buttons are pressed causing **N N** to display instead of the diagnostic code.

The following example shows how the DTC P0722 is displayed on the pushbutton shift selector.

DIGITAL DISPLAY	
SELECT	MONITOR
d	1
	P
0	7
2	2

- d 1 (code list position); the position which a code occupies in the code list. Positions are displayed as “d1” through “d5”.
  - P0722 (DTC); the diagnostic trouble code number referring to the general condition or area of fault detected by the TCM.
3. Press the **MODE** button to view the next code; repeat for subsequent codes.



**NOTE:** Be sure to record all codes displayed before they are cleared. This is essential for troubleshooting.

---

*To Clear Active Indicators and Inactive Codes then Resume Vehicle Operation:*

- To clear active indicators such as the **CHECK TRANS** light, press and hold the **MODE** button for approximately three seconds until the MODE INDICATOR LED flashes. Release the **MODE** button and active indicators will not be illuminated.
- To clear inactive codes, press and hold the **MODE** button for 10 seconds. Some codes are self-clearing and others require ignition cycles to clear.



**NOTE:** If the condition that caused the code is still present, the code will again become active.

---

Begin operating as normal. Have the transmission inspected at the earliest opportunity by an Allison Transmission distributor or dealer.

**Lever Shift Selector.** *To Begin the Diagnostic Process:*

1. Bring the vehicle to a stop at a safe location.
2. Shift to N (Neutral).
3. Apply the parking brake.

*To Display Stored Codes (refer to Figure 7):*

1. If an OLS is present, press the **DISPLAY MODE/DIAGNOSTIC (DMD)** button twice to display the first code.
2. Refer to the Pushbutton Shift Selector for an explanation of code displays.
3. Press the **MODE** button to view the next code; repeat for subsequent codes.



**NOTE:** Be sure to record all codes displayed before they are cleared. This is essential for troubleshooting.

---

*To Clear Active Indicators and Inactive Codes then Resume Vehicle Operation:*

1. To clear active indicators such as the **CHECK TRANS** light, press and hold the **MODE** button for approximately three seconds until the **MODE INDICATOR (LED)** flashes. Release the **MODE** button and active indicators will not be illuminated.
2. To clear inactive codes, press and hold the **MODE** button for 10 seconds.
3. Depending on the code(s), active indicators can be cleared:
  - On successful power down
  - Manually
  - Self clearing.



**NOTE:** If the condition that caused the code is still present, the code will again become active.

---

Begin operating as normal. Have the transmission inspected at the earliest opportunity by an Allison Transmission distributor or dealer.

## **ALLISON 4<sup>TH</sup> GENERATION MY09 PROGNOSTICS DIAGNOSTIC CODE DISPLAY PROCEDURE**

---



**NOTE:** Use this section for Allison 4<sup>th</sup> Generation MY09 Prognostics **ENABLED**. Refer to the previous section for Allison 4<sup>th</sup> Generation MY09 Prognostics **DISABLED**, and seven-speed transmissions which don't have MY09 Prognostics.

---

Diagnostic codes can be read and cleared by either of the following methods:

- Allison DOC™ For PC–Service Tool. For specific instructions on how to use the Allison DOC™ For PC–Service Tool, refer to Allison Transmission publication GN3433EN, User Guide.
- Pushbutton or lever shift selectors.

**Pushbutton Shift Selector.** *To begin the Diagnostic Process:*

1. Bring the vehicle to a stop at a safe location.
2. Shift to **N** (Neutral).
3. Apply the parking brake.

*To Display Stored Codes (refer to Figure 8):*

1. Simultaneously press the **↑ (Up)** and **↓ (Down) arrow** buttons to display oil level information.
2. Simultaneously press the **↑ (Up)** and **↓ (Down) arrow** buttons again to display Oil Life Monitor.

3. Simultaneously press the ↑ (**Up**) and ↓ (**Down**) **arrow** buttons again to display Filter Life Monitor.
4. Simultaneously press the ↑ (**Up**) and ↓ (**Down**) **arrow** buttons again to display Transmission Health Monitor.
5. Simultaneously press the ↑ (**Up**) and ↓ (**Down**) **arrow** buttons again to display diagnostic code mode.
6. When the diagnostic code mode is entered, the first code (d1) is displayed as follows:

Example—code P0722

Displays as **d 1, P, 0 7, 2 2** (each item appears for about one second)

The Allison 4<sup>th</sup> Generation shift selectors have two digital displays, SELECT and MONITOR. Each item is displayed for about one second. The display cycles continuously until the next code list position is accessed by pressing the **MODE** button. The following example shows how the DTC P0722 is displayed on the pushbutton shift selector.

<b>DIGITAL DISPLAY</b>	
<b>SELECT</b>	<b>MONITOR</b>
d	1
	P
0	7
2	2

- d 1 (code list position); the position which a code occupies in the code list. Positions are displayed as “d1” through “d5”.
  - P0722 (DTC); the diagnostic trouble code number referring to the general condition or area of fault detected by the TCM.
7. Press the **MODE** button to view the next code; repeat for subsequent codes.



**NOTE:** Be sure to record all codes displayed before they are cleared. This is essential for troubleshooting.

---

*To Clear Active Indicators and Inactive Codes then Resume Vehicle Operation:*

- To clear active indicators such as the **CHECK TRANS** light, press and hold the **MODE** button for approximately three seconds until the **MODE INDICATOR LED** flashes. Release the **MODE** button and active indicators will not be illuminated.
- To clear inactive codes, press and hold the **MODE** button for 10 seconds. Some codes are self-clearing and others require ignition cycles to clear.



**NOTE:** If the condition that caused the code is still present, the code will again become active.

---

Begin operating as normal. Have the transmission inspected at the earliest opportunity by an Allison Transmission distributor or dealer.

**Lever Shift Selector.** *To Begin the Diagnostic Process:*

1. Bring the vehicle to a stop at a safe location.
2. Shift to **N** (Neutral).
3. Apply the parking brake.

*To Display Stored Codes:*

1. Press the **DISPLAY MODE/DIAGNOSTIC (DMD)** button once to display the oil level information.
2. Press the **DMD** button again to display the Oil Life Monitor.
3. Press the **DMD** button again to display the Filter Life Monitor.
4. Press the **DMD** button again to display the Transmission Health Monitor.
5. Press the **DMD** button again to access the diagnostic code mode.
6. Press the **MODE** button to view the next code; repeat for subsequent codes.



**NOTE:** Be sure to record all codes displayed before they are cleared. This is essential for troubleshooting.

---

*To Clear Active Indicators and Inactive Codes then Resume Vehicle Operation:*

1. To clear active indicators such as the **CHECK TRANS** light, press and hold the **MODE** button for approximately three seconds until the **MODE INDICATOR (LED)** flashes. Release the **MODE** button and active indicators will not be illuminated.
2. To clear inactive codes, press and hold the **MODE** button for 10 seconds. Some codes are self-clearing and others require ignition cycles to clear.



**NOTE:** If the condition that caused the code is still present, the code will again become active.

---

Begin operating as normal. Have the transmission inspected at the earliest opportunity by an Allison Transmission distributor or dealer.

## ACCELERATOR CONTROL



**WARNING:** To help avoid unexpected vehicle movement that might cause death, serious injury, or property damage, always have your foot on the brake, the throttle released, and the engine at idle before making a **N** (Neutral) to **D** (Drive); **N** (Neutral) to **R** (Reverse); **D** (Drive) to **R** (Reverse); or **R** (Reverse) to **D** (Drive) selection.

The position of the accelerator pedal influences when automatic shifting occurs. An electronic throttle position signal tells the TCM/ECU how much the operator has depressed the pedal. When the pedal is fully depressed, upshifts will occur automatically at higher engine speeds. A partially depressed position of the pedal will cause upshifts to occur at lower engine speeds. Excessive throttle position affects directional changes—shifts from **N** (Neutral) to **D** (Drive) or **R** (Reverse).

---

## RANGE SHIFTS AND INHIBITS



**NOTE:** Turn off the vehicle **HIGH IDLE** switch, if present, before shifting from **N** (Neutral) to **D** (Drive) or **R** (Reverse). The shift from **N** (Neutral) to **D** (Drive) or **R** (Reverse) is inhibited when engine speed is above idle.

---

**Range Shifts.** There is no speed limitation on upshifting, but there is a limitation on downshifting and for shifts that cause a direction change such as **D** (Drive)-to-**R** (Reverse) or **R** (Reverse)-to-**D** (Drive).

Manual range downshifts will not occur until a calibration output speed (preset) is reached. When a range downshift is manually selected and the transmission output speed is above the calibration speed, the transmission will stay in the range it was in even though a lower range was requested. Apply the vehicle service brakes or a retarding device to reduce the transmission output speed to the calibration speed and then the shift to the lower range will occur.

**Inhibits.** Directional shifts, **D** (Drive)-to-**R** (Reverse), **R** (Reverse)-to-**D** (Drive) and **N** (Neutral)-to-range, will not occur if selected when throttle position, engine speed, or transmission output speed is above the calibration limit for a calibration time period. The current calibration time period for engine speed is 0.5 seconds and for throttle position and output speed is three seconds. Range inhibits latch after the time period and the driver will have to re-select the desired range.

Shifts from **N** (Neutral)-to-**D** (Drive) or **N** (Neutral)-to-**R** (Reverse) are also inhibited when the TCM/ECU has been programmed (by input/output function) to detect that auxiliary equipment is in operation and the shift should not be allowed.

When directional change shifts and **N** (Neutral)-to-range shifts are inhibited, the TCM/ECU will put the transmission in **N** (Neutral) and the digital display will flash an **R** for Reverse inhibit or the range selected digit for a **D** for Drive inhibit. When range inhibits latch because the timer expires, the driver must re-select a range.

For a pushbutton selector, press the desired pushbutton again.

For a lever selector, move the lever to **N** (Neutral) and then to the desired range.

When a direction change shift is requested and engine throttle, engine speed, and transmission output speed drop below the calibration value during the calibration time interval, the shift to **D** (Drive) or **R** (Reverse) will occur.

## USING THE ENGINE TO SLOW THE VEHICLE



**WARNING:** To help avoid loss of control, use a combination of downshifting, braking, and other retarding devices. Downshifting to a lower transmission range increases engine braking and can help you maintain control. The transmission has a feature to prevent automatic upshifting above the lower range selected. However, during downhill operation, if engine governed speed is exceeded in the lower range, the transmission will upshift to the next higher range to prevent engine damage. This will reduce engine braking and could cause a loss of control. Apply the vehicle brakes or other retarding device to prevent exceeding engine governed speed in the lower range selected.

Engine braking provides good speed control for going down grades. When the vehicle is heavily loaded, or the grade is steep, it may be desirable to preselect a lower range before reaching the grade. If engine-governed speed is exceeded, the transmission will upshift automatically to the next range.

To use engine braking, select the next lower range. If the vehicle is exceeding the maximum speed for this range, use the service brakes and/or retarder to slow the vehicle. When a lower speed is reached, the TCM/ECU will automatically downshift the transmission.



## USING THE HYDRAULIC RETARDER



**WARNING:** DO NOT USE THE RETARDER DURING INCLEMENT WEATHER OR WHEN ROAD SURFACES ARE SLIPPERY.

Use of the hydraulic retarder during inclement weather or when road surfaces are slippery could result in death, serious injury, or property damage. On vehicles which have a primary retarder control based upon closed throttle position, brake pedal position, or brake apply pressure, always manually disable the retarder controls during inclement weather or slippery road conditions, using the OEM provided retarder enable switch if present.

If the transmission retarder does not apply, death, serious injury, or property damage may occur. Operator should be prepared to apply vehicle brakes or other retarder device if the transmission retarder does not apply.

If the transmission retarder does not function, death, serious injury, or property damage may occur. Be sure to test for proper retarder function periodically. If a retarder is present but is not detected by “autodetect”, the retarder will not function. Whenever the retarder does not apply, seek service help immediately.

Regardless of the type of Allison retarder controls on your vehicle, the following safety features are common to each configuration:

- The retarder can be disabled when inclement weather or slippery road conditions are present.
- Vehicle brake lights should always be on when the retarder is applied (periodically verify that they are working).
- Anti-lock brake systems send a signal to the transmission TCM/ECU to indicate that the brake system is activated.



**NOTE:** The retarder is automatically disabled and the lockup clutch is disengaged whenever the vehicle anti-lock brake system (ABS) is active. However, in case the ABS system malfunctions, it is recommended that the retarder enable switch, if present, be disabled.

A hydraulic retarder is available on all of the models covered in this manual. The retarder is activated and controlled in various ways. The control depends upon the vehicle type and particular duty cycle. Both manual and automatic controls are available. Automatic controls are applied by the TCM/ECU. In Allison 4<sup>th</sup> Generation Control systems, the TCM may also activate or limit retarder operation in response to torque speed control or electronic retarder control messages

received on the vehicle's J1939 Data Link. Some types of controls and the amount of retarder application are shown in the Types of Retarder Control table that follows.

The presence of a retarder must be “autodetected” as part of Allison 4<sup>th</sup> Generation Controls control system.



**NOTE:** If your transmission has a retarder but it is not functioning, it may not have been “autodetected” during vehicle manufacture. Consult the nearest Allison Transmission service outlet to have “autodetect” reset or the retarder enabled using the Allison DOC™ For PC–Service Tool.

---



**NOTE:** When reduced retarder performance is observed, be sure the transmission fluid level is within the operating band on the dipstick (refer to Figure 11). Low fluid level is a common cause for retarder performance complaints.

---



**NOTE:** The retarder requires about two seconds to reach full capacity. Be sure to anticipate this delay when using the retarder. Anticipation will prevent unnecessary service brake applications during non-emergency stops.

---

## Types of Retarder Control

Type	Description	Amount of Application
Manual	Separate apply pedal	Zero to Full apply
	Hand lever *	Six levels based on lever position
Automatic	Auto “Full On” *	“Full On” when closed throttle sensed
Brake Pressure Apply**	Single pressure switch	Off or “Full On” (based on brake pressure)
	Three pressure switches	$\frac{1}{3}$ , $\frac{2}{3}$ , or “Full On” (based on brake pressure)
Pedal Position **	Special brake pedal	$\frac{1}{3}$ , $\frac{2}{3}$ , or “Full On” (based on pedal position)
J1939 Data Link	Digital message from engine controller	Zero to Full Apply
Combinations of the above systems **	Auto “half-on” plus pressure switch *	Half capacity at closed throttle or “Full On” with brake pressure
	Auto “ $\frac{1}{3}$ on” plus two pressure switches *	$\frac{1}{3}$ , capacity at closed throttle or $\frac{2}{3}$ and “Full On” with brake pressure
	Hand lever plus pressure switch *	6 levels of modulation with lever, or “Full On” with brake pressure
	Foot pedal plus pressure switch	Full modulation with separate pedal, or “Full On” with brake pressure
	Hand lever plus interface for special pedal *	6 levels of modulation with lever, or 3 levels of modulation based on pedal position
* These control systems may apply the retarder at high speed on grades when the vehicle has road speed limiting and the retarder is enabled.		
** For retarder apply systems integrated with the service brake system, the retarder is most effective when applied with light brake pedal pressure for 1–2 seconds to allow the retarder to fully charge. Added pedal pressure can be applied when more aggressive braking is desired.		



**NOTE:** When the transmission fluid or engine water temperature (engine water temperature is an OEM option) exceeds programmed limits, retarder capacity is automatically gradually reduced to minimize or avoid possible system overheating.

Contact your vehicle manufacturer to understand how the retarder controls have been integrated into your vehicle.



**CAUTION:** Observe the following cautions when driving a vehicle equipped with a retarder:

- THE RETARDER WORKS ONLY WHEN THE ENGINE IS AT CLOSED THROTTLE.
- OBSERVE TRANSMISSION AND ENGINE TEMPERATURE LIMITS AT ALL TIMES. Select the lowest possible transmission range to increase the cooling system capacity and total retardation available.
- In the event of OVERHEATING, DECREASE THE USE OF THE RETARDER; USE THE SERVICE BRAKES TO SLOW THE VEHICLE.
- OBSERVE THE RETARDER/SUMP “OVERTEMP” LIGHT to be sure it responds properly to retarder temperature.



**NOTE:** The transmission retarder is configured as either a low, medium, or high capacity retarder. Retarder capacity configuration is determined by the vehicle OEM. Allison Transmission requires vehicle OEM approval before a service outlet increases the retarder capacity at customer request. This vehicle qualification is to make sure existing vehicle drivelines, differentials, axles, and cooling system are designed for the additional retarder torque generated in a higher capacity retarder configuration. Allison 4<sup>th</sup> Generation retarder requires only a TCM re-calibration with the OEM approval for a higher capacity retarder. Cost incurred to modify retarder capacity is the responsibility of the customer.



**NOTE:** Allison 4<sup>th</sup> Generation retarder activation, response, and driver requested retarder amount are characteristically similar but not identical. Refer to the Types of Retarder Control Table in this section to see how retarder modulation request (RMR) can be changed if desired to increase or decrease retarder percentage apply. These controls are also OEM determined and installed. Cost incurred to modify a RMR is the responsibility of the customer.



**NOTE:** Transmission fluid level must be set correctly for highest retarder effectiveness. As much as 2 liters (2 quarts) too high or too low can reduce retarder effectiveness and increase transmission temperature.

## RANGE PRESELECTION

---



**NOTE:** Preselecting during normal operation may result in reduced fuel economy.

---

Range preselection means selecting a lower range to match driving conditions encountered or expect to be encountered. Learning to take advantage of preselected shifts will give you better control on slick or icy roads and on downgrades.

Downshifting to a lower range increases engine braking. The selection of a lower range often prevents cycling between that range and the next higher range on a series of short up-and-down hills.

## COLD WEATHER STARTS

All transmissions are programmed to restrict full operation until specific fluid temperatures are reached. Refer to the following table for temperature restrictions.

**Minimum Fluid Operating Temperatures**

<b>Sump Fluid Temperature</b>	<b>CHECK TRANS Light</b>	<b>Operation</b>
-32°C (-25°F) to -7°C (19°F)	OFF	Neutral, Reverse, Second
-7°C (19°F)	OFF	Full operation in all ranges



**NOTE:** When sump temperature is below 10°C (50°F) and transmission fluid is **not DEXRON®**, **TES 389**, or **TES 295**, follow these procedures when making directional shift changes:

- To shift from forward to reverse, select **N** (Neutral) and then **R** (Reverse).
- To shift from reverse to forward, select **N** (Neutral) and then **D** (Drive) or other forward range.

Failure to follow these procedures may cause illumination of the **CHECK TRANS** light and the transmission will be restricted to **N** (Neutral).

---

Transmission operation at cold ambient temperatures may require preheating or the use of a lower viscosity transmission fluid. Refer to **MANUAL FLUID CHECK PROCEDURE** in the **CARE AND MAINTENANCE** section.

## DRIVING ON SNOW OR ICE



**WARNING:** Using the retarder on wet or slippery roads may cause loss of traction on the drive wheels—your vehicle may slide out of control. To help avoid injury or property damage, turn the retarder enable to OFF when driving on wet or slippery roads.



**NOTE:** The retarder is automatically disabled whenever the vehicle ABS is active. However, in case the anti-lock brake system (ABS) malfunctions, it is recommended that the retarder enable switch, if present, be disabled.

If possible, reduce vehicle speed and select a lower range before losing traction. Select the range that will not exceed the speed expected to be maintained.

Accelerate or decelerate very gradually to prevent the loss of traction. It is very important to decelerate gradually when a lower range is selected. It is important that you reach the selected lower range before attempting to accelerate. This will avoid an unexpected downshift during acceleration.

## ROCKING OUT



**WARNING:** To help avoid injury or property damage caused by sudden movement of the vehicle, do not make shifts from **N** (Neutral) to **D** (Drive) or **R** (Reverse) when the throttle is open. The vehicle may lurch forward or rearward and the transmission can be damaged. Avoid this condition by making shifts from **N** (Neutral) to a forward range or **R** (Reverse) only when the throttle is closed and the service brakes are applied.



**CAUTION:** DO NOT make **N** (Neutral) to **D** (Drive) or directional shift changes when the engine rpm is above idle. Also, if the wheels are stuck and not turning, do not apply full power for more than 10 seconds in either **D** (Drive) or **R** (Reverse). Full power for more than 10 seconds under these conditions will cause the transmission to overheat. If the transmission overheats, shift to **N** (Neutral) and operate the engine at 1200–1500 rpm until it cools (2–3 minutes).

If the vehicle is stuck in deep sand, snow, or mud, it may be possible to rock it out using the following procedure:

1. Shift to **D** (Drive) and apply steady, light throttle (**never full throttle**).

2. When the vehicle has rocked forward as far as it will go, apply and hold the vehicle service brakes.
3. When engine has returned to idle, select **R** (Reverse).
4. Release the brakes and apply a steady, light throttle allowing the vehicle to rock in **R** (Reverse) as far as it will go.
5. Again, apply and hold the service brakes and allow the engine to return to idle.

This procedure may be repeated in **D** (Drive) and **R** (Reverse) if each directional shift continues to move the vehicle a greater distance. **Never** make **N** (Neutral)-to-**D** (Drive) or directional shift changes when the engine rpm is above idle.

## HIGH FLUID TEMPERATURE

The transmission is considered to be overheated when any of the following temperatures are exceeded:

Sump fluid	121°C (250°F)
Fluid to cooler	149°C (300°F)
Retarder out fluid	165°C (330°F)

If the transmission overheats during normal operations, be sure the fluid level is correct in the transmission. Refer to the fluid level check procedures described in the CARE AND MAINTENANCE section.



**CAUTION:** The engine should never be operated for more than 10 seconds at full throttle with the transmission in range and the output stalled. Prolonged operation of this type will cause the transmission fluid temperature to become excessively high and will cause severe overheating damage to the transmission.

If the engine temperature gauge indicates a high temperature, the transmission is probably overheated. Stop the vehicle and check the cooling system. If it appears to be functioning properly, run the engine at 1200–1500 rpm with the transmission in **N** (Neutral). This should reduce the transmission and engine temperatures to normal operating levels in 2 or 3 minutes. If temperatures do not decrease, reduce the engine rpm.

If the engine temperature indicates a high temperature, an engine or radiator problem is indicated. If high temperature in either the engine or transmission persists, stop the engine and have the overheating condition investigated by maintenance personnel.

## PARKING BRAKE



**WARNING:** If you leave the vehicle and the engine is running, the vehicle can move unexpectedly and you or others could be injured. If you must leave the engine running, **DO NOT LEAVE** the vehicle until you have completed all of the following procedures:

- Put the transmission in **N** (Neutral).
- Be sure the engine is at low idle (500–800 rpm).
- Apply the parking brake and emergency brake and make sure they are properly engaged.
- Chock the wheels and take other steps necessary to keep the vehicle from moving.

The parking brake is only intended to secure an unattended vehicle with the engine ignition **OFF**. Always maintain the vehicle parking brake system according to the manufacturer's specifications. The parking brake may not have sufficient capacity to restrain a vehicle with the engine running and the transmission in a forward or reverse range. When the vehicle is unattended and the engine is in operation, the transmission **must be in N** (Neutral) with the **brakes fully applied** and the **wheels chocked**.

## TOWING OR PUSHING



**CAUTION:** Failure to lift the driving wheels off the road, disconnect the driveline, or remove the axle shafts before pushing or towing can cause serious transmission damage.

The engine cannot be started by pushing or towing. Before pushing or towing a vehicle do one of the following:

- Disconnect the driveline.
- Lift the drive wheels off the road.
- Remove the axle shafts from the drive wheels.

An auxiliary air supply will usually be required to actuate the vehicle brake system.

When the axle shafts are removed, be sure to cover the wheel openings to prevent loss of lubricant and entry of dust and dirt.

## TURNING OFF THE VEHICLE

Always select **N** (Neutral) before turning off the vehicle engine.



## PRIMARY/SECONDARY SHIFT SCHEDULES

The points at which shifts occur depend upon predetermined speeds and other operating conditions. A transmission “shift calibration” includes several sets of shift points which may be used according to current or anticipated operating conditions. Some shift schedules may be inhibited as a result of operating conditions, such as engine or transmission fluid temperature. Shift schedules may be changed using the **MODE** button (some applications may use a dash-mounted switch)—which is typically associated with a change in anticipated vehicle operation.

The TCM/ECU includes the capacity for two separate and distinct shift calibrations (customer-selectable), one for use in “Primary Mode” of operation and one in “Secondary Mode.”

- **Primary**—This shift schedule is typically used for all normal vehicle operations.
- **Secondary**—This is an alternate shift schedule that the TCM/ECU uses upon request. Not all vehicles will be equipped with a secondary shift schedule. The request can be interlocked with a vehicle component, or be operator-controlled using the **MODE** button.

Your vehicle may have a dash-mounted light that illuminates when the secondary mode is active.

## CRUISE CONTROL OPERATION

Operating an Allison transmission-equipped vehicle on cruise control may cause the transmission to shift cycle if the cruise control speed setting is set too close to a scheduled shift point. One of the following actions may eliminate shift cycling:

- Select the secondary shift schedule by pushing the **MODE** button (refer to through Figure 8) on the shift selector.
- Select a lower range by pushing the ↓ (**Down**) **Arrow** or moving the lever on the shift selector.
- Change the cruise control setting away from the shift point.

Some vehicles equipped with an engine brake will have the engine brake controlled by the TCM/ECU. This is done so the transmission will automatically select a lower range when the engine brake is turned on and the throttle is near idle position.

Operating a vehicle on cruise control with the engine brake turned on and controlled by the transmission TCM/ECU, may cause an unwanted application of the engine brake when the cruise control decelerates for downhill grades. Eliminate this condition by turning off the engine brake while operating the vehicle on cruise control.

## OPERATING DOWN STEEP GRADES (REAR-DISCHARGE MIXER)



**CAUTION:** With this transmission, the service brakes must be used when backing a loaded rear-discharge mixer down a grade. But too much brake application, particularly on an unpaved surface, can lock the front brakes and reduce steering control. A crash could then occur. To help prevent injury or property damage:

1. Drive forward down the grade and then exit by backing up the grade when you can do so.
2. If equipped, use the trailer brake when backing the mixer down a grade. Do not use the trailer brake as a parking brake once the vehicle is at the bottom of the grade.
3. If a trailer brake is not available, back the mixer down the grade by modulating the service brakes to control and maintain a safe, steady vehicle speed. Avoid abrupt stops and starts.

---

# POWER TAKEOFF OPERATION

---

## ENGINE-DRIVEN POWER TAKEOFF (PTO)



**CAUTION:** Do not exceed the engagement and operational speed limits imposed on the driven equipment during the operation of the PTO. Exceeding the speed limits produces high hydraulic pressure in the PTO that can damage the PTO components. Consult the vehicle manufacturer's literature for these speed limits.

If a PTO is present, it will normally be mounted on either the left or right side of the 3000 Product Family transmission. On the 4000 Product Family transmission, the PTO will be located on the left side or on the top of the transmission. The PTO drive gear is engine-driven and therefore provides direct engine power. The PTO can be operated when the vehicle is either moving or stopped.

The PTO gear is in constant mesh with the drive gear in the converter housing. However, the PTO may either be constant-drive (output always powered) or clutch-driven. When the PTO is clutch-driven, the clutch is part of the PTO, not the transmission. A clutch-driven PTO is powered only when the PTO clutch is engaged.

All Allison transmission-equipped vehicles with PTO enable have engagement and operational speed limits programmed into the TCM/ECU to help protect PTO equipment. Be sure the limits for PTO engagement speed and operational speed are not exceeded. Consult the vehicle manufacturer's literature for these speed limits. Some speed limits have default values which are programmed out of the operating range and will need to be set for your particular PTO duty cycle. Consult your vehicle manufacturer to see if your transmission has been programmed and what operational limits have been established.

When the programmed engagement speed is exceeded, the PTO will not engage. The PTO engagement must be retried after the speed has been reduced. When operational speeds (either engine or transmission output) are exceeded, the PTO will deactivate and the PTO engagement process must be repeated.

---

# CARE AND MAINTENANCE

---

## PERIODIC INSPECTIONS

Careful attention to the fluid level and connections for the electronic and hydraulic circuits is very important.

For easier inspection, the transmission should be kept clean. Make regular periodic inspections for:

- Loose bolts.
- Leaking fluid around fittings, lines, and transmission openings.
- The condition of the electrical harnesses.
- The presence of transmission fluid in the engine cooling system and transmission fluid for the presence of coolant, which would indicate a faulty oil cooler.
- A clean and dirt and debris free breather (refer to Figure 3 through Figure 6) to make sure it is clean and free from dirt or debris.

Report any abnormal condition to service management.

## PREVENT MAJOR PROBLEMS

You can help keep minor problems from becoming major problems by contacting an Allison Transmission distributor or dealer when one of these conditions occur:

- Shifting feels odd.
- Transmission leaks fluid.
- Unusual transmission-related sounds (changes in sound caused by normal engine thermostatic fan cycling, while climbing a long grade with a heavy load, have been mistaken for transmission-related sounds).
- **CHECK TRANS** light comes on frequently.

## IMPORTANCE OF PROPER FLUID LEVEL

It is important that the proper fluid level be maintained at all times because the transmission fluid cools, lubricates, and transmits hydraulic power. If the fluid level is too low, the converter and clutches do not receive an adequate supply of fluid. If fluid level is too high, the fluid can aerate. Aerated fluid can cause the transmission to shift erratically or overheat.

An oil level sensor (OLS) is standard on Allison 4th Generation 3000 and 4000 Product Families transmissions through six-speed, and optional on 4700 OFS/SP, 4800 SP, not available on 3700 SP. The OLS allows the operator to obtain an indication of the fluid level from the full-function shift selector. However, no OLS information is available unless the OLS is “autodetected” by the TCM/ECU.

Frequently look for the presence of oil level diagnostics if the transmission is known to contain an OLS. If an OLS is not detected during a fixed number of engine starts, the TCM/ECU concludes that no OLS is present. If an OLS is known to be present, but has not been detected, then troubleshooting of the OLS circuit is required. After the OLS circuit is repaired, reset “autodetect” or manually select the OLS function using Allison DOC™ For PC–Service Tool. For detailed troubleshooting procedures refer to the Troubleshooting Manual. Refer to the SERVICE LITERATURE section for specific publication numbers.



**NOTE:** To correctly determine the transmission fluid level using the dipstick, the transmission fluid must be at operating temperature. The oil level sensor method of determining the fluid level compensates for transmission fluid temperature between 60°C–104°C (140°F–220°F). Any temperature below 60°C (140°F) or above 104°C (220°F) will result in an **Invalid for Display** condition.

---

## ALLISON 4<sup>TH</sup> GENERATION MY09 PROGNOSTICS DISABLED AND SEVEN SPEED TRANSMISSION FLUID LEVEL CHECK USING ALLISON SHIFT SELECTORS

The transmission **must be** equipped with the OLS to be able to read fluid level information. The oil level sensor (OLS) is standard on 3000 and 4000 Product Families transmissions (optional on the 4700 OFS/SP, 4800 SP, not available on 3700 SP).



**NOTE:** Allison 4<sup>th</sup> Generation pushbutton and lever shift selectors have two digital displays, SELECT and MONITOR. The fluid level information is displayed two characters at a time.

---

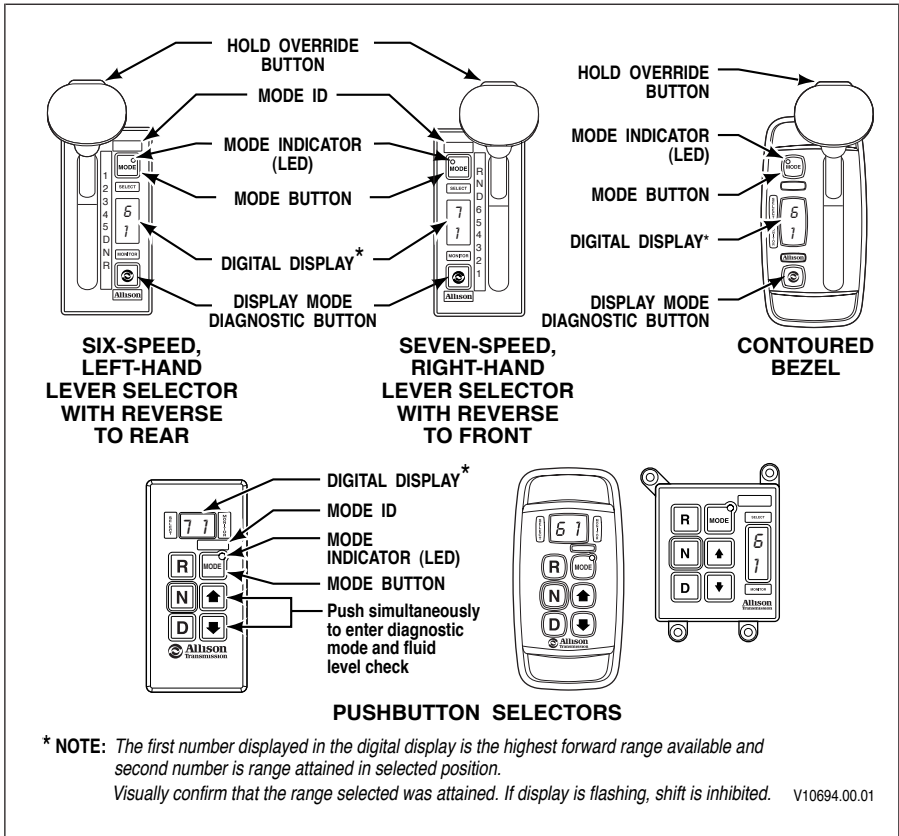

**Figure 9. Typical Allison 4<sup>th</sup> Generation Shift Selectors**

To access oil level information (refer to Figure 9):

1. Park the vehicle on a level surface, shift to **N** (Neutral), and apply the parking brake.
2. **Pushbutton shift selector**—simultaneously press the **↑ (Up)** and **↓ (Down) Arrow** buttons once.
3. **Lever shift selector**—press the **DISPLAY MODE/DIAGNOSTIC** button once.

The fluid level check may be delayed until the following conditions are met:

- The fluid temperature is above 60°C (140°F) and below 104°C (220°F).
- The transmission is in **N** (Neutral).
- The engine is at idle.
- The transmission output shaft is stopped.

- The vehicle has been stationary for approximately two minutes to allow the fluid to settle.

A delayed fluid level check is indicated by a “-” in each of the digital displays (SELECT and MONITOR) followed by a numerical countdown. The countdown, from 8 to 1, indicates the time remaining in the two minute waiting period.

The following is an explanation of what will appear in the SELECT and MONITOR digital displays.

- **Correct Fluid Level**

SELECT	MONITOR	Description
“o”	“L”	Represents Fluid (oil) Level Check Mode
“o”	“K”	Fluid level is within the correct fluid level zone



**NOTE:** The sensor display and the dipstick may not agree exactly because the OLS compensates for fluid temperature.

- **Low Fluid Level**

SELECT	MONITOR	Description
“o”	“L”	Represents Fluid (oil) Level Check Mode
“L”	“o”	Represents Low Oil Level
“0”	“2”	The number of quarts the transmission is low

- **High Fluid Level**

SELECT	MONITOR	Description
“o”	“L”	Represents Fluid (oil) Level Check Mode
“H”	“I”	Represents High Oil Level
“0”	“1”	The number 1 indicates 1 quart of fluid above the full transmission level

• Invalid for Display

SELECT	MONITOR	Description
“o”	“L”	Represents Fluid (oil) Level Check Mode
“_”	“_”	The dashes are followed by a numerical display which is a fault code that indicates conditions are not proper to receive the fluid level information or there is a system malfunction. The fault codes that may be encountered are shown in Table 2, Fluid Level Fault Codes.

**Table 2. Fluid Level Fault Codes**

Display (Previous)	Display (MY08, Cal/Sfw or current)	Cause of Code
oL, - -,0X	oL, - -,0X	Settling time too short*
oL, - -,50	oL, - -,EL	Engine speed (rpm) too low
oL, - -,59	oL, - -,EH	Engine speed (rpm) too high
oL, - -,65	oL, - -,SN	Neutral must be selected
oL, - -,70	oL, - -,TL	Sump fluid temperature too low
oL, - -,79	oL, - -,TH	Sump fluid temperature too high
oL, - -,89	oL, - -,SH	Output shaft rotation
oL, - -,95	oL, - -,FL	Sensor failure**
<p>* A number between 8 and 1 that flashes during the countdown period.</p> <p>** Speed sensor, throttle position sensor, temperature sensor, or oil level sensor failure should be reported to a distributor or dealer in your area (consult the telephone directory for an Allison Transmission distributor or dealer).</p>		



**CAUTION:** A low or high fluid level can cause overheating and irregular shift patterns. Incorrect fluid level can damage the transmission.



**NOTE:** To exit the fluid level display mode, press any range button on the pushbutton shift selector, or press the **DISPLAY MODE/ DIAGNOSTIC** button once on the lever shift selector.



## PROGNOSTICS FUNCTIONALITY FOR MODEL YEAR 2009

---



**NOTE: Prognostics enabled requires the use of Allison Approved TES 295 transmission fluid and Allison High Capacity Filters.** If any other fluids or filters are used, Prognostics **must be DISABLED**. Prognostics information will not be accurate with any other fluid or filters and could result in missed maintenance activities resulting in transmission damage.

---

The three Prognostics functions are enabled or disabled as a group and cannot be enabled or disabled individually. The OEM is the one who advises Allison whether the Allison Prognostics feature should be available and functional in the calibration installed in the TCM. The OEM may specify to enable the feature and also default them to run (turn them on), enable the feature but keep them turned off (not run by default but could be turned on with the Allison DOC™ re-programming tool) or finally disabled in the calibration and cannot be turned on by Allison DOC™ re-programming tool. The OEM may also specify whether Prognostics may be reset by the Allison shift selector, J1939 message, or only with the use of the Allison DOC™ For PC–Service Tool.

Refer to Table 4A and Table 4B for instructions to access Prognostics Functions through the shift selectors.

**Oil Life Monitor (OM).** Oil life is calculated based on hours of engine and transmission operation. Miles will be approximated from the hours and calibrated information. The number of shifts per mile will determine the duty cycle of the transmission and the oil life limits will be based on the observed duty cycle. Hours will be accumulated when the engine is running including when the vehicle is stationary for PTO operation or for extended idle time.

Oil life is calculated on the following:

- Operating hours
- Output revolutions
- Shift density
- Retarder accumulator applies.

Calendar based fluid requirements (refer to FLUID AND FILTER CHANGE INTERVAL RECOMMENDATIONS at the end of this section) still apply because Oil Life Monitor cannot measure time while ignition power is OFF. If the OM has not indicated the need for a fluid change before 60 months (five years) have passed, it will be necessary to change the fluid and filters per calendar requirements and reset the system.

Oil life Monitor displays the percentage of life remaining as follows:

- Allison Transmission shift selector display—fluid life remaining will be displayed from 99 percent down to 00 percent.
- Allison DOC™ For PC–Service Tool—fluid life remaining will be displayed from 100 percent down to –100 percent.
- When maintenance is required, the service icon will come on steady at “key on” and remain on for about two minutes after **D** (Drive) has been selected. If transmission maintenance continues to be unattended, the **CHECK TRANS** light will illuminate and diagnostic code P0897, Transmission Fluid at Limit, will be set. This indicates that the remaining fluid life has reached 1 percent.

If reset is not restricted to the service tool only, a J1939 message can be sent to reset. Also, an Allison shift selector reset may be accomplished by one of the following methods:

- Display the Oil Life Monitor information and press and hold the **MODE** button for ten seconds.
- With the ignition ON and the engine OFF, shift between **N-D-N-D-N-R-N** to reset the value displayed to 99.

The manual reset method is shown in the Allison DOC™ For PC–Service Tool in the Prognostics Customer Modified Constant (CMC) Group and can be set to restrict reset to the service tool only. If resets are restricted to the service tool only, they may be made by using the specific Action Request in the Allison DOC™ For PC–Service Tool.

The service indicator icon will illuminate briefly following a reset to acknowledge that the reset was successful. The Allison DOC™ For PC–Service Tool may be used to review reset history and the mileage recorded at the time of reset.

**Filter Life Monitor (FM).** Filter Life Monitor is used to indicate when the filters (main and lube) require changing (3-, 4-, 5-, and 6-speed transmissions only). The Prognostics pressure switch is activated when fluid exiting the main filter drops below a pre-determined pressure. Both the main and lube filters **must be** changed when the service icon indicates the main filter should be changed. The differential pressure limit is verified for a period of time to be sure there is no false indication of the need to change filters.

The Filter Life Monitor displays the filter condition as follows:

- Allison Transmission shift selector either OK or LO
- Allison DOC™ For PC–Service Tool indicates the Filter Life Monitor Expired as YES or NO.

When a filter change is indicated, diagnostic code P088A, Transmission Filter At/Over Limit, is set and the service icon will flash at “key on” and continue to flash for approximately two minutes after **D** (Drive) has been selected, then go out. If the filters are not changed and the indicator reset, the **CHECK TRANS**

light will illuminate and diagnostic code P088B, Transmission Filter At/Over Limit, will be set to indicate a deteriorated filter condition.

When new filters have been installed, the Filter Life Monitor will automatically reset after a period of time without a signal from the Prognostic pressure switch. A manual reset method is shown in the Allison DOC™ For PC–Service Tool in the Prognostics CMC Group. The Prognostics CMC can be set to restrict reset to the Allison DOC™ For PC–Service Tool. If reset is not restricted, a J1939 message may be sent to reset or shift selector resets may be performed by one of the following methods:

- With the ignition ON and the engine OFF, shift between **N-R-N-R-N-D-N** to reset the value displayed on the shift selector to OK.
- Display the Filter Life Monitor information and press and hold the **MODE** button of an Allison shift selector for ten seconds.

If resets are restricted to the service tool only, they may be made by using the specific Action Request in the Allison DOC™ For PC–Service Tool.

**Transmission Health Monitor (TM).** The Transmission Health function monitors the clutch system based on adaptive control parameter change over time. Clutch life is monitored for C1, C2, C3, C4, and C5 clutches only.

Transmission Health displays as follows:

- Allison shift selector—OK until the remaining life of one or more of the clutches indicates an issue to display LO. The specific clutch(es) for which the shift selector reads LO cannot be identified using the shift selector display.
- Allison DOC™ For PC–Service Tool displays clutch condition as OK or NOT OK for each clutch, C1 through C5.
- NA is displayed until transmission is adapted.

When one or more clutches indicate the need for replacement, at “key on” the service icon on the Allison shift selector will come on steady and remain on steady at all times during vehicle operation. The display will show “LO”. This is caused by the change in calculated clutch free running clearance exceeding the wear-out state. Additional troubleshooting is required to be sure clutches require replacing.

Failure to perform maintenance/repair after a number of warnings will result in the **CHECK TRANS** light illuminating and diagnostic code P2789, Clutch Adaptive Learning at Limit, being set. Reset will occur automatically when the clutch life recalculates below wear-out state (free running clearances calculate less than service limits). Manual reset is possible only through the correct Action Request in the Allison DOC™ For PC–Service Tool.

The Allison DOC™ For PC–Service Tool will be able to review the amount of transmission operation from the triggering event until service reset.

# ALLISON 4<sup>TH</sup> GENERATION MY09 PROGNOSTICS ENABLED FLUID LEVEL CHECK USING ALLISON SHIFT SELECTORS

---



**NOTE:** Use this section for six-speed transmissions when Prognostics have been **ENABLED**.

---

The transmission **must be** equipped with an OLS to be able to read fluid level information. The oil level sensor (OLS) is standard on 3000 and 4000 Product Families transmissions (optional on the 4700 OFS/SP, 4800 SP, not available on 3700 SP).

---



**NOTE:** Allison 4<sup>th</sup> Generation pushbutton and lever shift selectors have two digital displays, **SELECT** and **MONITOR**. The fluid level information is displayed two characters at a time.

---

To access oil level information (refer to Figure 10):

1. Park the vehicle on a level surface, shift to **N** (Neutral), and apply the parking brake.
2. **Pushbutton shift selector**—simultaneously press the **↑ (Up)** and **↓ (Down) Arrow** buttons once.
3. **Lever shift selector**—press the **DISPLAY MODE/DIAGNOSTIC** button one time.

The fluid level check may be delayed until the following conditions have been met:

- The fluid temperature is above 60°C (140°F) and below 104°C (220°F).
- The transmission is in **N** (Neutral).
- The engine is at idle.
- The transmission output shaft is stopped.
- The vehicle has been stationary for approximately two minutes to allow the fluid to settle.

A delayed fluid level check is indicated by a “—” in each of the digital displays (**SELECT** and **MONITOR**) followed by a numerical countdown. The countdown, from 8 to 1, indicates the time remaining in the two minute waiting period.

A numerical display (alphabetical for MY08) is a fault code and indicates conditions are not proper to receive the fluid level information, or that there is a system malfunction.

- **Correct Fluid Level**—“o, L” is displayed (represents Fluid (Oil) Level Check Mode), followed by “o, K”. The “o, K” display indicates the fluid is

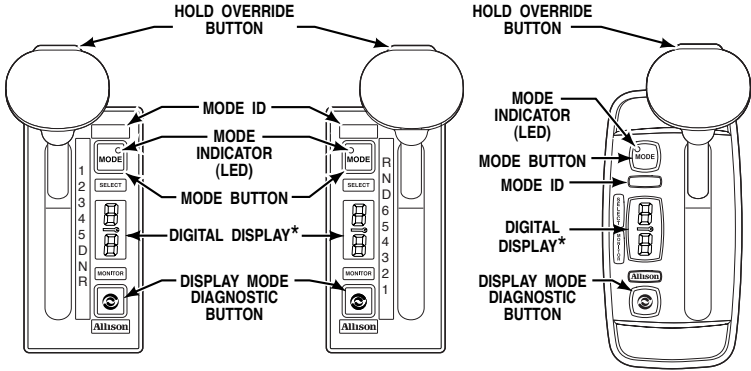

**SIX-SPEED,  
LEFT-HAND  
LEVER SELECTOR**

**SEVEN-SPEED,  
RIGHT-HAND  
LEVER SELECTOR**

**CONTOURED  
BEZEL**

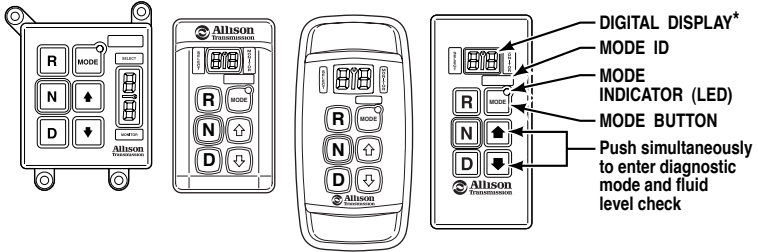

**PUSHBUTTON SELECTORS**

**\*NOTE:** The first number displayed in the digital display is the highest forward range available and second number is range attained in selected position.

Visually confirm that the range selected was attained. If display is flashing, shift is inhibited.

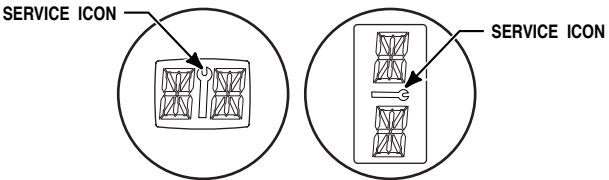

Location of service icon on vertical and horizontal digital display

V11058.00.00

**Figure 10. Typical Allison 4<sup>th</sup> Generation MY09 Prognostics Shift Selectors**

within the correct fluid level zone. The sensor display and the transmission dipstick may not agree exactly because the oil level sensor compensates for fluid temperature.

- **Low Fluid Level**—“o, L” is displayed (represents Fluid (Oil) Level Check Mode) and the number of quarts the transmission fluid is low. Example: “2” indicates 2 additional quarts will bring the fluid level within the middle of the “o, K” zone.
- **High Fluid Level**—“o, L” is displayed (represents Fluid (Oil) Level Check Mode), followed by “HI” (represents High Oil Level) and the number of quarts the transmission is overfilled. Example: “1” indicates 1 quart of fluid above the full transmission level.
- **Invalid For Display**—“o, L” (represents Fluid (Oil) Level Check Mode), followed by “—” and a numerical display (alphabetical for MY08 and newer). The numerical display (alphabetical for MY08 and newer) is a fault code and indicates conditions are not proper to receive the fluid level information, or there is a system malfunction. The fault codes that may be encountered are shown in Table 3, Fluid Level Fault Codes, below.

**Table 3. Fluid Level Fault Codes**

Display (Former)	Display (MY08, Cal/Sfw or newer)	Cause of Code
oL, - -, 0X	oL, - -, 0X	Settling time too short*
oL, - -, 50	oL, - -, EL	Engine speed (rpm) too low
oL, - -, 59	oL, - -, EH	Engine speed (rpm) too high
oL, - -, 65	oL, - -, SN	Neutral must be selected
oL, - -, 70	oL, - -, TL	Sump fluid temperature too low
oL, - -, 79	oL, - -, TH	Sump fluid temperature too high
oL, - -, 89	oL, - -, SH	Output shaft rotation
oL, - -, 95	oL, - -, FL	Sensor failure**
* A number between 8 and 1 that flashes during the countdown period.		
** Speed sensor, throttle position sensor, temperature sensor, or oil level sensor failure should be reported to a distributor or dealer in your area (consult the telephone directory for an Allison Transmission distributor or dealer).		



**CAUTION:** A low or high fluid level can cause overheating and irregular shift patterns. Incorrect fluid level can damage the transmission.

**Allison Shift Selector Service Indicator.** The following tables illustrate how to access each Prognostic function on the Allison pushbutton and lever shift selectors.

**Table 4A. Allison Pushbutton Shift Selectors**

Up/Down Arrow Buttons Pressed Simultaneously	Indications	SELECT	MONITOR
1 <sup>st</sup> press (A delayed fluid level check may occur)	Delayed fluid level check. The dashes are followed by a countdown from 8 down to 1 or a numerical (alphabetical for MY08) fault code that indicates conditions are not proper to receive the fluid level information or there is a system malfunction. The fault codes that may be encountered are shown in the Fluid Level Fault Codes table above.	“_”	“_”
	Fluid level	“o”	“L”
	Fluid level is within the correct fluid level zone	“o”	“K”
	Represents low fluid level	“L”	“o”
	The number of quarts the transmission is low	“0”	“2”
	Represents high fluid level	“H”	“I”
	The number 1 indicates 1 quart of fluid above the full transmission level	“0”	“1”
2 <sup>nd</sup> press	Oil Life Monitor	“O”	“M”
	Oil life remaining will range from 99 percent down to 00	“some number from 9 to 0”	“some number from 9 to 0”
3 <sup>rd</sup> press	Filter Life Monitor	“F”	“M”
	Present life of filters is OK	“O”	“K”
	Present life of filters is low	“L”	“O”
4 <sup>th</sup> press	Transmission Health Monitor	“T”	“M”
	OK until the remaining life of one or more of the clutch(es) wear enough so that the programming changes	“O”	“K”
	One or more of the clutches have worn enough to change the program*	“L”	“O”

**Table 4A. Allison Pushbutton Shift Selectors (cont'd)**

Up/Down Arrow Buttons Pressed Simultaneously	Indications	SELECT	MONITOR
Press and hold <b>MODE</b> button to reset display monitor (Oil Life Monitor and Filter Life Monitor). Clear diagnostic codes when displaying any code.			
* The specific clutch(es) which caused the indication to read “LO” cannot be determined by the shift selector			

**Table 4B. Allison Lever Shift Selectors**

DISPLAY MODE/ DIAGNOSTIC Button (DMD) Pressed	Indications	SELECT	MONITOR
1 <sup>st</sup> <b>DMD</b> button press (A delayed fluid level check may occur)	Delayed fluid level check. The dashes are followed by a countdown from 8 down to 1 or a numerical (alphabetical for MY08) fault code that indicates conditions are not proper to receive the fluid level information or there is a system malfunction. The fault codes that may be encountered are shown in the Fluid Level Fault Codes table above.	“_”	“_”
	Fluid level	“o”	“L”
	Fluid level is within the correct fluid level zone	“o”	“K”
	Represents low fluid level	“L”	“o”
	The number of quarts the transmission is low	“0”	“2”
	Represents high fluid level	“H”	“I”
The number 1 indicates 1 quart of fluid above the full transmission level	“0”	“1”	



**Table 4B. Allison Lever Shift Selectors (cont'd)**

<b>DISPLAY MODE/ DIAGNOSTIC Button (DMD) Pressed</b>	<b>Indications</b>	<b>SELECT</b>	<b>MONITOR</b>
2 <sup>nd</sup> <b>DMD</b> button press	Oil Life Monitor	“O”	“M”
	Present life of fluid is OK	“O”	“K”
	Oil life remaining will range from 99 down to 00	“some number from 9 to 0”	“some number from 9 to 0”
3 <sup>rd</sup> <b>DMD</b> button press	Filter Life Monitor	“F”	“M”
	Present life of filters is OK	“O”	“K”
	Present life of filters is low	“L”	“O”
4 <sup>th</sup> <b>DMD</b> button press	Transmission Health Monitor	“T”	“M”
	OK until the remaining life of one or more of the clutch(es) wear enough so that the programming changes	“O”	“K”
	One or more of the clutches have worn enough to change the program*	“L”	“O”
Press and hold <b>MODE</b> button to reset display monitor (Oil Life Monitor and Filter Life Monitor). Clear diagnostic codes when displaying any code.			
* The specific clutch(es) which caused the indication to read “LO” cannot be determined by the shift selector			

To exit the fluid level display mode, press any range button on the pushbutton shift selector or press the **DISPLAY MODE/DIAGNOSTIC** button on the lever shift selector.

## **FLUID LEVEL CHECK USING DIAGNOSTIC TOOLS**

The transmission must be equipped with the oil level sensor to be able to read fluid level information.

1. Park the vehicle on a level surface and shift to N (Neutral). Apply the parking brake and/or emergency brakes.
2. Obtain fluid level information by following the procedure in the Allison DOC™ For PC User Guide, GN3433EN or by using the OEM-supplied auxiliary display.
3. Fluid level information may be delayed when certain conditions are not met. The Allison DOC™ for PC–Service Tool will display a message

showing which conditions have not been met. The following conditions may delay the fluid level determination procedure:

- Settling time too short
- Engine speed (rpm) too low
- Engine speed (rpm) too high
- **N** (Neutral) must be selected
- Sump fluid temperature too low (below 60°C or 140°F)
- Sump fluid temperature too high (above 104°C or 220°F)
- Output shaft rotation
- Sensor failure

## MANUAL FLUID CHECK PROCEDURE

Refer to Figure 3 through Figure 6 for the location of the fill tube and dipstick.



**WARNING:** If you leave the vehicle and the engine is running, the vehicle can move unexpectedly and you or others could be injured. If you must leave the engine running, do not leave the vehicle until you have completed all of the following procedures:

- Put the transmission in **N** (Neutral)
- Be sure the engine is at low idle (500–800 rpm)
- Apply the parking brakes and emergency brake and make sure they are properly engaged
- Chock the wheels and take any other steps necessary to keep the vehicle from moving.

Clean around the end of the fill tube before removing the dipstick. This will aid in preventing dirt or foreign matter from entering the hydraulic system, which can cause:

- Valves to stick
- Undue wear of transmission parts
- Clogged passages.

Determine that the fluid level is correct using the procedures in **COLD CHECK** and **HOT CHECK**.

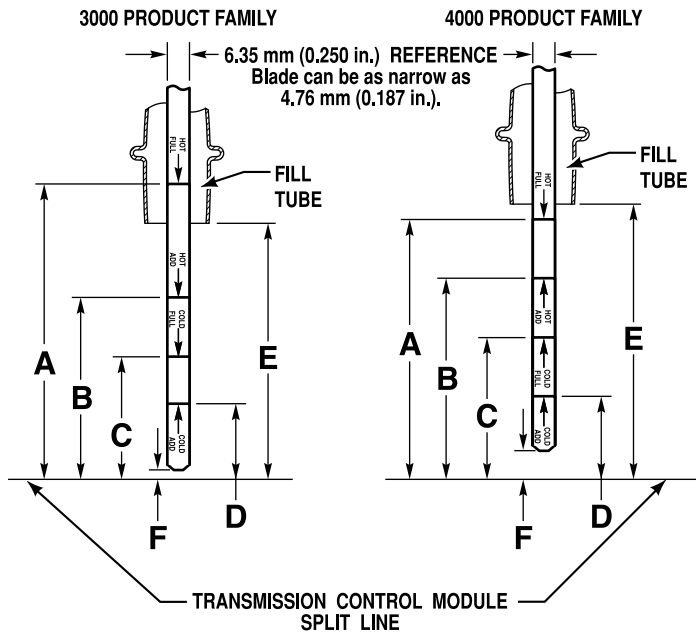

OIL SUMP	TRANSMISSION/SUMP DESCRIPTION	DIMENSION A	DIMENSION B	DIMENSION C	DIMENSION D	DIMENSION E	DIMENSION F**
2.00 in. and 4.00 in.****	4000 PRODUCT FAMILY	106.7 mm (4.20 in.)	76.2 mm (3.00 in.)	66.0 mm (2.60 in.)	*	132.6 mm (5.22 in.)	13.8 mm (0.54 in.)
2.00 in.***	3000 PRODUCT FAMILY	101.6 mm (4.00 in.)	73.7 mm (2.90 in.)	50.8 mm (2.00 in.)	*	86.6 mm (3.41 in.)	5.9 mm (0.23 in.)
4.00 in. and 7.00 in.***	3000 PRODUCT FAMILY	101.6 mm (4.00 in.)	63.5 mm (2.50 in.)	45.7 mm (1.80 in.)	*	86.6 mm (3.41 in.)	5.9 mm (0.23 in.)

**NOTE:** Calibrate level marking locations with respect to transmission control module split line and fill tube.

Scale none.

\*Dimension determined by installation.

\*\*Reference dimension only. Actual dimension to be determined by installation.

\*\*\*Reference drawing AS66-60.

\*\*\*\*Reference drawing AS67-60.

V07301.02.00

**Figure 11. Standard 3000 and 4000 Product Families Transmission Dipstick Markings**

## COLD CHECK

The COLD CHECK determines if the transmission has enough fluid to be operated safely until a HOT CHECK can be made.



**NOTE:** The correct fluid level **cannot be determined** unless the transmission is in a level position.



**CAUTION:** DO NOT start the engine until the presence of sufficient transmission fluid has been confirmed. Remove the transmission fluid dipstick and be sure the static fluid level is near the HOT FULL mark.



**CAUTION:** The fluid level rises as fluid temperature rises. DO NOT fill the transmission above the COLD CHECK band if the transmission fluid is below normal operating temperature. During operation an overfull transmission can become overheated, leading to transmission damage.

A COLD CHECK may be made after initial start-up and the presence of transmission fluid has been confirmed—the sump fluid temperature is then typically 16°–49°C (60°–120°F). To perform a COLD CHECK, do the following:

1. Move the vehicle to a level surface, put the transmission in **N** (Neutral), and set the parking brake.
2. With the engine idling (500–800 rpm), shift to **D** (Drive) and then to **R** (Reverse) to clear air from the hydraulic circuits.
3. Run the engine at idle (500–800 rpm) in **N** (Neutral) for about one minute.
4. Remove the dipstick and wipe it clean. Insert the dipstick into the fill tube, pushing down until it stops.
5. Remove the dipstick and observe the fluid level. If the fluid on the dipstick is within the COLD CHECK band (refer to Figure 11), the level is satisfactory. If the fluid level **is not** within this band, add or drain fluid as necessary to bring the level within the COLD CHECK band.
6. Perform a HOT CHECK at the first opportunity after normal operating temperature (71°–93°C; 160°–200°F) is reached.



**CAUTION:** DO NOT operate the transmission for extended periods of time until a HOT CHECK has verified proper fluid level. Transmission damage can result from extended operation at improper fluid level conditions.



**CAUTION:** Obtain an accurate fluid level by imposing the following conditions:

- Engine is idling (500–800 rpm) in N (Neutral)
- Transmission fluid is at the normal operating temperature
- The vehicle is on a level surface

## HOT CHECK

The transmission fluid **must be hot** to obtain an accurate reading, because the fluid level rises as the temperature increases.

To perform a HOT CHECK, do the following:

1. Be sure fluid has reached normal operating temperature (71°–93°C; 160°–200°F). If a transmission temperature gauge is not present, measure fluid level when the engine water temperature gauge has stabilized and the transmission has been operated under load for at least one hour.
2. Park the vehicle on a level surface and shift to N (Neutral). Apply the parking brake and allow the engine to idle (500–800 rpm).
3. Remove the dipstick and wipe it clean. Insert the dipstick into the fill tube, pushing down until it stops.
4. Remove the dipstick and observe the fluid level. The safe operating level is anywhere within the HOT RUN band (refer to Figure 11) on the dipstick.
5. If the level is not within this band, add or drain fluid as necessary to bring the level within the HOT RUN band.
6. Be sure fluid level measurements are consistent. Measure fluid level more than once and if readings are not consistent, be sure the transmission breather is clean and not clogged. If readings are still not consistent, contact your nearest Allison distributor or dealer.

## RECOMMENDED AUTOMATIC TRANSMISSION FLUID AND VISCOSITY GRADE

Proper transmission fluid selection is important to transmission performance, reliability, and durability. The following is a list, by preference of use, of Allison approved transmission fluids.



**NOTE:** Consult the Allison Transmission web site at [www.allisontransmission.com](http://www.allisontransmission.com) for a current list of approved transmission fluids. Select SERVICE, then Fluids.

- **TES 295 approved fluids (required for MY09 Prognostics):**
  - Recommended for all 3000 and 4000 Product Families transmission applications
  - Fully qualified to the Allison TES 295 specification for Severe Duty and Extended Drain Intervals
  - Available through Allison distributors and dealerships
- TES 389 approved fluid:
  - May be used in all 3000 and 4000 Product Families transmission applications
  - **Must use** Allison approved Non-TES 295 fluid/filter change schedule that was previously assigned to DEXRON<sup>®</sup>-III fluid.
- DEXRON<sup>®</sup>-VI approved fluid:
  - As of January 1, 2007, General Motors will no longer license DEXRON<sup>®</sup>-III fluids. DEXRON<sup>®</sup>-VI fluids are suitable replacements.
  - DEXRON<sup>®</sup>-VI may be used in all 3000 and 4000 Product Families transmission applications after February 1, 2007, starting with serial number 6510717075 for 3000 Product Family transmissions and serial number 6610220990 for all 4000 Product Family transmissions.
  - **Must use** the Allison approved Non-TES 295 fluid/filter change schedule that was previously assigned to DEXRON<sup>®</sup>-III fluid.
- When choosing the optimum viscosity grade of fluid, duty cycle, preheat capabilities, and/or geographical location **must be** taken into consideration. The Transmission Fluid Operating Temperature Requirements table lists the minimum fluid temperatures at which the transmission may be safely operated without preheating. Preheat with auxiliary heating equipment or by running the equipment or vehicle with the transmission in neutral for a minimum of 20 minutes before attempting range operation.



**CAUTION:** Disregarding minimum fluid temperature limits may result in transmission malfunction or reduced transmission life.

## Transmission Fluid Minimum Operating Temperature Requirements

SAE Viscosity Grade* or Fluid Type	Minimum Operating Temperature	
	Celsius	Fahrenheit
SAE 0W-30	-30	-22
SAE 0W-20/TES 295	-35	-31
DEXRON <sup>®</sup> -VI/TES 389	-25	-13
SAE 10W	-25	-13
SAE 15W-40	-20	-4
SAE 30	0	32
SAE 40	10	50

\* SAE "W" designation indicates winter weight based on cold temperature properties.

## KEEPING FLUID CLEAN



**CAUTION:** Containers or fillers that have been used for antifreeze solution or engine coolant must **NEVER** be used for transmission fluid. Antifreeze and coolant solutions contain ethylene glycol which, if put into the transmission, can cause the clutch plates and some seals to fail.

It is absolutely necessary that transmission fluid be clean. The fluid **must be handled** in clean containers to prevent foreign material from entering the transmission.

## ALLISON 4<sup>TH</sup> GENERATION AND MY09 PROGNOSTICS DISABLED FLUID AND INTERNAL FILTER CHANGE INTERVAL RECOMMENDATIONS



**NOTE:** This section is to be used for all Allison 4<sup>th</sup> Generation transmissions with MY09 Prognostics **DISABLED**. Refer to Table 5 through Table 8 in this section.



**CAUTION:** Transmission fluid and filter change frequency is determined by the severity of transmission service. To help avoid transmission damage, more frequent changes may be necessary than recommended in the general guidelines due to operating conditions and duty cycle.



**NOTE:** Change fluid/filters at or before recommended mileage, months, or hours have elapsed, whichever occurs first. For vehicles that average less than 25 mph (40 kmh), operating hours represent a more reliable measure of fluid life; therefore, fluid change intervals should not be based on mileage only.

---

Allison Transmission requires all 3000 and 4000 Product Families transmissions using the **Gold Series filter** to change the main filter (not the lube filter) **after the first 5000 miles (8000 km) or 200 hours of operation**, whichever occurs first. Gold Series filters may be identified by part numbers 29538231 or 29538232 stamped into the filter end cap.

Beginning with serial numbers 6510670912, 6610205144, 6520067342, and 6620002521, transmissions equipped with the Allison High Capacity filter **do not require an initial main filter change at 5000 miles (8000 km) or 200 hours**. High Capacity filters may be identified by part numbers 29545777 (3000 Product Family) or 29545780 (4000 Product Family) stamped into the filter end cap.

Refer to the latest revision of Service Tips #1099 for convenient kit and fluid information. Refer to the appropriate mechanic's tips, latest revision, for location of the main filter and fluid/filter change procedures. The latest revision of Service Tips #1099 is available on the Allison Transmission web site under service. The latest revision of the appropriate mechanic's tips is available on the Allison Transmission web site under publications. The web site is located at [www.allisontransmission.com](http://www.allisontransmission.com).



**CAUTION:** Transmission fluid and filters **must be changed** whenever there is evidence of dirt or high temperature conditions. A high temperature condition is indicated when the transmission fluid is discolored, has a strong odor, or has exceeded oil analysis limits.



**Table 5. Recommended Fluid/Filter Change Intervals for 3000 Product Family Transmissions with Gold Series Filter**

**NOTE:** Change fluid/filters at or before recommended mileage, months, or hours have elapsed, whichever occurs first.

**NOTE:** Local conditions, severity of operation or duty cycle may require more or less frequent fluid change intervals that differ from the published recommended fluid change intervals of Allison Transmission. Allison Transmission recommends that the customer use fluid analysis as the primary method for determining fluid change intervals. In the absence of a fluid analysis program, the fluid change intervals listed in the chart should be used.

<b>SEVERE VOCATION*</b>				<b>GENERAL VOCATION**</b>			
<b>Fluid</b>		<b>Filters</b>		<b>Fluid</b>		<b>Filters</b>	
		<b>Main</b>	<b>Internal</b>			<b>Main</b>	<b>Internal</b>
		<b>Lube/Auxiliary</b>	<b>Lube/Auxiliary</b>			<b>Main</b>	<b>Lube/Auxiliary</b>
<b>Schedule 1—Non-TES 295 Fluid</b>							
12,000 Miles (20 000 km) 6 Months 500 Hours	12,000 Miles (20 000 km) 6 Months 500 Hours	Overhaul	Overhaul	25,000 Miles (40 000 km) 12 Months 1000 Hours	25,000 Miles (40 000 km) 12 Months 1000 Hours	Overhaul	25,000 Miles (40 000 km) 12 Months 1000 Hours
<b>Schedule 2—TES 295 Fluid***</b>							
75,000 Miles (120 000 km) 36 Months 3000 Hours	75,000 Miles (120 000 km) 36 Months 3000 Hours	Overhaul	Overhaul	150,000 Miles (240 000 km) 48 Months 4000 Hours	75,000 Miles (120 000 km) 36 Months 3000 Hours	Overhaul	75,000 Miles (120 000 km) 36 Months 3000 Hours

\* Transmissions with retarders or on/off highway.

\*\* Transmissions without retarders and on highway only.

\*\*\* Recommendations in Schedule 2 are based on the transmission containing 100 percent TES 295 fluid and Allison Transmission Gold Series filters.

**Table 6. Recommended Fluid/Filter Change Intervals for 4000 Product Family Transmissions with Gold Series Filter**

**NOTE:** Change fluid/filters at or before recommended mileage, months, or hours have elapsed, whichever occurs first.

**NOTE:** Local conditions, severity of operation or duty cycle may require more or less frequent fluid change intervals that differ from the published recommended fluid change intervals of Allison Transmission. Allison Transmission recommends that the customer use fluid analysis as the primary method for determining fluid change intervals. In the absence of a fluid analysis program, the fluid change intervals listed in the chart should be used.

<b>SEVERE VOCATION*</b>			<b>GENERAL VOCATION**</b>				
<b>Filters</b>			<b>Filters</b>				
<b>Fluid</b>	<b>Main</b>	<b>Internal</b>	<b>Lube/Auxiliary</b>	<b>Fluid</b>	<b>Main</b>	<b>Internal</b>	<b>Lube/Auxiliary</b>
<b>Schedule 1—Non-TES 295 Fluid</b>							
12,000 Miles (20 000 km) 6 Months 500 Hours	12,000 Miles (20 000 km) 6 Months 500 Hours	Overhaul	12,000 Miles (20 000 km) 6 Months 500 Hours	25,000 Miles (40 000 km) 12 Months 1000 Hours	25,000 Miles (40 000 km) 12 Months 1000 Hours	Overhaul	25,000 Miles (40 000 km) 12 Months 1000 Hours
<b>Schedule 2—TES 295 Fluid***</b>							
<b>4 Inch Control Module (3.5 Inch Approximately)</b>							
75,000 Miles (120 000 km) 36 Months 3000 Hours	75,000 Miles (120 000 km) 36 Months 3000 Hours	Overhaul	75,000 Miles (120 000 km) 36 Months 3000 Hours	150,000 Miles (240 000 km) 48 Months 4000 Hours	75,000 Miles (120 000 km) 36 Months 3000 Hours	Overhaul	75,000 Miles (120 000 km) 36 Months 3000 Hours

\* Transmissions with retarders or on/off highway.

\*\* Transmissions without retarders and on highway only.

\*\*\* Recommendations in Schedule 2 are based on the transmission containing 100 percent TES 295 fluid and Allison Transmission Gold Series filters.

**Table 6. Recommended Fluid/Filter Change Intervals for  
4000 Product Family Transmissions With Gold Series Filter (cont'd)**

**NOTE:** Severe and General Vocations—local conditions, severity of operation, or duty cycle may require more or less frequent fluid change intervals that differ from the published recommended fluid change intervals of Allison Transmission. Transmission protection and fluid change intervals can be optimized by using fluid analysis. Filters **must be changed** at or before recommended intervals. Change fluid/filter after recommended mileage, months, or hours have elapsed, whichever comes first.

<b>SEVERE VOCATION*</b>				<b>GENERAL VOCATION**</b>			
<b>Filters</b>				<b>Filters</b>			
<b>Fluid</b>	<b>Main</b>	<b>Internal</b>	<b>Lube/ Auxiliary</b>	<b>Fluid</b>	<b>Main</b>	<b>Internal</b>	<b>Lube/ Auxiliary</b>
<b>Schedule 3—TES 295 Fluid***</b>							
<b>2 Inch Control Module (1.75 Inch Approximately)</b>							
50,000 Miles (80 000 km) 24 Months 2000 Hours	50,000 Miles (80 000 km) 24 Months 2000 Hours	Overhaul	50,000 Miles (80 000 km) 24 Months 2000 Hours	150,000 Miles (240 000 km) 48 Months 4000 Hours	50,000 Miles (80 000 km) 24 Months 2000 Hours	Overhaul	50,000 Miles (80 000 km) 24 Months 2000 Hours

\* Transmissions with retarders or on/off highway.

\*\* Transmissions without retarders and on highway only.

\*\*\* Recommendations in Schedule 2 and 3 are based on the transmission containing 100 percent TES 295 fluid and Allison Transmission Gold Series filters.

**Table 7. Recommended Fluid/Filter Change Intervals for 3000 Product Family Transmission with High Capacity Filter**

**NOTE:** Change fluid/filters at or before recommended mileage, months, or hours have elapsed, whichever occurs first.

**NOTE:** Local conditions, severity of operation or duty cycle may require more or less frequent fluid change intervals that differ from the published recommended fluid change intervals of Allison Transmission. Allison Transmission recommends that the customer use fluid analysis as the primary method for determining fluid change intervals. In the absence of a fluid analysis program the fluid change intervals listed in the chart should be used.

<b>SEVERE VOCATION*</b>			<b>GENERAL VOCATION**</b>				
<b>Filters</b>			<b>Filters</b>				
<b>Fluid</b>	<b>Main</b>	<b>Internal</b>	<b>Lube/ Auxiliary</b>	<b>Fluid</b>	<b>Main</b>	<b>Internal</b>	<b>Lube/ Auxiliary</b>
<b>Schedule 1—Non-TES 295 Fluid</b>							
12,000 Miles (20 000 km) 6 Months 500 Hours	12,000 Miles (20 000 km) 6 Months 500 Hours	Overhaul	12,000 Miles (20 000 km) 6 Months 500 Hours	25,000 Miles (40 000 km) 12 Months 1000 Hours	25,000 Miles (40 000 km) 12 Months 1000 Hours	Overhaul	25,000 Miles (40 000 km) 12 Months 1000 Hours
<b>Schedule 2—TES 295 Fluid***</b>							
150,000 Miles (240 000 km) 48 Months 6000 Hours	75,000 Miles (120 000 km) 36 Months 3000 Hours	Overhaul	75,000 Miles (120 000 km) 36 Months 3000 Hours	300,000 Miles (480 000 km) 48 Months 6000 Hours	75,000 Miles (120 000 km) 36 Months 3000 Hours	Overhaul	75,000 Miles (120 000 km) 36 Months 3000 Hours

\* Transmissions with retarders or on/off highway.

\*\* Transmissions without retarders and on highway only.

\*\*\* Recommendations in Schedule 2 are based on the transmission containing 100 percent TES 295 fluid and Allison Transmission Gold Series filters.

**Table 8. Recommended Fluid/Filter Change Intervals for 4000 Product Family Transmissions with High Capacity Filter**

**NOTE:** Change fluid/filters at or before recommended mileage, months, or hours have elapsed, whichever occurs first.

**NOTE:** Local conditions, severity of operation or duty cycle may require more or less frequent fluid change intervals that differ from the published recommended fluid change intervals of Allison Transmission. Allison Transmission recommends that the customer use fluid analysis as the primary method for determining fluid change intervals. In the absence of a fluid analysis program the fluid change intervals listed in the chart should be used.

<b>SEVERE VOCATION*</b>				<b>GENERAL VOCATION**</b>			
<b>Filters</b>				<b>Filters</b>			
<b>Fluid</b>	<b>Main</b>	<b>Internal</b>	<b>Lube/Auxiliary</b>	<b>Fluid</b>	<b>Main</b>	<b>Internal</b>	<b>Lube/Auxiliary</b>
<b>Schedule 1—Non-TES 295 Fluid</b>							
12,000 Miles (20 000 km) 6 Months 500 Hours	12,000 Miles (20 000 km) 6 Months 500 Hours	Overhaul	12,000 Miles (20 000 km) 6 Months 500 Hours	25,000 Miles (40 000 km) 12 Months 1000 Hours	25,000 Miles (40 000 km) 12 Months 1000 Hours	Overhaul	25,000 Miles (40 000 km) 12 Months 1000 Hours
<b>Schedule 2—100 Percent TES 295 Fluid</b>							
<b>2 Inch (1.75 Inch Approximately) and 4 Inch (3.5 Inch Approximately) Control Modules***</b>							
150,000 Miles (240 000 km) 48 Months 6000 Hours	75,000 Miles (120 000 km) 36 Months 3000 Hours	Overhaul	75,000 Miles (120 000 km) 36 Months 3000 Hours	300,000 Miles (480 000 km) 48 Months 6000 Hours	75,000 Miles (120 000 km) 36 Months 3000 Hours	Overhaul	75,000 Miles (120 000 km) 36 Months 3000 Hours

\* Transmissions with retarders or on/off highway.

\*\* Transmissions without retarders and on highway only.

\*\*\* 2 inch Control Module requires Filter Kit P/N 29545776; 4 inch Control Module requires Filter Kit P/N 29545779

# ALLISON 4<sup>TH</sup> GENERATION MY09 PROGNOSTICS ENABLED FLUID AND FILTER CHANGE INTERVAL RECOMMENDATIONS

---



**NOTE:** This section is to be used for 3000 Product Family 3-, 4-, 5-, and 6-speed transmissions only with MY09 Prognostics **ENABLED**.

---



**CAUTION:** Transmission fluid and filter change frequency is determined by the severity of transmission service. To help avoid transmission damage, more frequent changes may be necessary than recommended in the general guidelines due to operating conditions and duty cycle.

---



**NOTE:** Change fluid/filters at or before recommended mileage, months, or hours have elapsed, whichever occurs first. For vehicles that average less than 25 mph (40 kmh), operating hours represent a more reliable measure of fluid life; therefore, fluid change intervals should not be based on mileage only.

---



**CAUTION:** Transmission fluid and filters **must be changed** whenever there is evidence of dirt or high temperature conditions. A high temperature condition is indicated when the transmission fluid is discolored, has a strong odor, or has exceeded oil analysis limits.

---

Fluid (OM) and filter (FM) Prognostics parameters provide indicators of required maintenance actions. They are designed to maximize fluid and filter utilization. **Prognostics enabled requires the use of Allison approved TES 295 transmission fluids and Allison High Capacity Filters.** If any other fluids or filters are used, Prognostics **must be DISABLED**. Prognostics information will not be accurate with any other transmission fluid or filter and could result in missed maintenance activities resulting in transmission damage.

For new vehicles delivered from the OEM with a mixture of TES 295 and Non-TES 295 fluid, Prognostics **must be** turned off and fluid/filter changes **must follow** the recommendations in Table 7 and Table 8. If the customer fills the transmission with Allison-approved TES 295 fluid, the change recommendations of Allison-approved Non-TES 295 fluids **MUST BE FOLLOWED**. At the next fluid change, if the customer fills with Allison-approved TES 295 fluid and uses Allison High Capacity Filters, Prognostics can be “turned on”, if available, and Table 9 recommendations **may be followed**.

**Table 9. Recommended Fluid/Filter Change Intervals for MY09 Prognostics Enabled 3000 and 4000 Product Families Transmissions**

**NOTE:** This schedule is to be used with Prognostics “ON” beginning with the serial numbers listed in Service Tips #1099. Go to [www.allisontransmission.com](http://www.allisontransmission.com) and click SERVICE, Fluids, then Service Tips for the current revision.

**NOTE:** 100 percent concentration of TES 295 Allison approved fluids and Allison High Capacity Filters is REQUIRED. Less than 100 percent concentration of TES 295 Allison approved fluids are considered a mixture and shall not be used with MY09 Prognostics or this change schedule. Utilization of previous Non-TES 295 Fluid/Filter Change Intervals tables is required.

**NOTE:** Fluid fill capacity is dependent on vehicle configuration. Final fluid capacity must be determined by dipstick level (refer to Mechanic’s Tips, MT3004EN, Refill Transmission Section 2–8c, or Operator’s Manual, CARE AND MAINTENANCE section).

<b>General or Severe Vocation</b>	
<b>Fluids–Prognostics ON*</b>	<b>Filters–Prognostics ON*</b>
Change fluid when indicated by controller or 60 months (five years) whichever occurs first. Also change filters with fluid	Change filters when indicated by controller between fluid changes or 60 months (five years) whichever occurs first.
<b>Internal</b>	<b>Overhaul only</b>
* If Prognostics is turned OFF or not calibrated in the TCM after the serial numbers listed in Service Tips #1099, utilization of Table 7 or Table 8 fluid change intervals is required.	

## FLUID ANALYSIS

Transmissions used in high cycle rate applications should use fluid analysis to make sure fluid is changed as soon as needed. Transmission protection and fluid change intervals may be optimized by monitoring fluid oxidation according to the tests and limits shown in the fluid oxidation measurement limits table. Consult your local telephone directory for fluid analysis firms. To be sure of consistent and accurate fluid analysis, use only one fluid analysis firm. Refer to Technician's Guide for Automatic Transmission Fluid, GN2055EN, for additional information.

### Fluid Oxidation Measurement Limits

Test	Limit
Viscosity	±25 percent change from new fluid
Total Acid Number (TAN)	+3.0* change from new fluid
Solids	2 percent by volume
* mg of potassium hydroxide (KOH) to neutralize a gram of fluid.	

## REFILL TRANSMISSION

The amount of refill fluid is less than the amount used for the initial fill. Fluid remains in the external circuits and transmission cavities after draining the transmission.

After refill, determine that the fluid level is correct using the FLUID LEVEL CHECK USING PUSHBUTTON OR LEVER SHIFT SELECTOR section of this manual.



**NOTE:** Quantities listed are approximations and do not include external lines and cooler hose.

### Transmission Fluid Capacity

Transmission	Sump	Initial Fill		Refill	
		Liters	Quarts	Liters	Quarts
3000 Product Family	7 inch*	37	39	30	32
	4 inch	27	29	18	19
	2 inch	25	26	16	17
4000 Product Family**	4 inch	45	48	37	39
	2 inch	38	40	30	31

\* Standard on 3000 Product Family 7-Speed transmissions.

\*\* Subtract 2.8 Liters (3 Quarts) for transmissions without PTO.



# DIAGNOSTICS

## DIAGNOSTIC CODES

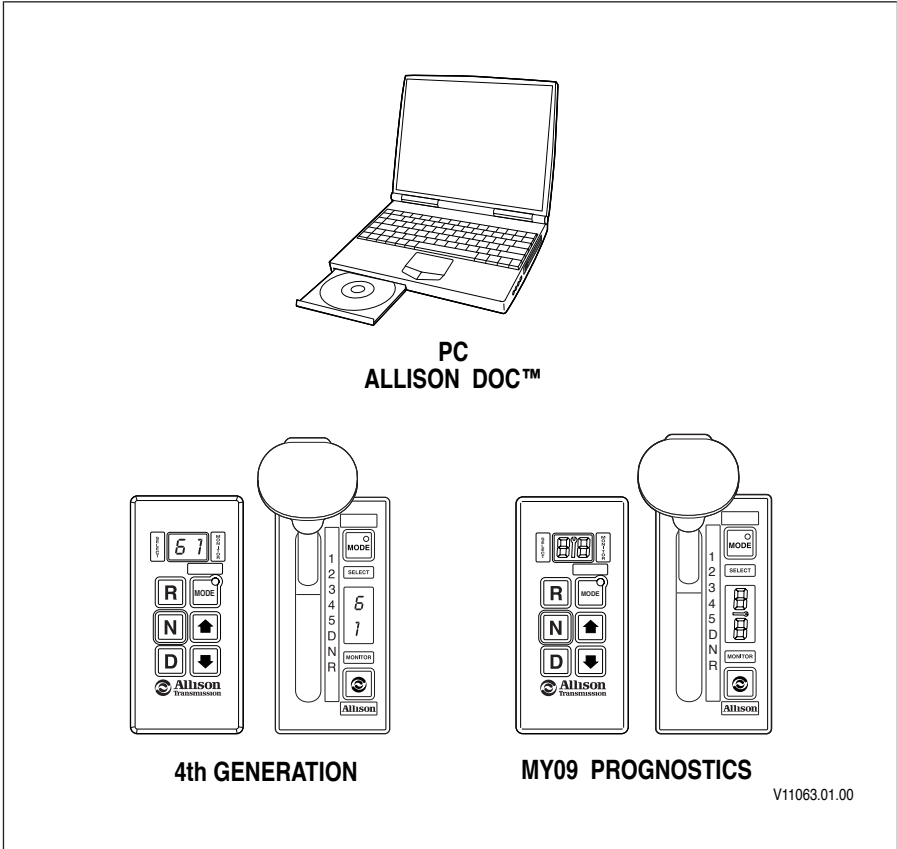

Figure 12. Shift Selectors and Allison DOC™ For PC–Service Tool

Poor performance may activate a diagnostic code without illuminating the **CHECK TRANS** light. Continued illumination of the **CHECK TRANS** light during vehicle operation (not start-up) indicates the TCM/ECU has signaled a diagnostic code. Up to five diagnostic codes may be recorded. Diagnostic codes may be read and cancelled by the Allison DOC™ For PC–Service Tool or Allison shift selectors shown in Figure 12. Code reading, clearing methods, and complete code descriptions are available in the troubleshooting manual for your transmission. Refer to the SERVICE LITERATURE section for the appropriate publication. For more information on accessing and clearing codes refer to the following paragraphs.

**Allison 4<sup>th</sup> Generation, MY09 Prognostics DISABLED, and Seven-Speed Transmissions Diagnostic Codes.** To clear diagnostic codes using the Allison shift selectors shown in Figure 12, refer to the code reading and clearing methods described in ALLISON 4<sup>TH</sup> GENERATION DIAGNOSTIC CODE DISPLAY PROCEDURE in the DRIVING TIPS section.

**Allison 4<sup>th</sup> Generation MY09 Prognostics Diagnostic Code.** To clear diagnostic codes using the Allison shift selectors shown in Figure 12, refer to the code reading and clearing methods described in ALLISON 4<sup>TH</sup> GENERATION MY09 PROGNOSTICS DIAGNOSTIC CODE DISPLAY PROCEDURE in the DRIVING TIPS section.

---

# CUSTOMER SERVICE

---

## OWNER ASSISTANCE

The satisfaction and goodwill of the owners of Allison transmissions are of primary concern to Allison Transmission, its distributors, and their dealers.

As an owner of an Allison transmission, you have service locations throughout the world that are eager to meet your parts and service needs with:

- Expert service by trained personnel.
- Emergency service 24 hours a day in many areas.
- Complete parts support.
- Sales teams to help determine your transmission requirements.
- Product information and literature.

Normally, any situation that arises in connection with the sale, operation, or service of your transmission will be handled by the distributor or dealer in your area. Check the telephone directory for the Allison Transmission service outlet nearest you or utilize Allison Transmission's Sales and Service Locator tool on the Allison Transmission web site at [www.allisontransmission.com](http://www.allisontransmission.com). You may also refer to Allison Transmission's Worldwide Sales and Service Directory (SA2229EN).

We recognize, however, that despite the best intentions of everyone concerned, misunderstandings may occur. To further assure your complete satisfaction, we have developed the following three-step procedure to be followed in the event a problem has not been handled satisfactorily.

**Step One—Discuss your problem with a member of management from the distributorship or dealership.** Frequently, complaints are the result of a breakdown in communication and can quickly be resolved by a member of management. If you have already discussed the problem with the Sales or Service Manager, contact the General Manager. All Allison Transmission dealers are associated with an Allison Transmission distributor. If the problem originates with a dealer, explain the matter to a management member of the distributorship with whom the dealer has his service agreement. The dealer will provide his Allison Transmission distributor's name, address, and telephone number on request.

**Step Two**—When it appears the problem cannot be readily resolved at the distributor level without additional assistance, **contact the Allison Technical Assistance Center at 800-252-5283**. They will place you in contact with the Regional Customer Support Manager for your area.

For prompt assistance, please have the following information available:

- Name and location of authorized distributor or dealer.
- Type and make of vehicle/equipment.
- Transmission model number, serial number, and assembly number (if equipped with electronic controls, also provide the TCM assembly number).
- Transmission delivery date and accumulated miles and/or hours of operation.
- Nature of problem.
- Chronological summary of your transmission's history.

**Step Three**—If you are still not satisfied after contacting the Regional Customer Support Manager, **present the entire matter to the Home Office by writing to the following address:**

Allison Transmission  
Manager, Warranty Administration  
PO Box 894, Mail Code PF9  
Indianapolis, IN 46206-0894

The inclusion of all pertinent information will assist the Home Office in expediting the matter.

When contacting the Home Office, please keep in mind that ultimately the problem will likely be resolved at the distributorship or dealership using their facilities, equipment, and personnel. Therefore, it is suggested that **Step One** be followed when experiencing a problem.

Your purchase of an Allison Transmission product is greatly appreciated, and it is our sincere desire to assure complete satisfaction.

## SERVICE LITERATURE

Additional service literature is available as shown in the service literature table. This service literature provides fully illustrated instructions for the operation, maintenance, service, overhaul, and parts support of your transmission. To be sure that you get maximum performance and service life from your unit, you may order publications from:

SGI, Inc.

Attn: Allison Literature Fulfillment Desk

8350 Allison Avenue

Indianapolis, IN 46268

TOLL FREE: 888-666-5799

INTERNATIONAL: 317-471-4995

### Available Service Literature (Allison 4<sup>th</sup> Generation Controls)

Publication Type	3000	4000
Allison DOC™ For PC User Guide	GN3433EN	GN3433EN
Mechanic's Tips (except 3700 7-speed) *	MT4015EN	MT4015EN
Mechanic's Tips (7-speed)*	MT4108EN	NA
Parts Catalog*	PC2150EN	PC2456EN
Parts Catalog on CD	CD2150EN	CD2456EN
Principles of Operation	PO4016EN	PO4016EN
Service Manual	SM4013EN	SM4014EN
Troubleshooting Manual	TS3989EN	TS3989EN
Worldwide Sales and Service Directory*	SA2229EN	SA2229EN

\* Also available on the Allison Transmission web site at [www.allisontransmission.com](http://www.allisontransmission.com)

## ALLISON TRANSMISSION REGIONAL OFFICES

### WORLDWIDE HEADQUARTERS

#### NORTH AMERICA

Allison Transmission, Inc.  
4700 West 10th Street  
Mail Code PF-9  
Indianapolis, IN 46222  
Phone: (800) 524-2303  
Fax: (317) 242-3123

#### SOUTH AMERICA

Allison Transmission Brasil  
Rua Agostinho Togneri, 57-  
Jardim Jurubatuba – Santo Amaro  
Sao Paulo -SP-, Brazil  
CEP 04690-090  
Phone: +55-11-5633-2599  
Phone: +55-11-5633+Ext  
Fax: +55-11-5633-2550

#### EUROPE, MIDDLE EAST, AFRICA, AND INDIA

Allison Transmission Europe B.V.  
Baanhoek 188  
3361 GN Sliedrecht, The Netherlands  
Phone: +31-78-6422-100  
Phone: 31-78-6422+Ext  
Fax: 31-78-6152-587  
Mailing Address:  
P.O. Box 1225  
3360 BE Sliedrecht, The Netherlands

### ASIA PACIFIC

Allison Transmission China  
#88 Ri Bin Road, B Section,  
Wai Gao Qiao  
Free Trade Zone,  
Shanghai, China 200131  
Phone: 86-21-2898-7755  
Phone: 86-21-2898+Ext  
Fax: 86-21-2898-7790/7791

### KOREA

Allison Transmission Korea  
18Fl, Taesok Bldg., #275-5  
Yangjae-dong, Seocho-ku  
Seoul, Korea 137-895  
Phone: 82-2-3497 0401  
Fax: 82-2-3497 0457

### JAPAN

Allison Transmission Japan  
Shinagawa East One Tower 3F  
2-16-1, Konan Minato-ku  
Tokyo, Japan 108-0075  
Phone: 81-3-6718-1660  
Phone: 81-3-6718+Ext  
Fax: 81-3-6718-1661

