

# EJD 220

01.10 -

Operating instructions

GB

51132781

11.14

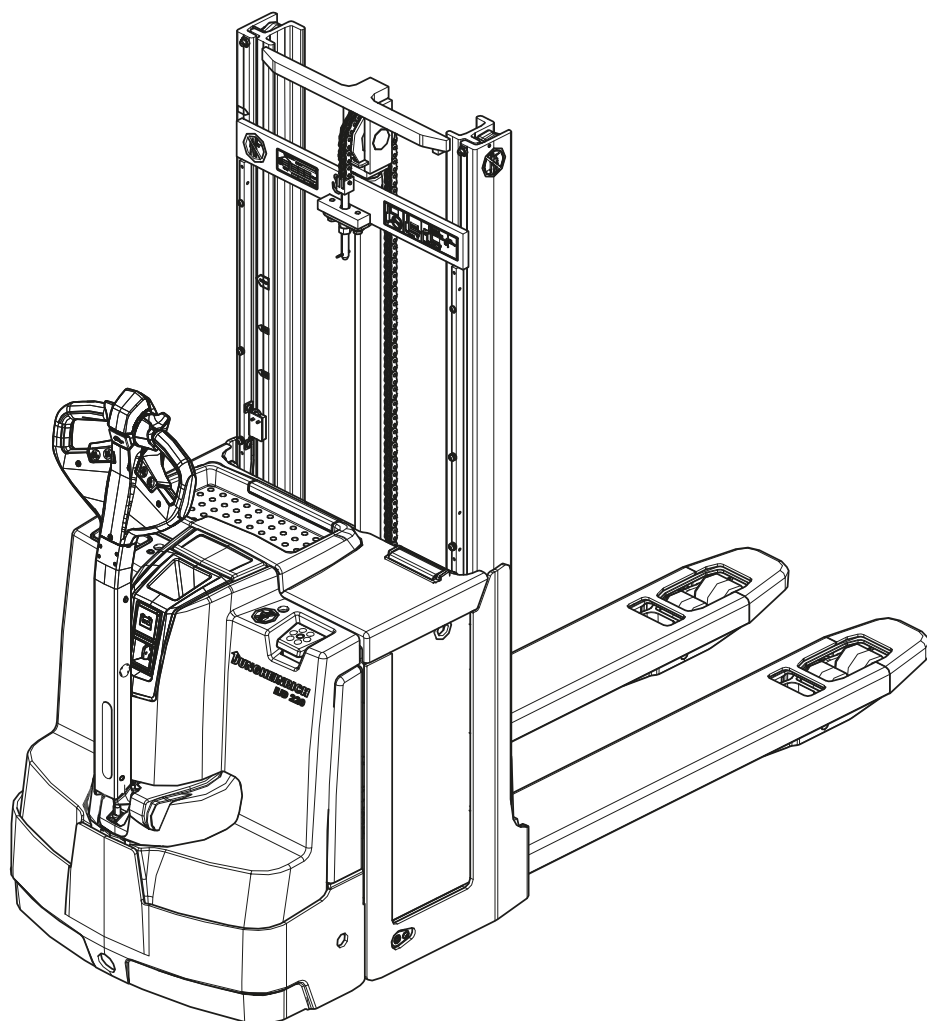

**JUNGHEINRICH**  
Machines. Ideas. Solutions.

# Declaration of Conformity



Jungheinrich AG, Am Stadtrand 35, D-22047 Hamburg  
Manufacturer or agent acting in the European Union

Type	Option	Serial no.	Year of manufacture
EJD 220			

## Additional information

On behalf of

Date

## EU Conformity Declaration

The undersigned hereby declare that the powered industrial truck described below in detail complies with the European Directives 2006/42/EC (Machinery Directive) and 2004/108/EEC (Electromagnetic Compatibility - EMC) including amendments as well as the legislative decree to incorporate the directives in national law. The signatories are in each case individually authorized to compile the technical documents.



# Foreword

## Notes on the operating instructions

The present ORIGINAL OPERATING INSTRUCTIONS are designed to provide sufficient instruction for the safe operation of the industrial truck. The information is provided clearly and concisely. The chapters are arranged by letter and the pages are numbered continuously.

The operator manual details different industrial truck models. When operating and servicing the industrial truck, make sure that the particular section applies to your truck model.

Our trucks are subject to ongoing development. We reserve the right to alter the design, equipment and technical features of the system. No guarantee of particular features of the truck should therefore be assumed from the present operating instructions.

## Safety notices and text mark-ups

Safety instructions and important explanations are indicated by the following graphics:

### **DANGER!**

Indicates an extremely hazardous situation. Failure to comply with this instruction will result in severe irreparable injury and even death.

---

### **WARNING!**

Indicates an extremely hazardous situation. Failure to comply with this instruction may result in severe irreparable injury and even death.

---

### **CAUTION!**

Indicates a hazardous situation. Failure to comply with this instruction may result in slight to medium injury.

---

### **NOTE**

Indicates a material hazard. Failure to comply with this instruction may result in material damage.

---



Used before notices and explanations.

- Indicates standard equipment
- Indicates optional equipment

## **Copyright**

Copyright of these operating instructions remains with JUNGHEINRICH AG.

## **Jungheinrich Aktiengesellschaft**

Am Stadtrand 35  
22047 Hamburg - Germany

Tel: +49 (0) 40/6948-0

[www.jungheinrich.com](http://www.jungheinrich.com)

# Contents

A	Correct Use and Application .....	11
1	General .....	11
2	Correct application.....	11
3	Approved application conditions.....	12
4	Proprietor responsibilities .....	13
5	Adding attachments and/or optional equipment .....	13
B	Truck Description .....	15
1	Application .....	15
1.1	Truck models and rated capacity.....	15
2	Travel direction definition.....	16
3	Assemblies and Functional Description.....	17
3.1	Assembly Overview .....	17
3.2	Functional Description .....	18
4	Technical Specifications .....	21
4.1	Performance data .....	21
4.2	Dimensions .....	22
4.3	Weights.....	24
4.4	Tyre type.....	24
4.5	EN norms.....	25
4.6	Conditions of use.....	26
4.7	Electrical Requirements.....	26
5	Identification Points and Data Plates .....	27
5.1	Indication Points .....	27
5.2	Data plate .....	29
5.3	Truck capacity plate.....	30
5.4	Wind loads.....	31
5.5	Double Decker Mode Capacity Plate.....	32
C	Transport and Commissioning .....	33
1	Lifting by crane .....	33
2	Transport .....	35
3	Using the Truck for the First Time .....	36
D	Battery - Servicing, Recharging, Replacement .....	37
1	Safety Regulations Governing the Handling of Lead-Acid Batteries .....	37
2	Battery types.....	39
3	Exposing the battery.....	40

4	Charging the battery .....	41
4.1	Charging the battery with a stationary charger .....	42
4.2	Charging the battery with an on-board charger (○) .....	43
5	Battery removal and installation .....	49
5.1	Lateral battery removal .....	50
<b>E</b>	<b>Operation .....</b>	<b>53</b>
1	Safety Regulations for the Operation of the Forklift Truck.....	53
2	Displays and Controls.....	55
2.1	Battery discharge monitor .....	58
2.2	Battery discharge indicator .....	59
3	Preparing the Truck for Operation .....	60
3.1	Checks and Operations to Be Performed Before Starting Daily Work ...	60
3.2	Preparing the truck for operation .....	61
3.3	Checks and operations to be carried out when the truck is operational ..	62
3.4	Parking the truck securely .....	63
4	Industrial Truck Operation .....	64
4.1	Safety regulations for truck operation.....	64
4.2	Emergency Disconnect.....	66
4.3	Automatic braking.....	68
4.4	Travel.....	69
4.5	Slow travel .....	72
4.6	Steering .....	72
4.7	Brakes .....	73
4.8	Load handler raise/lower .....	75
4.9	Lifting, transporting and depositing loads .....	78
5	Troubleshooting.....	86
5.1	Truck does not start.....	87
5.2	Load cannot be lifted .....	88
6	Operating the truck without its own drive system .....	89
6.1	Release and activate the drive wheel brake .....	89
7	Load handler emergency lowering .....	91
8	Optional equipment .....	92
8.1	Emergency operation with service key GF60 .....	92
8.2	CanCode Keypad (○).....	94
8.3	Setting the truck parameters with CanCode .....	113
8.4	Parameters .....	115
8.5	Setting the Battery Parameters with CanCode .....	120
8.6	CanDis Display Instrument (○) .....	122
8.7	ISM access module (○).....	123
<b>F</b>	<b>Industrial Truck Maintenance .....</b>	<b>125</b>
1	Operational Safety and Environmental Protection.....	125
2	Maintenance Safety Regulations.....	126
2.1	Working on the electrical system.....	127
2.2	Consumables and used parts.....	127
2.3	Wheels.....	127
2.4	Hydraulic system .....	128
2.5	Lift Chains.....	129

3	Lubricants and Lubrication Schedule .....	130
3.1	Handling consumables safely .....	130
3.2	Lubrication Schedule .....	132
3.3	Consumables.....	133
4	Maintenance and repairs .....	134
4.1	Preparing the truck for maintenance and repairs .....	134
4.2	Lifting and jacking up the truck safely.....	135
4.3	Cleaning .....	136
4.4	Front cover disassembly.....	139
4.5	Drive panel disassembly and assembly .....	139
4.6	Checking the hydraulic oil level .....	140
4.7	Check the gear oil level .....	141
4.8	Tightening the wheel nuts.....	142
4.9	Checking electrical fuses .....	143
4.10	Restoring the truck to service after maintenance and repairs .....	144
5	Decommissioning the Industrial Truck.....	145
5.1	Prior to decommissioning .....	145
5.2	Action to be taken during decommissioning .....	145
5.3	Restoring the truck to service after decommissioning .....	146
6	Safety tests to be performed at intervals and after unusual incidents .....	147
7	Final de-commissioning, disposal.....	147
8	Human vibration measurement .....	147
9	Servicing and Inspection .....	148
10	Maintenance checklist .....	149
10.1	Operating company .....	149
10.2	Customer Service .....	151





# Appendix

## JH Traction Battery Operating Instructions



These operating instructions apply only to Jungheinrich battery models. If using another brand, refer to the manufacturer's operating instructions.



# A Correct Use and Application

## 1 General

The truck must be used, operated and serviced in accordance with the present instructions. All other types of use are beyond its scope of application and may result in damage to personnel, the industrial truck or property.

## 2 Correct application

### NOTE

The maximum load and load distance are indicated on the capacity plate and must not be exceeded.

The load must rest on the load handler or be lifted by an attachment approved by the manufacturer.

The load must be fully raised, see "Lifting, transporting and depositing loads" on page 78.

- 
- Lifting and lowering loads.
  - Transporting lowered loads.
  - Do not travel with a raised load (>500 mm).  
In double-decker mode the load handler must not be raised higher than 1800 mm.  
The bottom load must be heavier than the top.
  - Do not carry or lift passengers.
  - Do not push or pull load units.

### 3 Approved application conditions

- Operation in industrial and commercial environments.
- Permissible temperature range 5°C to 40°C.
- Operation only on secure, level surfaces with sufficient capacity.
- Do not exceed the permissible surface and spot load limits on the travel routes.
- Operation only on routes that are visible and approved by the operating company.
- Negotiating inclines up to a maximum of 15 %.
- Do not travel across or at an angle on inclines. Travel with the load facing uphill.
- Operation in partially public traffic.



#### **WARNING!**

#### **Use under extreme conditions**

Using the truck under extreme conditions can result in malfunctions and accidents.

- ▶ Special equipment and authorisation are required if the truck is to be constantly used in extreme conditions, especially in dusty or corrosive atmospheres.
  - ▶ The truck cannot be used in areas at risk of explosion.
  - ▶ In adverse weather conditions (thunder, lightning) the industrial truck must not be operated outside or in endangered areas.
-

## 4 Proprietor responsibilities

For the purposes of the present operating instructions the “operating company” is defined as any natural or legal person who either uses the industrial truck himself, or on whose behalf it is used. In special cases (e.g. leasing or renting) the proprietor is considered the person who, in accordance with existing contractual agreements between the owner and user of the industrial truck, is charged with operational duties. The proprietor must ensure that the industrial truck is used only for the purpose it is intended for and that danger to life and limb of the user and third parties are excluded. Furthermore, accident prevention regulations, safety regulations and operating, servicing and repair guidelines must be followed. The operating company must ensure that all users have read and understood these operating instructions.

### **NOTE**

Failure to comply with the operating instructions invalidates the warranty. The same applies if improper work is carried out on the truck by the customer or third parties without the permission of the manufacturer.

---

## 5 Adding attachments and/or optional equipment

The mounting or installation of additional equipment which affects or enhances the performance of the industrial truck requires the written permission of the manufacturer. Local authority approval may also need to be obtained. Local authority approval however does not constitute the manufacturer’s approval.



# B Truck Description

## 1 Application

The EJD 220 is a three-wheel, electric tiller-operated pallet truck with a steered drive wheel and coupling unit

It is designed to be used on level surfaces for lifting, stacking and transporting goods. For transportation, two pallets can be stacked on top of each other. Open bottom pallets or roll cages can be lifted.

### 1.1 Truck models and rated capacity

The rated capacity depends on the model. The rated capacity can be derived from the model name.

EJD220

EJD	Model name
2	Series
20	Rated capacity x 100 kg

The rated capacity is not generally the same as the permissible capacity. The capacity can be found on the capacity plate attached to the truck.

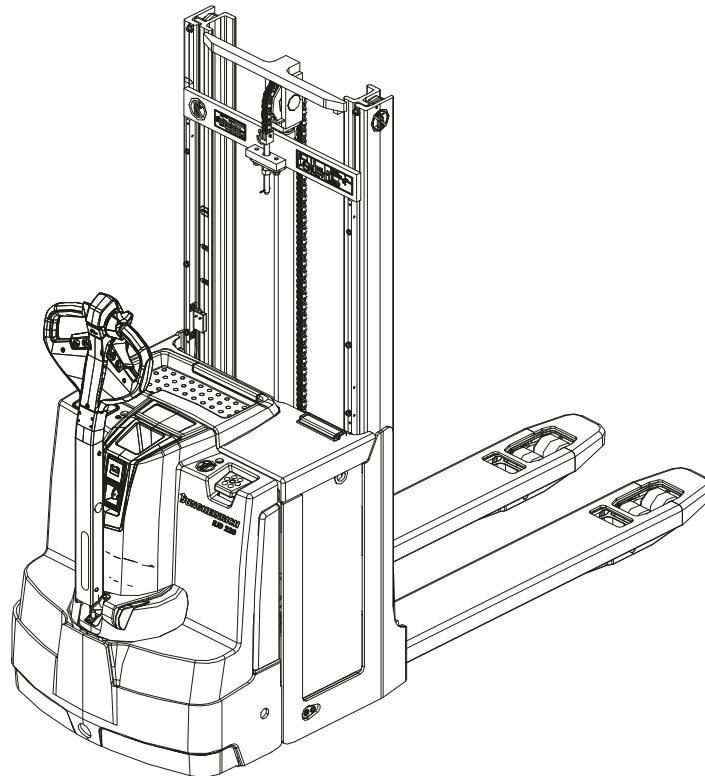



## 2 Travel direction definition

The following determinations have been made for travel direction specification:

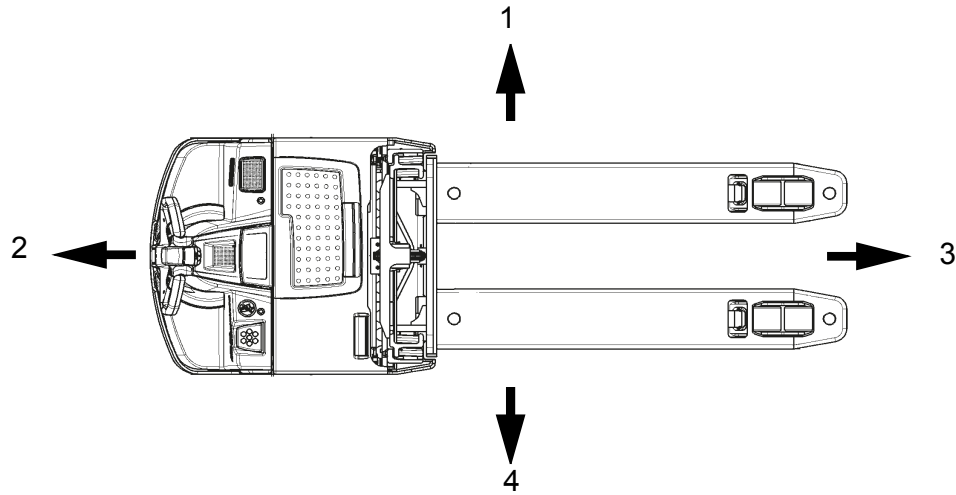

Item	Travel direction
1	Left
2	Drive direction
3	Load direction
4	Right

### 3 Assemblies and Functional Description

#### 3.1 Assembly Overview

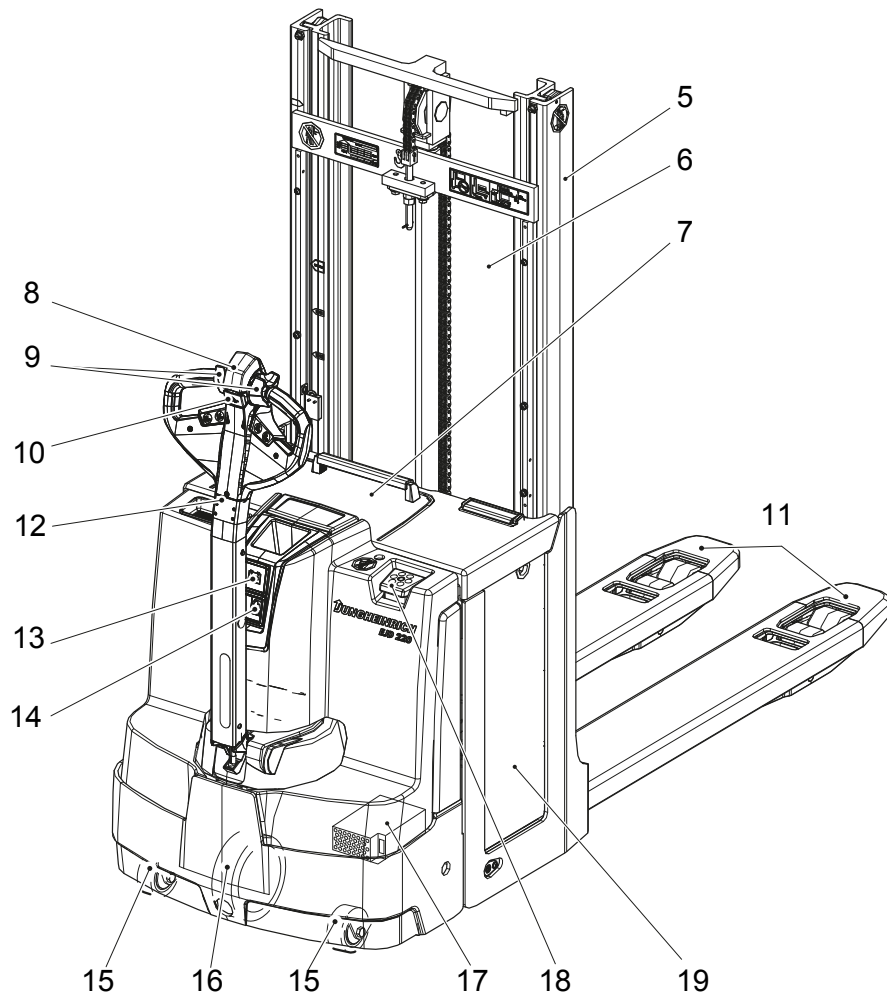

Item	Component	Item	Component
5	● Mast	13	● Charge display
6	● Mast protection pane	14	○ CanDis
	○ Protective grille (for cold store operation)		● Key switch
7	● Battery cover		○ CanCode
8	● Collision safety switch	○ ISM Access Module	
9	● Travel switch	15	● Support wheel
10	● Slow travel button	16	● Drive wheel
11	● Load handler	17	○ On-board charger
12	● Tiller	18	● Battery
		19	● Emergency Disconnect switch
● = Standard version		○ = Option	

## 3.2 Functional Description

### Safety mechanisms

An enclosed, smooth truck geometry with rounded edges ensures safe handling of the truck. The wheels are surrounded by a solid skirt.

The long tiller provides a maximum safety distance to the truck. When it is released and in hazardous situations, a gas strut forces the tiller up into the brake position. The collision safety switch in the tiller head responds to body contact, the travel direction changes and the truck moves away from the operator.

Activating the Emergency Disconnect switch rapidly cuts out all electrical functions in hazardous situations.

The mast protection pane or grille (○) protect the operator from moving mast parts and the load.

### Emergency Stop safety feature

The Emergency Stop is activated by the traction controller. Each time the truck is switched on the system performed a self diagnosis. If an error is detected, the truck automatically brakes to a halt. Control displays in the CanDis display instrument (○) indicate the Emergency Stop.

#### CAUTION!

#### The truck brakes automatically

If the truck detects that signals which are required have not been received, or if it detects an error, the system reacts by triggering an emergency stop, either by braking the truck to a halt or until a valid signal status has been reached.

► Remain at a suitable distance from the truck during operation.

---

## **Hydraulic System**

Lifting and lowering are activated via the lift and lower buttons. Pressing the lifting button starts the pump unit, supplying hydraulic oil from the oil reservoir to the lift cylinder. With the two-stage Duplex mast (ZZ) (○) or three-stage telescopic mast (DZ) (○) a short, centre-mounted free lift cylinder initially lifts the load handler (free lift) without changing the overall height of the truck.

## **Drive system**

A fixed AC three-phase motor actuates the drive wheel via a bevel spur gearbox. The electronic traction controller ensures smooth drive-motor-speed control and hence smooth starting, powerful acceleration and electrically controlled braking with energy regeneration. The driver can choose from 3 travel programs depending on the load and the environment: from high-performance to energy-saving.

## **Tiller**

The driver steers with an ergonomic tiller. All travel and lift operations can be performed sensitively without having to reach. The tiller has a steer angle of 180°.

## **Electrical system**

The truck has an electronic traction controller. The operating voltage of the truck's electrical system is 24 volts.

## **Controls and displays**

Ergonomic controls ensure fatigue-free operation for sensitive application of the travel and hydraulic operations. The battery discharge indicator shows the available battery capacity. The CanDis display (○) shows information which is important for the operator such as travel program, service hours, battery capacity and event messages.

## Mast

The high strength steel sections are narrow, enabling excellent visibility of the load handler. The lift rails and the load handler run on permanently-lubricated and hence maintenance-free angled rollers.

### Load backrest (○)

A load backrest is recommended as an additional protective mechanism to move low or small item loads above the mast protection frame or grille (○). The load backrest is mounted on the load handler and protects the operator and truck against falling loads.

- The extended mast height (h4) increases according to the load backrest mounted on the load handler.

### **WARNING!**

#### **Risk of injury from falling loads**

Low or small item loads moved above the mast protection pane or grille (○) and protruding over the load backrest can fall, endangering the operator and truck.

- ▶ Secure low or small item loads protruding over the load backrest, e.g. by wrapping them in film.
- 

### 3.2.1 Hourmeter

- Prepare the truck for operation, see "Preparing the truck for operation" on page 61 or see "CanCode Keypad (○)" on page 94.

Service hours are counted while the truck is operational and one of the following controls is applied:

- Tiller in travel zone "F", see "Travel" on page 69.
- "Slow travel button", see page 72.
- "Lift" button, see page 76.
- "Lower" button, see page 77.

## 4 Technical Specifications

- The technical specifications comply with the German "Industrial Truck Data Sheet" Guidelines.  
Technical modifications and additions reserved.

### 4.1 Performance data

		EJD 220	
Q	Rated capacity	2000	kg
	Capacity for mast lift <sup>1</sup>	1000	kg
	Capacity for support arm lift	2000	kg
D	Load centre distance	600	mm
	Travel speed with / without rated load	6.0 / 6.0	km/h
	Lift speed with / without rated load	0.14 / 0.25	m/s
	Lowering speed with / without rated load	0.40 / 0.40	m/s
	Max. gradeability (5 min.) with / without rated load	9 / 15	%
	Drive motor, Output S2 60 min	1.6	kW
	Lift motor, Output S3 10%	2.0	kW

1. Depends on lift height.

## 4.2 Dimensions

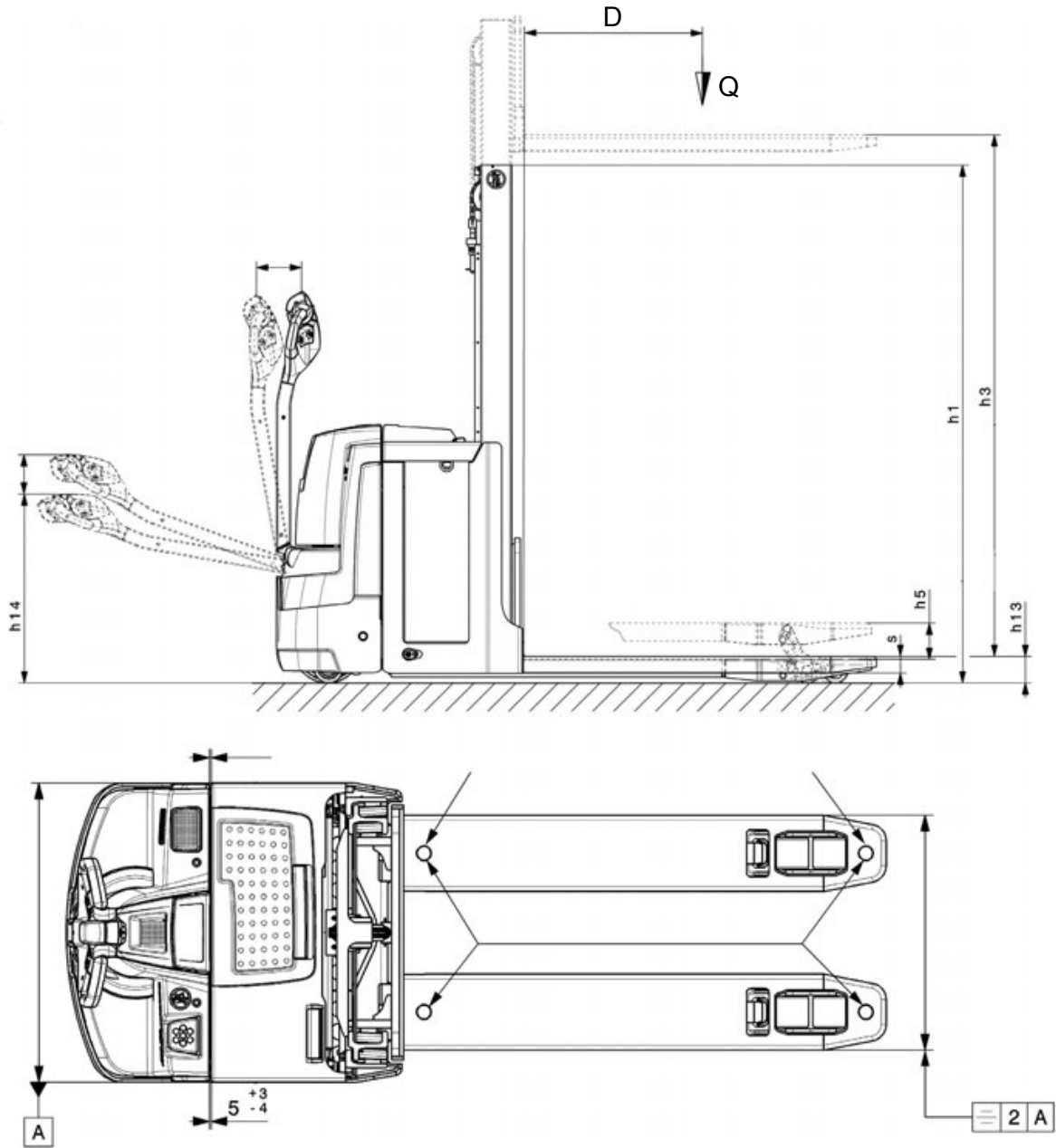

	Model	EJD 220	
x	Load distance 1)	957	mm
y	Wheel base 1) 4)	1617	mm
h3	Lift 5)	1660	mm
h5	Initial lift	122	mm
h13	Lowered height	90	mm
h14	Tiller height in the travel position min./max.	711 / 1320	mm
L1	Length 4)	2022	mm
L2	Fork length including fork shank 4)	832	mm
b1/2	Overall width (drive)	726	mm
b5	Width across forks	570	mm
s/e/l	Fork dimensions	56 / 185 / 1190	mm
b10	Track width, front	508	mm
b11	Track width, rear	385	mm
m2	Ground clearance, centre wheelbase	20	mm
Ast	Aisle width with pallet 1000x12000 traverse 2) 4)	2233	mm
Ast	Aisle width with pallet 800x1200 longit. 3) 4)	2243	mm
Wa	Turning radius 1) 4)	1800	mm
1) Load section lowered + 48 mm 2) Load section lowered + 48 mm; diagonal in accordance with VDI + 369 mm 3) Load section lowered + 48 mm; diagonal in accordance with VDI + 225 mm 4) Battery compartment M version / battery compartment L version = version M + 72 mm 5) Values for standard mast 166ZT			



### 4.3 Weights

	Net weight incl. battery M/L	937 / 1032	kg
	Axle loading, laden front/rear + battery	1120 / 1825 1160 / 1872	kg
	Axle loading, unladen front/rear + battery	665 / 280 732 / 300	kg
	Battery weight	220 / 288	kg

### 4.4 Tyre type

	Tyre size, drive	230 x 65	mm
	Load section tyre size (single / tandem)	85 x 95 / 85 x 75	mm
	Castor wheel	100 x 40	mm
	Wheels, number front/rear (x = driven)	1x +2 /2 or 4	mm

## 4.5 EN norms

### Noise emission level

– EJD 220:  $\leq 70$  dB(A)

in accordance with EN 12053 as harmonised with ISO 4871.

- The noise emission level is calculated in accordance with standard procedures and takes into account the noise level when travelling, lifting and when idle. The noise level is measured at the level of the driver's ear.

### Electromagnetic compatibility (EMC)

The manufacturer confirms that the truck adheres to the limits for electromagnetic emissions and resistance as well as the static electricity discharge test in accordance with EN 12895 as well as the standardised instructions contained therein.

- No changes to electric or electronic components or their arrangement may be made without the written agreement of the manufacturer.

### **WARNING!**

#### **Medical equipment can be damaged by non-ionised radiation**

Electrical equipment on the truck emitting non-ionised radiation (e.g. wireless data transmission) can affect operators' medical equipment (pacemakers, hearing aids etc.) and result in malfunctions. Consult a doctor or the manufacturer of the medical equipment to clarify whether it can be used near the industrial truck.

---

## 4.6 Conditions of use

### Ambient temperature

– operating at 5°C to 40°C



Special equipment and authorisation are required if the truck is to be used continually in conditions of extreme temperature or condensing air humidity fluctuations.

## 4.7 Electrical Requirements

The manufacturer certifies compliance with the requirements for the design and manufacture of electrical equipment, according to EN 1175 "Industrial Truck Safety - Electrical Requirements", provided the truck is used according to its purpose.

## 5 Identification Points and Data Plates

- Warnings and notices such as capacity charts, strap points and data plates must be legible at all times. Replace if necessary.

### 5.1 Indication Points

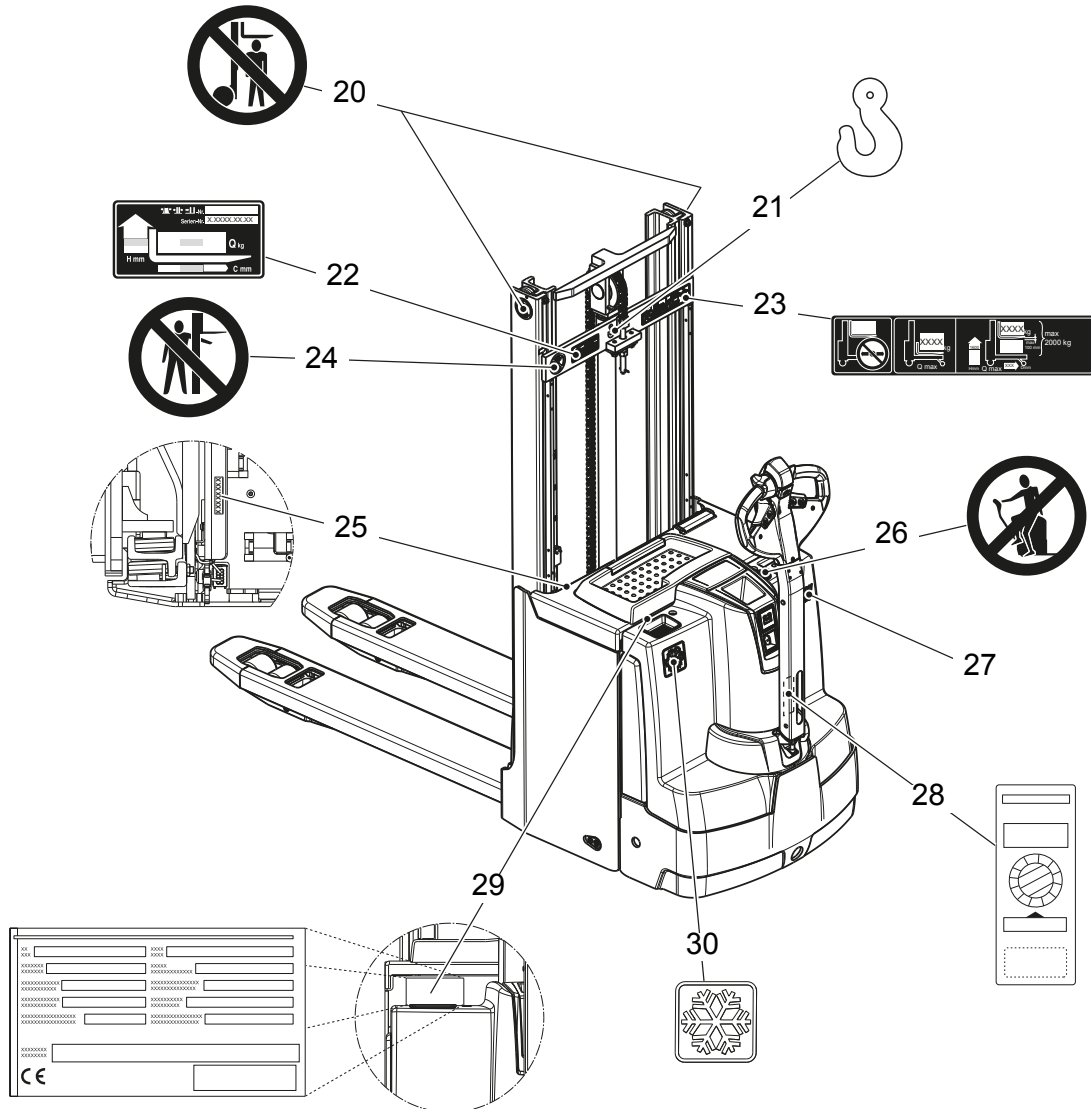

<b>Item</b>	<b>Component</b>
20	Warning: "Do not step under the load handler"
21	Attachment points for lifting by crane (with ZZ mast in the middle)
22	Capacity plate
23	Capacity Qmax
24	Warning: "Do not reach through the mast"
25	Serial number
26	Warning: "No passengers"
27	Model name
28	Test plaque
29	Data plate
30	Cold store truck reference

## 5.2 Data plate

- The illustration shows the standard version for EU member states. The data plate may differ in other countries.

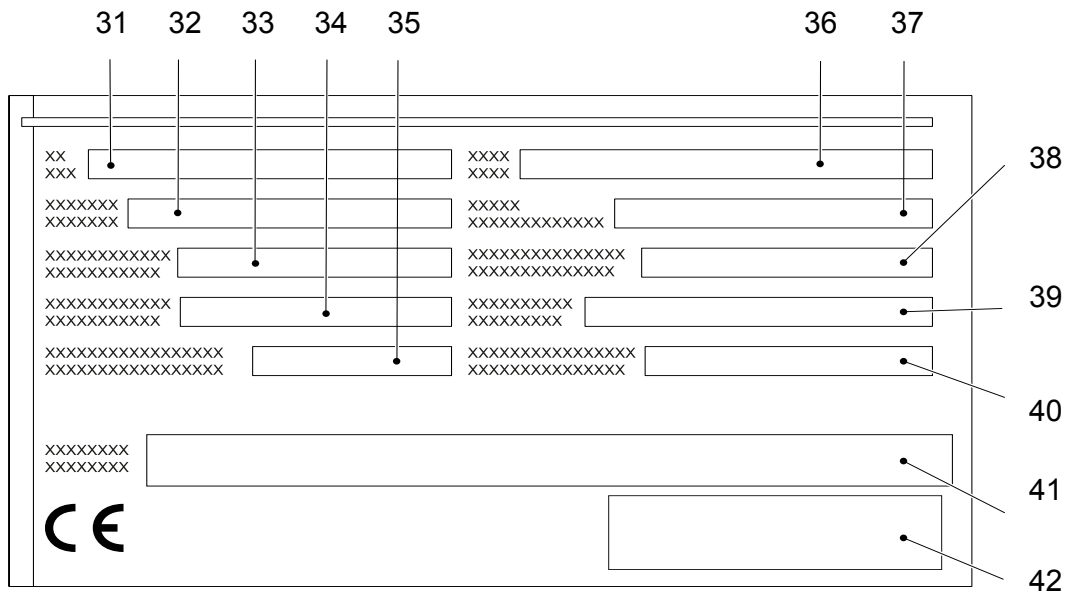

Item	Description	Item	Description
31	Type	37	Year of manufacture
32	Serial number	38	Load centre (mm)
33	Rated capacity (kg)	39	Output
34	Battery voltage (V)	40	Min./max. battery weight (kg)
35	Net weight w.o. battery (kg)	41	Manufacturer
36	Option	42	Manufacturer's logo

- For queries regarding the truck or ordering spare parts always quote the truck serial number (32).

## 5.3 Truck capacity plate

### Previous capacity plate

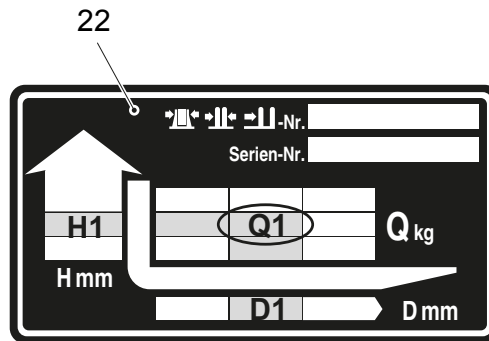

### Current capacity plate

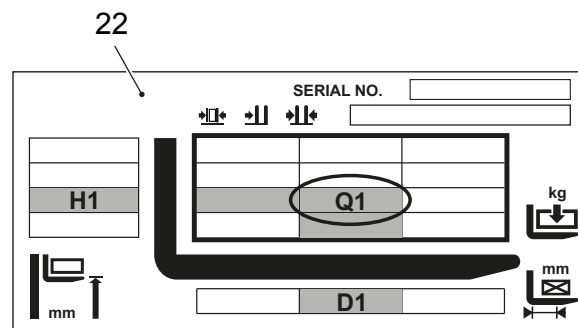

The rating plate (22) indicates the maximum capacity  $Q$  (in kg) for a given load centre  $C$  (in mm) and corresponding lift height  $H$  (in mm) for the truck with a horizontal load.

Example of how to calculate the maximum capacity:

At a load centre distance  $C1$  and a lift height  $H1$ , the maximum load capacity is  $Q1$

The arrow shaped markings on the outer mast (43) and on the inner mast (44) indicate to the operator when the height limits specified on the capacity plate have been exceeded.

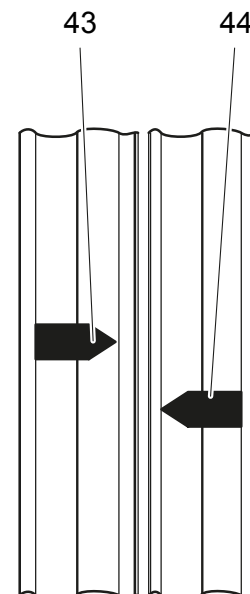

## 5.4 Wind loads

Wind forces can affect the stability of a truck when lifting, lowering and transporting loads with large surface areas.

Light loads must be especially secured when they are subjected to wind forces. This will prevent the load from sliding or falling.

Stop the truck in both cases.



## 5.5 Double Decker Mode Capacity Plate

The double decker mode capacity plate (23) indicates the capacity Q kg of the truck while travelling:

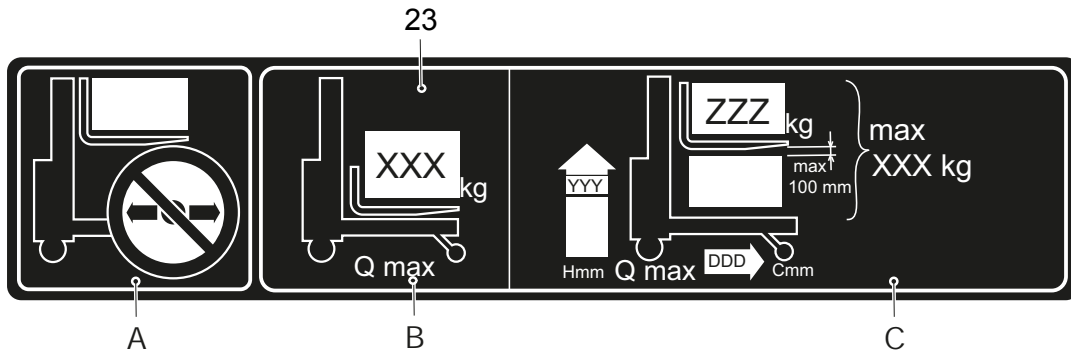

A=	No transporting with a raised load.
B=	Max. capacity for horizontal transporting XXX kg with raised support arms without mast lift.
C=	Double decker mode: Max. lift height YYY mm. Max. capacity for high level lifting according ZZZ. Max. capacity for both high and low level lifting XXX kg.

### CAUTION!

#### Risk to operational stability

In order not to jeopardize the operational stability, pay attention to the weight when transporting two pallets so that the truck does not tip over.

- In order not to jeopardize the operational stability, the heavier pallet should always be transported underneath.

# C Transport and Commissioning

## 1 Lifting by crane

### **WARNING!**

#### **All persons involved in loading by crane must be trained**

Incorrect crane loading procedures due to untrained personnel can cause the truck to fall. There is a risk of injury to personnel and a risk of material damage to the truck.

- ▶ Loading must only be performed by specialist personnel trained for this purpose. The specialist personnel must be instructed in securing loads on road vehicles and handling load securing devices. In each case correct measurements must be taken and appropriate safety measures applied.
- 

### **WARNING!**

#### **Incorrect lifting by crane can result in accidents**

Improper use or use of unsuitable lifting gear can cause the truck to fall when being lifted by crane.

Prevent the truck from hitting other objects during lifting, and avoid uncontrolled movements. If necessary, secure the truck with guide ropes.

- ▶ The truck should only be loaded by personnel trained in the use of lifting slings and tools.
  - ▶ Wear personal protective equipment (e. g. safety shoes, safety helmet, hi-vis jacket, protective gloves, etc.) when loading by crane.
  - ▶ Do not stand under suspended loads.
  - ▶ Do not enter or stand in a hazardous area.
  - ▶ Always use lifting gear with sufficient capacity (for truck weight see truck rating plate).
  - ▶ Always attach the crane lifting gear to the prescribed strap points and prevent them from slipping.
  - ▶ Use the lifting slings only in the prescribed loading direction.
  - ▶ Crane slings should be fastened in such a way that they do not come into contact with any attachments when lifting.
-

### ***Lifting the truck by crane***

#### ***Requirements***

- Park the truck securely, see "Parking the truck securely" on page 63.
- Remove any mast guards.

#### ***Tools and Material Required***

- Lifting gear
- Crane lifting gear

#### ***Procedure***

- Secure the lifting slings to the strap points (21).

*The truck can now be lifted by crane.*

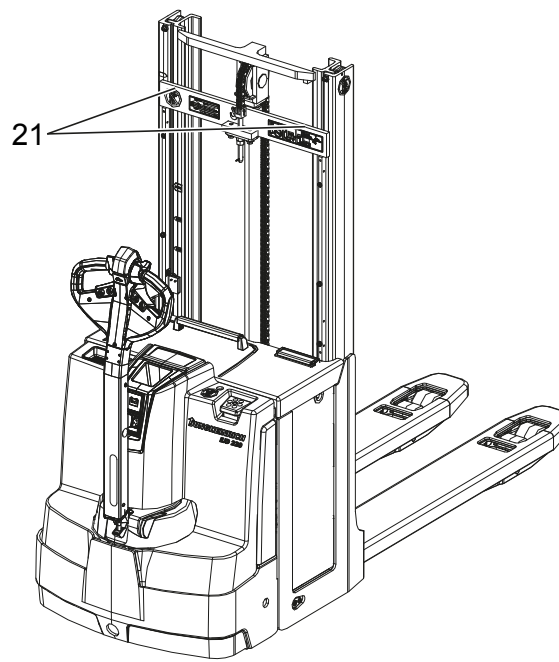

## 2 Transport

### **WARNING!**

#### **Accidental movement during transport**

Improper fastening of the truck and mast during transport can result in serious accidents.

- ▶ Loading must only be performed by specialist personnel trained for this purpose. The specialist personnel must be instructed in securing loads on road vehicles and handling load securing devices. In each case correct measurements must be taken and appropriate safety measures applied.
- ▶ The truck must be securely fastened when transported on a lorry or a trailer.
- ▶ The lorry or trailer must have fastening rings.
- ▶ Use wedges to prevent the truck from moving.
- ▶ Use only fastening belts with sufficient strength.
- ▶ Use non-slip materials to securing the load aids (pallet, wedges, ...) e. g. non-slip mats.

#### ***Securing the industrial truck for transport***

##### *Requirements*

- Load the truck.
- Park the truck securely, see "Parking the truck securely" on page 63.

##### *Tools and Material Required*

- Lashing straps

##### *Procedure*

- Attach the lashing straps (45) to the industrial truck and the transport vehicle and tension sufficiently.

*The truck can now be transported.*

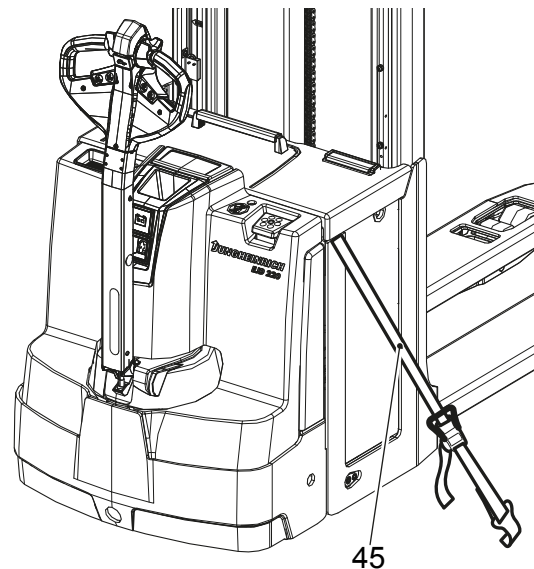

### 3 Using the Truck for the First Time

#### **WARNING!**

##### **The use of unsuitable energy sources can be hazardous**

Rectified AC current will damage the assemblies (controllers, sensors, motors etc.) of the electronic system.

Unsuitable cable connections (too long, insufficient wire cross-section) to the battery (tow cables) can overheat, setting the truck and battery on fire.

- ▶ The truck must only be operated with battery current.
- ▶ Cable connections to the battery (tow leads) must be less than 6 m long and have a minimum cross-section of 50 mm<sup>2</sup>.

---

#### *Procedure*

- Check the equipment is complete.
- If necessary, install the battery, see "Battery removal and installation" on page 49.
- Charge the battery, see "Charging the battery" on page 41.

*The truck can now be started, see "Preparing the Truck for Operation" on page 60.*

#### **NOTE**

Do not lift loads if the truck is operated via a tow lead with an external battery.

#### **NOTE**

##### **Cold store trucks**

- ▶ Trucks designed for use in cold stores have a cold store hydraulic oil and a protective frame instead of a mast guard on the mast.
- ▶ If a truck with cold store oil is used outside the cold store, the lowering speeds may increase.

---

#### **Wheel flattening**

If the truck has been parked for a long period, the wheel surfaces may tend to flatten. This flattening has a negative effect on the safety and stability of the truck. Once the truck has covered a certain distance, the flattening will disappear.

# D Battery - Servicing, Recharging, Replacement

## 1 Safety Regulations Governing the Handling of Lead-Acid Batteries

### Maintenance personnel

Batteries may only be charged, serviced or replaced by trained personnel. These operating instructions and the manufacturer's instructions concerning batteries and charging stations must be observed when carrying out the work.

### Fire Protection

Do not smoke and avoid naked flames when handling batteries. Wherever an industrial truck is parked for charging there must be no inflammable material or consumables capable of creating sparks within a minimum distance of 2 m from the truck. The room must be ventilated. Fire protection equipment must be available.

### CAUTION!

#### **The use of unsuitable fire protection equipment can result in scalding**

Extinguishing fires with water can cause a reaction with the battery acid. This can result in scalding from the acid.

- ▶ Use powder extinguishers.
  - ▶ Never extinguish a burning battery with water.
- 

### Battery maintenance

The battery cell covers must be kept dry and clean. The terminals and cable shoes must be clean, secure and have a light coating of dielectric grease.

### CAUTION!

#### **Short circuits can cause fires**

Damaged cables can cause a short circuit, setting the truck and the battery on fire.

- ▶ Before closing the battery cover make sure that the battery cables cannot be damaged.
- 

### Battery disposal

Batteries may only be disposed of in accordance with national environmental protection regulations or disposal laws. The manufacturer's disposal instructions must be observed.

 **WARNING!**

**Batteries can be hazardous**

Batteries contain an acid solution which is poisonous and corrosive. Avoid contact with battery acid at all times.

- ▶ Dispose of used battery acid in accordance with regulations.
  - ▶ Always wear protective clothing and goggles when working with batteries.
  - ▶ Do not let battery acid come into contact with skin, clothing or eyes. If necessary, rinse with plenty of clean water.
  - ▶ In the event of physical damage (e.g. skin or eye contact with battery acid) call for a doctor immediately.
  - ▶ Spilled battery acid should be neutralised immediately with plenty of water.
  - ▶ Only batteries with a sealed battery container may be used.
  - ▶ Follow national guidelines and legislation.
- 

 **WARNING!**

**Unsuitable batteries that have not been approved by Jungheinrich for the truck can be hazardous**

The design, weight and dimensions of the battery have a considerable effect on the operational safety of the truck, in particular its stability and capacity. The use of unsuitable batteries that have not been approved for the truck by Jungheinrich, can lead to a deterioration of the braking characteristics of the truck during energy recovery, causing considerable damage to the electric controller and resulting in serious danger to the health and safety of individuals.

- ▶ Only Jungheinrich-approved batteries may be used on the truck.
  - ▶ Battery equipment may only be replaced with the agreement of Jungheinrich.
  - ▶ When replacing/installing the battery make sure the battery is securely located in the battery compartment of the truck.
  - ▶ Do not use batteries that have not been approved by the manufacturer.
- 

Park the truck securely before carrying out any work on the batteries (see "Parking the truck securely" on page 63).

## 2 Battery types

Depending on the model, the truck will be supplied with different battery types. The following table shows which combinations are included as standard:

Battery type	Capacity (Ah)	Min. weight (kg)	Max. dimensions (mm)
24 volt battery	2 PzV 200	204	624X212X628
24 volt battery	2 PzS 250	204	624X212X628
24 volt battery	2 PzS 375	273	624X284X628
24 volt battery	3 PzV 300	273	624X284X628
24 volt battery	3 PzS 375 Lib. Silver	273	624X284X628
24 volt battery	2 PzS 250 Lib. Silver	204	624X212X628
24 volt battery	2 PzM 250	204	624X212X628
24 volt battery	3 PzM 375	273	624X284X628
24 volt battery	2 PzV 220	204	624X212X628
24 volt battery	3 PzV 330	273	624X284X686
24 volt battery	XFC 158	204	624X212X628
24 volt battery	XFC 316	273	624X284X628

The battery weights can be taken from the battery data plate. Batteries with non insulated terminals must be covered with a non slip insulating mat.



### 3 Exposing the battery

#### **WARNING!**

##### **An unsecured truck can cause accidents**

Parking the truck on an incline or with a raised load handler is dangerous and is strictly prohibited.

- ▶ Park the truck on a level surface. In special cases the truck may need to be secured with wedges.
- ▶ Fully lower the load handler.
- ▶ Select a place to park where no other people are at risk of injury from the lowered load handler.
- ▶ If the brakes are not working, place wedges underneath the wheels of the truck to prevent it from moving.

#### **CAUTION!**

##### **A closing battery panel can pose a trapping hazard**

If the battery cover is not opened fully, it can suddenly close on its own and cause bruising. The battery cover is only properly opened at an angle greater than 90°. It is then held by gravity.

- ▶ Open the battery cover as far as the stop.

##### *Requirements*

- Park the truck on a level surface.
- Park the truck securely, see "Parking the truck securely" on page 63.

##### *Procedure*

- Open the battery panel (7).
- Where necessary remove the insulating mat from the battery.

*The battery is now exposed.*

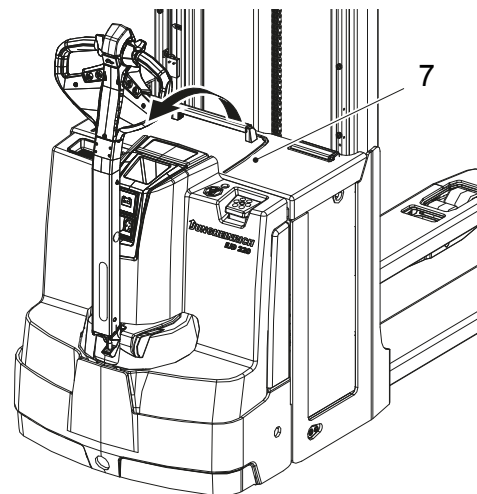

## 4 Charging the battery

### **WARNING!**

#### **The gases produced during charging can cause explosions**

The battery gives off a mixture of oxygen and hydrogen (electrolytic gas) during charging. Gassing is a chemical process. This gas mixture is highly explosive and must not be ignited.

- ▶ Switch the charging station and truck off first before connecting/disconnecting the charging cable of the battery charging station to/from the battery connector.
  - ▶ The charger must match the battery in terms of voltage, charge capacity and battery type.
  - ▶ Before charging, check all cables and plug connections for visible signs of damage.
  - ▶ Ventilate the room in which the truck is being charged.
  - ▶ The battery cover must be open and the battery cell surfaces must be exposed during charging to ensure adequate ventilation.
  - ▶ Do not smoke and avoid naked flames when handling batteries.
  - ▶ Wherever an industrial truck is parked for charging there must be no inflammable material or consumables capable of creating sparks within a minimum distance of 2 m from the truck.
  - ▶ Fire-control equipment must be available.
  - ▶ Do not place any metallic objects on the battery.
  - ▶ Always follow the safety regulations of the battery and charger station manufacturers.
- 

### **NOTE**

#### **Battery damage**

The battery, charger (charge characteristics) and battery parameters must match each other, otherwise damage may result.

---

## 4.1 Charging the battery with a stationary charger

### *Charging the battery*

#### *Requirements*

- Expose the battery, see "Exposing the battery" on page 40.

#### *Procedure*

- Disconnect the battery connector (46) from the truck connector.
- Connect the battery connector (46) to the charging cable (47) of the stationary charger.
- Start charging in accordance with the charger operating instructions.

*The battery is charging.*

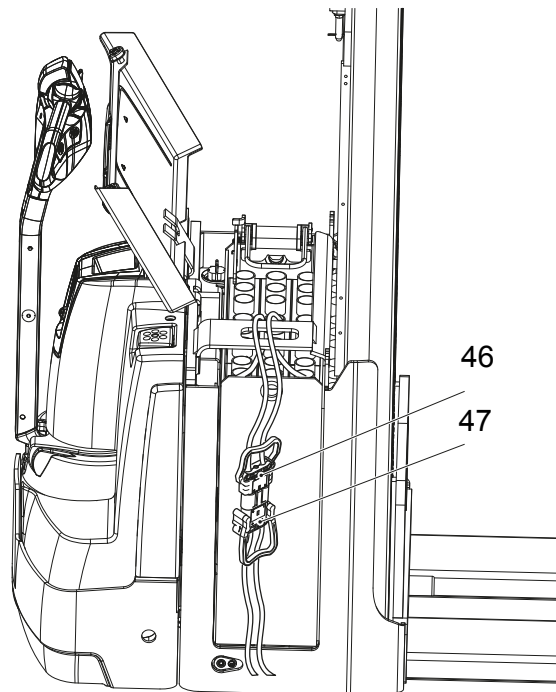

### *Completing battery charging, restoring the truck to operation*

#### **NOTE**

If charging has been interrupted, the full battery capacity will not be available.

#### *Requirements*

- The battery is fully charged.

#### *Procedure*

- Complete charging in accordance with the charger operating instructions.
- Disconnect the battery connector (46) from the charging cable (47) of the stationary charger.
- Attach the battery connector (46) to the industrial truck.

*The truck is now ready for operation.*

## 4.2 Charging the battery with an on-board charger (○)

### DANGER!

#### **Risk of electric shock and fire**

Damaged and unsuitable cables can cause electric shocks and can overheat, resulting in fires.

- ▶ Always use mains cables with a maximum length of 30 m.  
Local regulations must be observed.
  - ▶ Unwind the cable reel fully when using it.
  - ▶ Always use original manufacturer's mains cables.
  - ▶ Insulation safety, acid and caustic ratings must comply with the manufacturer's mains lead.
  - ▶ The charging connector must be dry and clean when used.
- 

### **NOTE**

#### **Improper use of the on-board charger can cause material damage**

The on-board charger consisting of a battery charger and battery controller must not be opened. If faulty, contact the manufacturer's customer service department.

- ▶ The charger must only be used for batteries supplied by Jungheinrich or other approved batteries provided it has been adapted by the manufacturer's customer service department.
  - ▶ Batteries must never be swapped from truck to truck.
  - ▶ Do not connect the battery to two chargers simultaneously.
-

#### 4.2.1 Setting the charging characteristics (ELG 2430)

- The factory setting for trucks without a battery is the 0 position. A battery discharge indicator, a charge/discharge indicator, a CanDis or a bipolar LED can be attached to the connector (49).

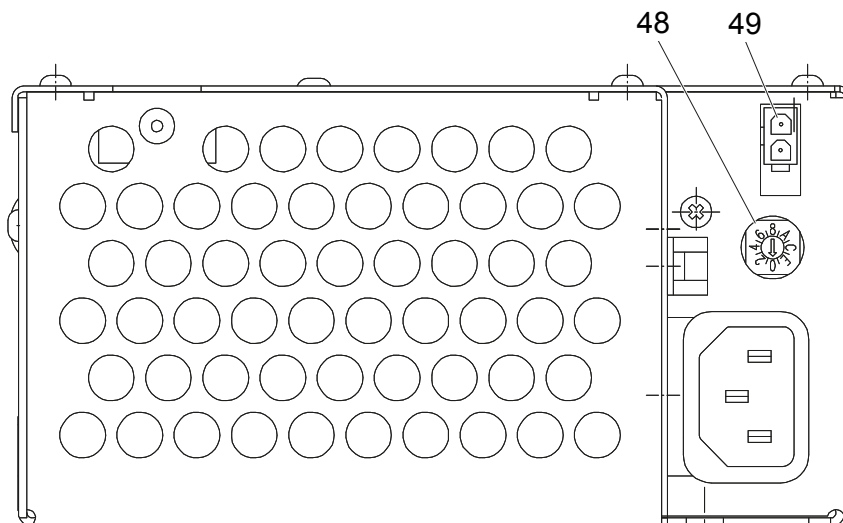

#### **⚠ CAUTION!**

- Remove the mains connector before setting the respective charging curve.

#### ***Set the charging characteristic***

##### *Requirements*

- Battery connected.

##### *Procedure*

- Turn the setting switch (48) on the charger right to adapt the charging curve to the battery being used.
- The validity of the new setting is acknowledged by the flashing of the green LED and the setting takes immediate effect.

*The charging characteristic is now set.*

Flashing sequence / charging curve assignment (ELG 2430)

Flashing sequence	Selected charging curves (characteristics)
0	Truck without battery
1	Wet cell battery: PzS with 100 - 300 Ah Wet cell battery: PzM with 100 - 179 Ah
2	Maintenance-free: PzV with 100 - 149 Ah
3	Maintenance-free: PzV with 150 - 199 Ah
4	Maintenance-free: PzV with 200 - 330 Ah
5	Wet cell battery: PzS with pulse characteristic 200 - 400 Ah Wet cell battery: PzM with pulse characteristic 180 - 400 Ah
6	Jungheinrich 100 - 300 Ah

**NOTE**

- ▶ All other switch positions (48) block the charger, and the battery is not charged.
- ▶ For PzM batteries with a capacity of less than 180 Ah set characteristic 1, beyond 180 Ah set characteristic 5.
- ▶ With PzS 200-300 Ah wet cell batteries both characteristic curves 1 and 5 can be used. Characteristic 5 achieves a faster charge.
- ▶ When the battery is connected this allows you to adjust via the charger: If the switch position is valid the green LED flashes according to the position set; if the switch position is invalid the red LED flashes.

## 4.2.2 Charging the battery

### Starting to charge with the on-board charger

#### – ELG mains connection

Mains supply: 230 V / 110 V (+10/-15%)

Mains frequency: 50 Hz / 60 Hz

The mains cable and mains connector (51) of the charger are contained in the battery compartment with their storage compartment (50).

### Charging the battery

#### Requirements

- Park the truck securely, see "Parking the truck securely" on page 63.
- Expose the battery, see "Exposing the battery" on page 40.
- Correct charging program set on charger.

#### Procedure

- Remove any insulating mats from the battery.
- The battery connector must remain plugged.
- Attach the mains connector (51) to a mains socket.
- Pull the Emergency Disconnect switch up.

The flashing LED indicates the charge status or a fault (for flashing codes see "LED Display" table).

*The battery is now charged.*

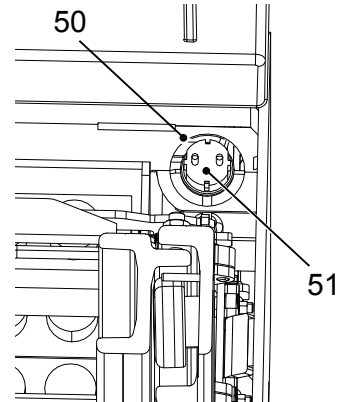

When the mains connector (51) is attached to the mains, all the truck's electrical functions are disconnected (electric immobilizer). The truck cannot be operated.

## ***Completing battery charging, restoring the truck to operation***

### **NOTE**

If charging has been interrupted, the full battery capacity will not be available.

---

#### *Requirements*

- The battery is fully charged.

#### *Procedure*

- Remove the mains connector (51) from the mains socket and store it along with the cable in the storage compartment (50).
- If applicable, place the existing insulating mats back over the battery.
- Close the battery panel securely.

*The truck is now ready for operation.*



### **CAUTION!**

#### **Damaged mains cables can be hazardous**

- ▶ Do not trap the mains cable when closing the battery panel.
- 

#### **Charging times**

The duration of charge depends on the battery capacity.



Charging continues automatically after a mains failure. Charging can be interrupted by removing the mains connector and continued as partial charging.



## LED display (52)

<b>Green LED (charge status)</b>	
Lit	Charging complete, battery full. (Charge interval, float or compensation charge).
Flashes slowly	Charging.
Rapid flash	Display at beginning of charge or after setting a new characteristic curve. Number of flash pulses corresponds to the characteristic curve set.

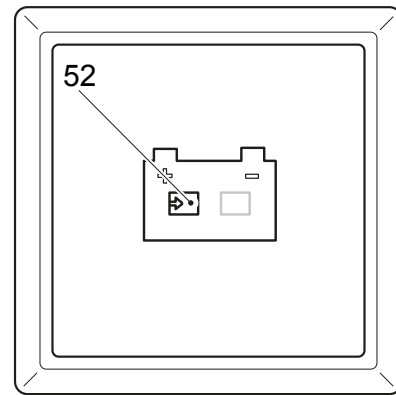

<b>Red LED (fault)</b>	
Lit	Overtemperature. Charging is interrupted.
Flashes slowly	Safety charging time exceeded. Charging is cancelled. Mains must be disconnected for charging to restart.
Rapid flash	Invalid characteristic curve setting.

### Compensation charge

The compensation charge starts automatically when charging is complete.

### Partial charging

The charger is designed to automatically adapt to partially charged batteries. This keeps battery wear to a minimum.

## 5 Battery removal and installation

### **WARNING!**

#### **Accident risk during battery removal and installation**

Due to the battery weight and acid there is a risk of trapping or scalding when the battery is removed and installed.

- ▶ Note the "Safety regulations for handling acid batteries" section in this chapter.
  - ▶ Wear safety shoes when removing and installing the battery.
  - ▶ Use only batteries with insulated cells and terminal connectors.
  - ▶ Park the truck on a level surface to prevent the battery from sliding out.
  - ▶ Make sure the crane slings have sufficient capacity to replace the battery.
  - ▶ Use only approved battery replacement devices (battery roller stand, replacement trolley etc.).
  - ▶ Make sure the battery is securely located in the truck's battery compartment.
- 

### **CAUTION!**

#### **Trapping hazard**

There is a risk of trapping when you close the battery cover.

- ▶ Make sure there is nothing between the battery cover and the truck when you close the battery cover.
-

## 5.1 Lateral battery removal

### CAUTION!

#### Trapping hazard

Trapping hazard when removing and installing the battery.

- ▶ When removing and installing the battery do not put your hands between the battery and the chassis.

#### Removing the battery

##### Requirements

- Truck parked securely, see "Parking the truck securely" on page 63
- The battery is exposed, see "Exposing the battery" on page 40

##### Procedure

- Disconnect the battery connector from the truck connector.
- Lift up the battery lock (53) as far as the stop.
- Pull the battery retaining lever / ejector (54) up and move the battery to the side.
- Pull the battery out from the side.

*The battery has now been removed.*

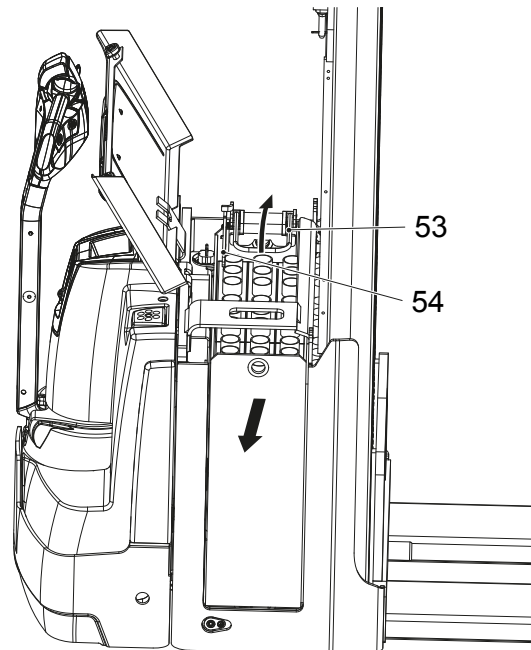

#### Battery installation

### NOTE

- ▶ Make sure the battery is installed and connected correctly.
- ▶ Place the battery cable on the tray so that it cannot be severed when the battery is inserted.

##### Procedure

- Insert the battery in the truck.
- Push the battery as far as the stop in the battery compartment.
- Raise the battery retaining lever (54) and pull the battery fully into the battery compartment.
- Turn the battery lock (53) down as far as the stop.

**⚠ CAUTION!**

**Unsecured battery**

Unsecured batteries can slide out of the battery tray.

► After installing the battery make sure the battery lock (53) is in place to prevent it from sliding out.

➔ After installing the battery again, check all cables and plug connections for visible signs of damage.

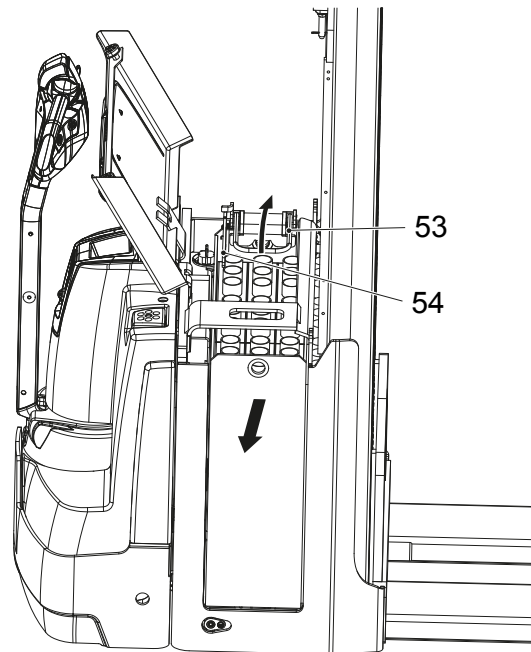



# E Operation

## 1 Safety Regulations for the Operation of the Forklift Truck

### **Driver authorisation**

The truck may only be used by suitably trained personnel, who have demonstrated to the proprietor or his representative that they can drive and handle loads and have been authorised to operate the truck by the proprietor or his representative.

### **Operator's rights, responsibilities and rules of conduct**

The driver must be informed of his duties and responsibilities and be instructed in the operation of the truck and shall be familiar with the operating instructions. Safety shoes must be worn on pedestrian-operated trucks.

### **Unauthorised use of truck**

The operator is responsible for the truck during the time it is in use. The operator must prevent unauthorised persons from driving or operating the truck. Do not carry passengers or lift other people.

### **Damage and faults**

The supervisor must be informed immediately of any damage or faults to the truck or attachment. Trucks which are unsafe for operation (e.g. wheel or brake problems) must not be used until they have been rectified.

### **Repairs**

The operator must not carry out any repairs or alterations to the truck without authorisation and the necessary training to do so. The operator must never disable or adjust safety mechanisms or switches.

## Hazardous area

### **WARNING!**

#### **Risk of accidents/injury in the hazardous area of the truck**

A hazardous area is defined as the area in which people are at risk due to travel or lifting operations of the truck, its load handler or the load. This also includes the area within reach of falling loads or lowering/falling operating equipment.

- ▶ Instruct unauthorised persons to leave the hazardous area.
  - ▶ In case of danger to third parties, give a warning signal in good time.
  - ▶ If unauthorised persons are still within the hazardous area, stop the truck immediately.
- 

#### **Safety devices, warning signs and warning instructions**

Safety devices, warning signs (see "Identification Points and Data Plates" on page 27) and warning instructions in the present operating instructions must be strictly observed.

### **WARNING!**

#### **Removing or disabling safety devices can cause accidents**

Removing or disabling safety devices such as the Emergency Disconnect switch, key switch, buttons, horn, strobe lights, mast protection pane, mast grille, sensors, panels etc. can result in accidents and injury.

- ▶ Report any defects immediately to your supervisor.
  - ▶ Mark defective truck and take out of service.
  - ▶ Do not return the industrial truck to service until you have identified and rectified the fault.
-

## 2 Displays and Controls

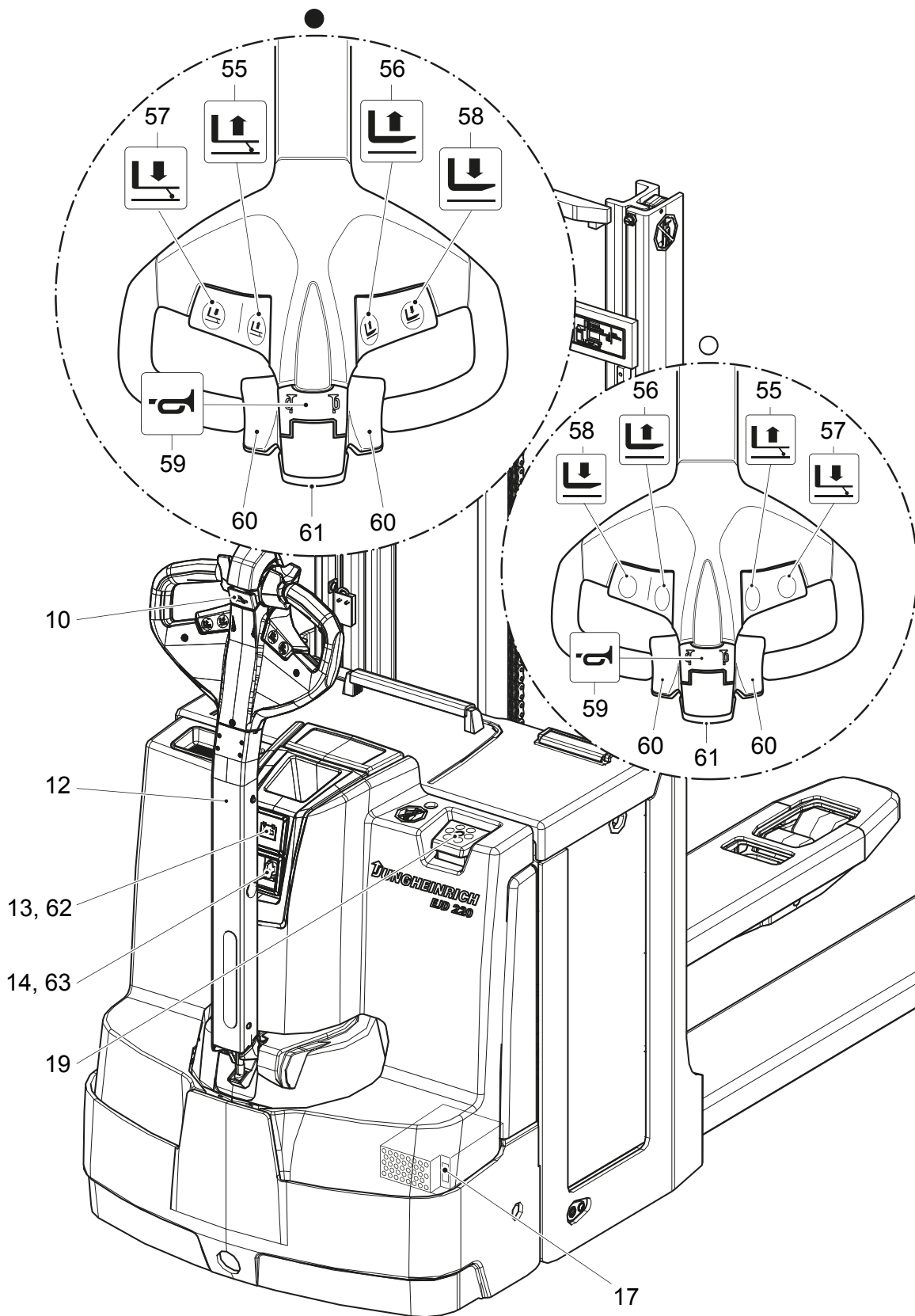



Item	Control /Display	EJD 220	Function
10	Slow travel button	●	Pressing the slow travel button reduces the travel speed and acceleration. If the tiller is in the brake zone, pressing this button overrides the braking function and the truck can be operated at slow speed.
12	Tiller	●	Used for steering and braking.
13	Charge / discharge indicator	●	Shows the charge/discharge status of the battery.
14	CanCode	○	Replaces the key switch <ul style="list-style-type: none"> <li>– Entering the code activates the truck</li> <li>– Travel program selection</li> <li>– Code setting</li> <li>– Parameter setting</li> </ul>
	ISM	○	Replaces the key switch <ul style="list-style-type: none"> <li>– Activates the truck via a card / transponder</li> <li>– Displays readiness for operation</li> <li>– Operational data logging</li> <li>– Data exchange with card / transponder</li> </ul>
17	On-board charger (with safety switch)	○	Charges the battery by inserting the mains connector into a mains socket.
19	Emergency disconnect switch	●	Disconnects the battery supply <ul style="list-style-type: none"> <li>– All electric functions are deactivated and the truck decelerates</li> </ul>
55	Wheel arm lift button	●	Lifts the wheel arms at a constant speed.
56	Fork lift button	●	Raises the forks. The lowering speed can be infinitely controlled by the stroke of the button (8 mm).
57	Wheel arm lower button	●	Lowers the wheel arms at a constant speed.
58	Fork lowering switch	●	Lowers the forks. The lowering speed can be infinitely controlled by the stroke of the button (8 mm).
59	Warning signal button (horn)	●	Sets off a warning signal.
60	Travel switch	●	Controls the travel direction and speed.

Item	Control /Display	EJD 220	Function
61	Collision safety switch	●	Safety feature – When applied the truck travels for approx. 3 seconds in the fork direction. The parking brake then applies. The truck remains switched off until the travel switch is returned to the neutral position.
62	CanDis	○	Display instrument for – Battery charge status – Service hours – Warning messages – Parameter setting
63	Key switch	●	– Activates the truck by applying the control voltage – Removing the key prevents the truck from being switched on by unauthorised personnel
	Key switch with second switch level	○	Brake release to move the truck when non-operational.
● = Standard equipment		○ = Optional equipment	

## 2.1 Battery discharge monitor

- The standard setting for the battery discharge indicator / discharge monitor is based on standard batteries. When using maintenance-free or special batteries, the display and cut-out points of the battery discharge monitor must be set by manufacturer's service department. If this adjustment is not made, the battery may become damaged due to deep discharge.

### NOTE

#### **Full discharge can damage the battery**

Self-discharge can cause the battery to fully discharge. Full discharge shortens the useful life of the battery.

- Charge the battery at least every 2 months.
- 

- Charge the battery see page 41.

If the residual capacity falls below the required level, lifting is inhibited. An alternating display (64) appears. Lifting is only released when the battery connected is at least 70% charged.

## 2.2 Battery discharge indicator

When the truck has been released via the key switch, CanCode or ISM, the battery charge status is displayed. The LED colours (64) represent the following conditions:

LED colour	Charge status
Green	40–100%
Orange	30–40%
Green/orange flashes at 1 Hz	20–30%
Red	0–20%

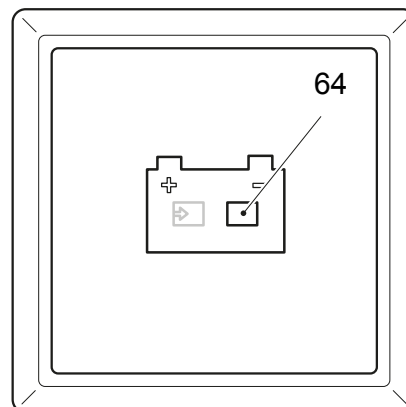

If the LED is red, the load can no longer be lifted. Lifting is only enabled when the battery connected is at least 70% charged.

If the LED flashes red and the truck is not ready for operation, inform the manufacturer's service department. Red flashing is a truck controller code. The flashing sequence indicates the type of fault.

## 3 Preparing the Truck for Operation

### 3.1 Checks and Operations to Be Performed Before Starting Daily Work

#### **WARNING!**

**Damage and other truck or attachment (optional equipment) defects can result in accidents.**

If damage or other truck or attachment (optional equipment) defects are discovered during the following checks, the truck must be taken out of service until it has been repaired.

- ▶ Report any defects immediately to your supervisor.
- ▶ Mark defective truck and take out of service.
- ▶ Do not return the industrial truck to service until you have identified and rectified the fault.

---

#### ***Inspection before daily operation***

##### *Procedure*

- Check the whole of the outside of the truck for signs of damage and leaks. Damaged hoses must be replaced immediately.
- Check the battery attachment and wire connections for damage and make sure they are secure.
- Check the battery connectors are secure.
- Check the load handler for visible signs of damage such as cracks, bent or severe wear.
- Check the drive wheel and load wheels for damage.
- Check that the markings and labels are present, clean and legible, see "Identification Points and Data Plates" on page 27.
- Check the protection screen / grille and their attachments are secure and undamaged.
- Make sure the drive panels and covers are secure and check for damage.
- Check the steering play.
- With the load handler lowered, check the mast chains are tensioned and secured correctly.

## 3.2 Preparing the truck for operation

### Switching on the truck

#### Requirements

- For checks and operations to be performed before starting daily operation, see "Checks and Operations to Be Performed Before Starting Daily Work" on page 60.

#### Procedure

- Pull the Emergency Disconnect (19) to switch it on.
- Switch on the truck, to do this
  - Insert the key in the key switch (63) and turn it as far right as it will go.
  - Enter the code in the code lock (○).
  - Hold the card or transponder in front of the ISM access module and depending on the setting press the green button on the ISM access module (○).
- Test the warning signal button (59).
- Test the lifting operation.
- Test the steering.
- Test the brake function of the tiller (12).

*The truck is now ready for operation.*

● The battery discharge indicator (13) shows the current battery charge status.

○ The CanDis display instrument (62) indicates the available battery capacity and the service hours.

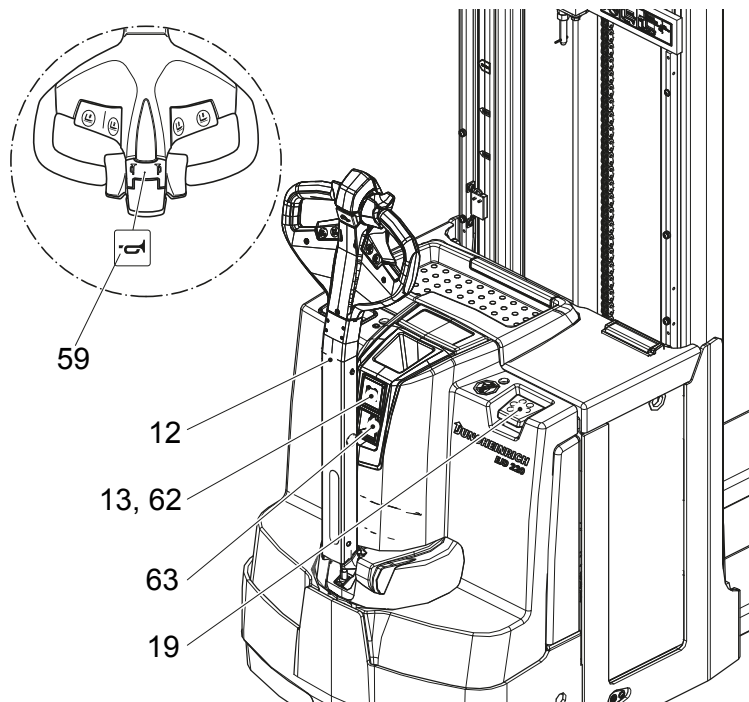

### 3.3 Checks and operations to be carried out when the truck is operational

#### **WARNING!**

#### **Risk of accident due to damage to or other defects in the truck and optional features**

If damage or other truck or attachment (optional equipment) defects are discovered during the following checks, the truck must be taken out of service until it has been repaired.

- ▶ Report any defects immediately to your supervisor.
- ▶ Mark defective truck and take out of service.
- ▶ Do not return the industrial truck to service until you have identified and rectified the fault.

---

#### *Procedure*

- Test warning indicators and safety devices:
  - Test the emergency disconnect function by pressing the emergency disconnect switch. The main circuit is disconnected and no truck operations can be performed. Now pull the Emergency Disconnect switch to unlock it.
  - Test the horn by pressing the "warning signal" button.
  - Check braking efficiency, see "Brakes" on page 73.
  - Test the steering, see "Steering" on page 72.
  - Test the hydraulic system, see "Load handler raise/lower" on page 75.
  - Test travel operations, see "Travel" on page 69.
  - Test the "collision safety switch" by depressing it whilst driving in the drive direction.
- Test the controls and displays and check for damage, see "Displays and Controls" on page 55.
  - Check tiller return function.
  - Check the controls automatically return to the neutral position after use.

## 3.4 Parking the truck securely

### **WARNING!**

#### **An unsecured truck can cause accidents**

Do not park the truck on an incline. Do not park the truck without the brakes engaged or with a raised load handler.

- ▶ Park the truck on a level surface. In special cases the truck may need to be secured with wedges.
  - ▶ Fully lower the load handler.
  - ▶ Select a place to park where no other people are at risk of injury from the lowered load handler.
  - ▶ If the brakes are not working, place wedges underneath the wheels of the truck to prevent it from moving.
- 

#### ***Park the truck securely***

##### *Procedure*

- Park the truck on a level surface.
- Fully lower the load handler (54):
  - Press the lower button (58).
- Using the tiller (12) set the drive wheel to the straight ahead position.
- Switch off the truck, to do this:
  - Turn the key in the key switch (2) anti-clockwise as far as it will go. Remove the key from the key switch (2).
  - For CanCode (14) press the O key (○).
  - Press the red button on the ISM access module (○).
- Press the Emergency Disconnect (19).

*The truck is parked.*



## 4 Industrial Truck Operation

### 4.1 Safety regulations for truck operation

#### Travel routes and work areas

Only use lanes and routes specifically designated for truck traffic. Unauthorised third parties must stay away from work areas. Loads must only be stored in places specially designated for this purpose.

The truck must only be operated in work areas with sufficient lighting to avoid danger to personnel and materials. Additional equipment is necessary to operate the truck in areas of insufficient lighting.

#### **WARNING!**

Do not exceed the permissible surface and spot load limits on the travel routes. At blind spots get a second person to assist.

---

#### Travel conduct

The operator must adapt the travel speed to local conditions. The truck must be driven at slow speed when negotiating bends or narrow passageways, when passing through swing doors and at blind spots. The operator must always observe an adequate braking distance between the forklift truck and the vehicle in front and must be in control of the truck at all times. Abrupt stopping (except in emergencies), rapid U turns and overtaking at dangerous or blind spots are not permitted. Do not lean out or reach beyond the working and operating area.

#### Travel visibility

The operator must look in the direction of travel and must always have a clear view of the route ahead. If the truck is carrying loads that affect visibility, the truck must travel against the load direction. If this is not possible, a second person must walk alongside the truck as a lookout to observe the travel route while maintaining eye contact with the operator. Proceed only at walking pace and with particular care. Stop the truck as soon as you lose eye contact.

## Negotiating slopes and inclines

Negotiating slopes and inclines up to 15 % is only permitted when they are recognised lanes. The slopes and inclines must be clean, have a non-slip surface, and negotiating them safely must be within the technical specifications of the truck. The truck must always be driven with the load facing uphill. The industrial truck must not be turned, operated at an angle or parked on inclines or slopes. Inclines must only be negotiated at slow speed, with the driver ready to brake at any moment.

## Negotiating lifts, loading ramps and docks

Lifts may only be negotiated if they have sufficient capacity, are suitable for driving on and authorised for truck traffic by the owner. The driver must satisfy himself of the above before entering these areas. The truck must enter lifts with the load in front and must take up a position which does not allow it to come into contact with the walls of the lift shaft. Persons riding in the lift with the forklift truck must only enter the lift after the truck has come to a rest and must leave the lift before the truck. The driver must ensure that the loading ramp / dock cannot move or come loose during loading / unloading.

## Type of loads to be carried

The operator must make sure that the load is in a satisfactory condition. Loads must always be positioned safely and carefully. Use suitable precautions to prevent parts of the load from tipping or falling down. Prevent liquid loads from sloshing out.



### **WARNING!**

## Electromagnetic influence can result in accidents

Strong magnets can cause electronic components such as Hall sensors to become damaged, resulting in accidents.

- ▶ Do not use magnets in the operating area of the truck. Exceptions to this rule are commercial, weak clamping magnets for attaching notices.
-

## 4.2 Emergency Disconnect

### CAUTION!

#### **Applying maximum braking can result in accidents**

Applying the Emergency Disconnect switch during travel will cause the truck to decelerate to a halt at maximum force. This may cause the load to slide off the load handler. There is a higher risk of accidents and injury.

- ▶ Do not use the Emergency Disconnect switch as a service brake.
  - ▶ Use the Emergency Disconnect switch during travel only in emergencies.
- 

### CAUTION!

#### **Faulty or non-accessible Emergency Disconnect switches can cause accidents**

A faulty or non-accessible Emergency Disconnect switch can cause accidents. In dangerous situations the operator cannot bring the truck to a halt in time by applying the Emergency Disconnect switch.

- ▶ The operation of the Emergency Disconnect switch must not be affected by any objects placed in its way.
  - ▶ Report any defects on the Emergency Disconnect switch immediately to your supervisor.
  - ▶ Mark defective truck and take out of service.
  - ▶ Do not return the industrial truck to service until you have identified and rectified the fault.
-

### **Press the Emergency Disconnect switch**

#### *Procedure*

- Press the Emergency Disconnect (19).

*All electrical functions are deactivated. The truck brakes to a halt.*

- Press the Emergency Disconnect switch on in emergencies.

### **Releasing the Emergency Disconnect switch**

#### *Procedure*

- Pull the Emergency Disconnect switch (19) to unlock it.

*All electrical functions are enabled and the truck is operational again (provided the truck was operational before the Emergency Disconnect was pressed).*

- Trucks with CanCode and ISM access module remain switched off.

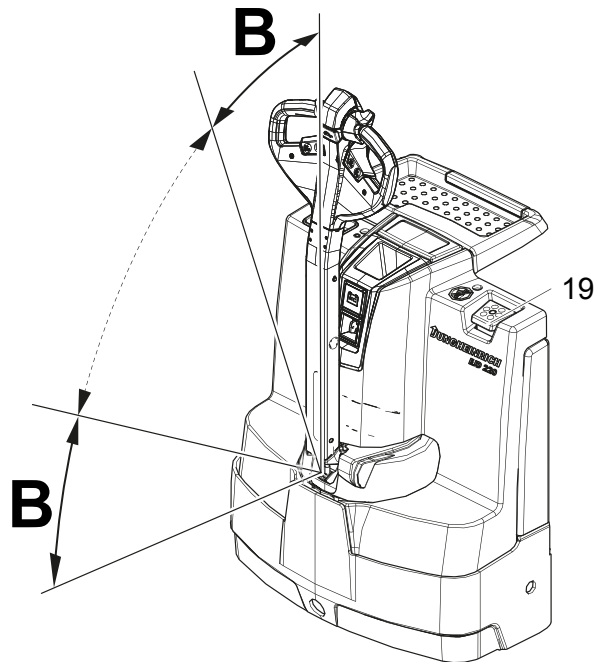

### 4.3 Automatic braking



When the tiller is released, it returns automatically to the upper brake zone (B) and the brakes are applied automatically.



#### **WARNING!**

##### **Risk of collision due to a defective tiller**

Operating the truck with a defective tiller can lead to collisions with persons or objects.

- ▶ If the tiller returns to the brake position slowly or not at all, the truck must be taken out of service until the cause of this fault is be rectified.
  - ▶ Contact the manufacturer's customer service department.
-

## 4.4 Travel

### **WARNING!**

#### **Collision hazard when operating the truck**

Collisions with personnel and equipment can result if the truck is operated with open panels.

- ▶ Do not operate the truck unless the panels and covers are closed and properly locked.
  - ▶ When travelling through swing doors etc. make sure that the doors do not activate the collision safety button.
- 

#### *Requirements*

- Start up the truck, see "Preparing the Truck for Operation" on page 60.

#### *Procedure*

- Set the tiller (12) to the travel zone (F).
  - Control the travel direction with the travel switch (9):
    - Rotate the travel switch (9) slowly in the load direction (3):  
Travel in load direction:
    - Rotate the travel switch (9) slowly in the drive direction (2):  
Travel in drive direction:
  - Control the travel speed with the travel switch (9):
    - The further the travel switch (9) is rotated, the greater the travel speed.
  - Control the travel speed by rotating the travel switch (9) further or less.
-  After releasing the travel switch (9), it automatically returns to the neutral position (0), and the truck brakes.

*The brakes are released and the truck moves in the selected direction.*

#### **Anti-roll back device for slow travel on inclines**

If the truck does not have sufficient speed to travel up an incline, it may roll back. Rolling back is detected by the truck's controller and the truck brakes to a halt immediately.

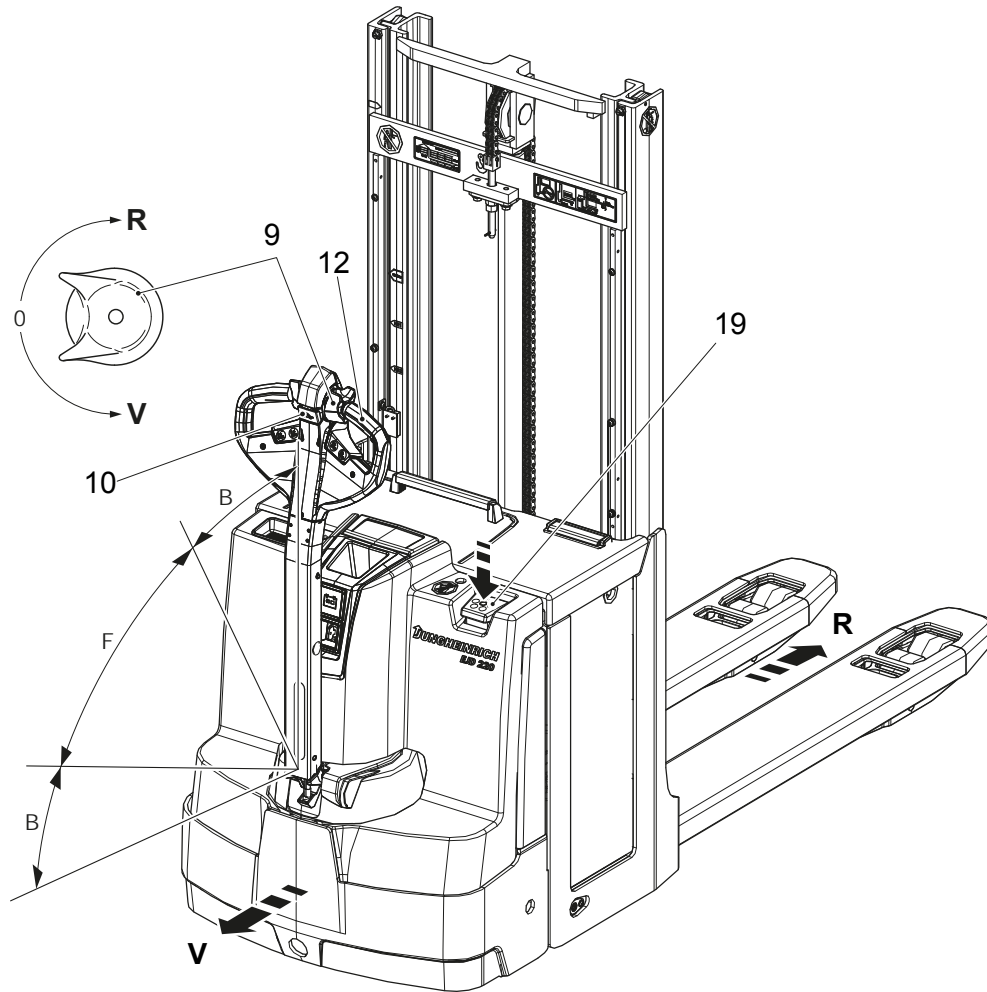

○ **Reduced speed when the load handler is fully lowered!**

When the load handler is fully lowered the truck can only travel at reduced speed. The load handler must be raised in order to use the maximum available speed.

#### 4.4.1 Changing direction during travel

##### CAUTION!

##### **Danger when changing direction during travel**

Changing direction during travel causes the truck to decelerate sharply. When the truck changes direction, it can start travelling at high speed in the opposite direction unless the travel switch is released in time.

- ▶ After setting off in the opposite direction, apply the travel switch gently or not at all.
  - ▶ Do not perform any sudden steering operations.
  - ▶ Always face in the direction of travel.
  - ▶ Maintain an adequate overview of the route you are travelling.
- 

##### ***Changing direction during travel***

##### *Procedure*

- Set the travel switch (9) to the opposite direction while travelling.

*The truck decelerates until it starts to travel in the opposite direction.*



## 4.5 Slow travel

### CAUTION!

#### **Risk of accident if the service brake is deactivated**

Particular care and attention is required by the operator during slow travel. The service brake is deactivated during slow travel and is only reactivated after the "slow travel" button is released.

- ▶ In hazardous situations brake by immediately releasing the "slow travel" button and the travel switch.
- ▶ During slow travel you can only brake by coating braking.

 The truck can be operated with an upright tiller (12) (e. g. in confined spaces / elevators).

#### **Switch on the slow travel function**

##### *Procedure*

- Press and hold down the "slow travel" button (10).
- Rotate the travel switch (9) in the required travel direction.

*The brake is released. The truck travels at slow speed.*

#### **Switching off slow travel**

##### *Procedure*

- Release the "slow travel" button (10).  
*If the tiller is in brake zone "B", the brake applies and the truck stops.*  
*If the tiller is in brake zone "F" the truck continues at slow travel speed.*
- Release the travel switch (9).

*Slow travel ends and the truck can now travel again at normal speed.*

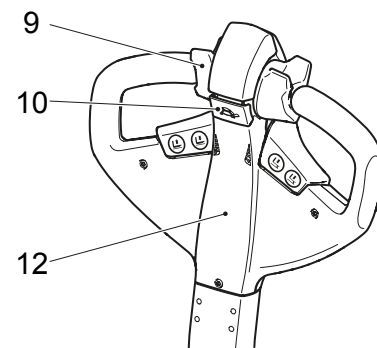

## 4.6 Steering

##### *Procedure*

- Move the tiller (12) to the left or right.

*The truck is steered in the required direction.*

## 4.7 Brakes

### **WARNING!**

#### **Accident risk while braking**

The truck's braking response depends largely on the floor condition and the type of surface. The truck's braking distance increases when the ground is wet or dirty.

- ▶ The operator must be aware of floor conditions and take them into account when braking.
  - ▶ Brake with care to prevent the load from slipping.
- 

The truck can brake in three different ways:

- By using the service brake (brake zone B).
- By regenerative braking (coasting brake).
- By inversion braking (braking and changing direction).

### **CAUTION!**

- ▶ In hazardous situations set the tiller to the brake position or press the Emergency Disconnect switch.
- 

### 4.7.1 Braking with the service brake

#### *Procedure*

- Move the tiller (12) up or down to one of the brake zones (B).

*The truck decelerates at the maximum rate until it comes to a halt.*

### 4.7.2 Inversion braking

#### *Procedure*

- Set the travel switch (9) to the opposite direction while travelling, see "Changing direction during travel" on page 71.

*The truck brakes regeneratively until it starts to move in the opposite direction.*

### 4.7.3 Regenerative braking

#### *Procedure*

- If the travel switch (9) is set to (0), the truck automatically brakes regeneratively.

*The truck brakes to a halt regeneratively via the coasting brake.*



*When braking regeneratively, energy is returned to the battery, ensuring a longer service time.*

### 4.7.4 Inversion braking

#### *Procedure*

- Set the travel switch (9) to the opposite direction while travelling, see "Changing direction during travel" on page 71.

The truck brakes regeneratively until it starts to move in the opposite direction.

#### 4.7.5 Parking brake

→ The mechanical brake applies automatically when the truck comes to rest.

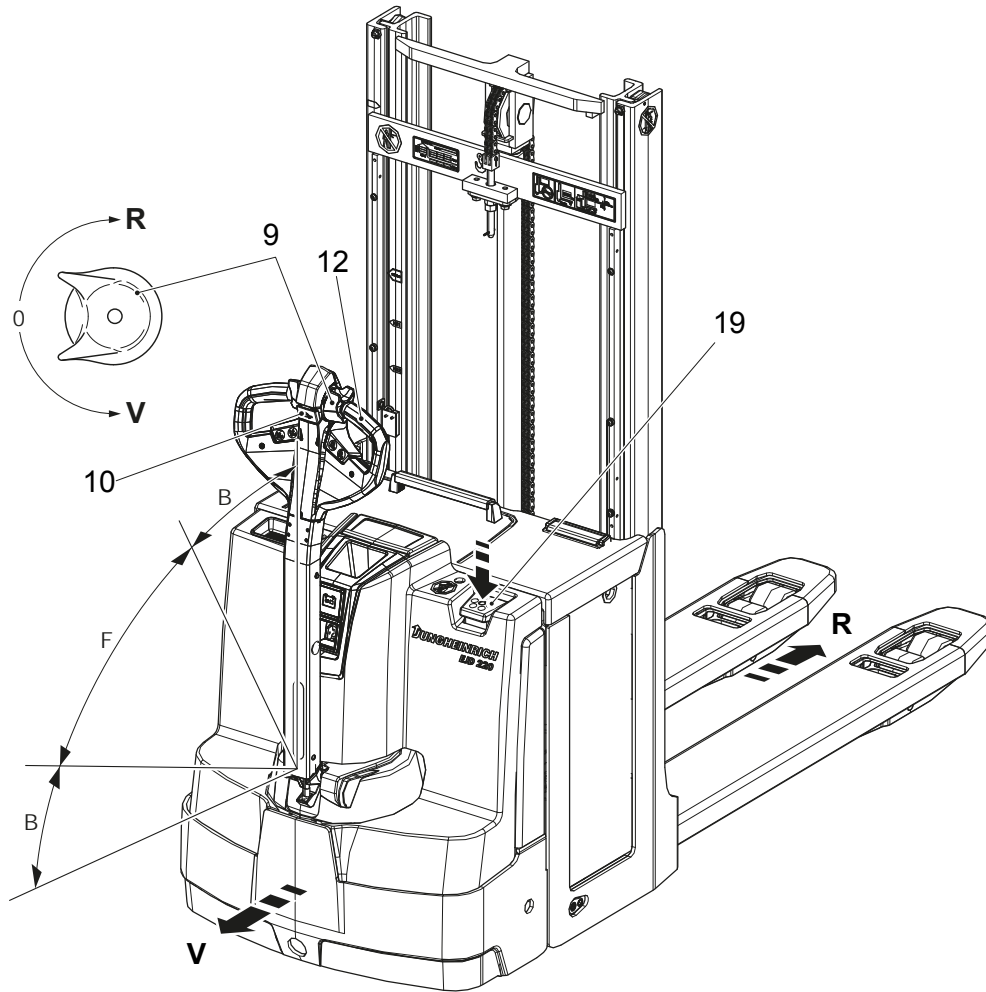

## 4.8 Load handler raise/lower

### **WARNING!**

#### **Accident risk when lifting and lowering**

Other people can be injured in the truck's hazardous area.

The hazardous area is defined as the area in which people are at risk from the movement of the truck including the load handler, etc. This also includes areas which can be reached by falling loads, operating equipment, etc.

Apart from the driver (in the normal operating position) there should be no other people in the truck's hazardous area.

- ▶ Instruct other people to move out of the hazardous area of the truck. Stop working with the truck if people do not leave the hazardous area.
- ▶ If people do not leave the hazardous area despite the warning, prevent the truck from being used by unauthorised people.
- ▶ Only carry loads that have been secured and positioned in accordance with regulations. Use suitable precautions to prevent parts of the load from tipping or falling down.
- ▶ Never exceed the maximum loads specified on the capacity plate.
- ▶ Never stand underneath a raised load handler.
- ▶ Do not stand on the load handler.
- ▶ Do not lift other people on the load handler.
- ▶ Never reach or climb into moving truck parts.
- ▶ Do not climb onto parts of the building or other trucks.

### **NOTE**

Adapt a slower speed when stacking and retrieving.



Hydraulic function lock: The new software version (from February 2014) has a presetting that only enables lifting when the tiller is in the travel range (F) or when the "slow travel" button is pressed. This does not affect lowering. The presetting can be changed via a parameter, see page 118.

## 4.8.1 Raising the load handler

### Requirements

- Prepare the truck for operation, see page 61.

### Procedure

- Press the “Raise load handler” button (56) until you reach the desired lift height.

### NOTE

#### Risk of material damage to the hydraulic unit

When you have reached the mechanical stops of the load handler, do not press the “Raise load handler” button any more. Otherwise the hydraulic unit could suffer material damage.

- The lift/lower speed can be infinitely controlled via the movement of the button (approx. 8 mm).  
Short stroke = slow lift / lower  
Long stroke = fast lift / lower

*The load handler is raised.*

### Tiller from above

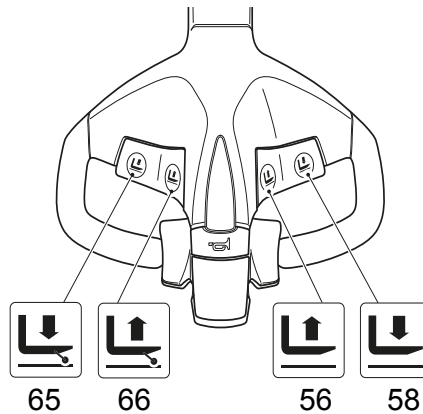

### Tiller from below

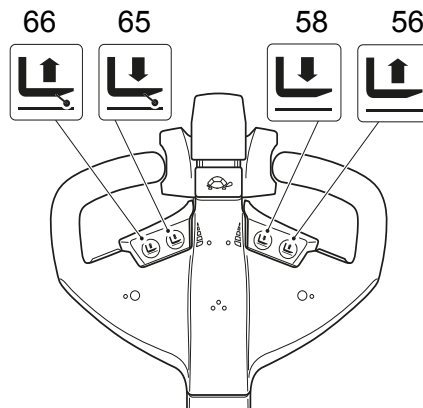

#### 4.8.2 Lowering the load handler

##### *Requirements*

- Prepare the truck for operation, see "Preparing the truck for operation" on page 61.

##### *Procedure*

- Press the "Lower load handler" button (58) until you reach the desired lift height.  
→ The lift/lower speed can be infinitely controlled via the movement of the button (approx. 8 mm).  
Short stroke = slow lift / lower  
Long stroke = fast lift / lower

*The load handler is lowered.*

#### 4.8.3 Raising the wheel arms

##### *Requirements*

- Prepare the truck for operation, see "Preparing the truck for operation" on page 61.

##### *Procedure*

- Press the "wheel arm raise" button (66) until you reach the desired wheel arm lift.

*The wheel arms are raised.*

#### 4.8.4 Lowering the wheel arms

##### *Requirements*

- Prepare the truck for operation, see "Preparing the truck for operation" on page 61.

##### *Procedure*

- Press the "wheel arm lower" button (65) until you reach the desired wheel arm lift.

*The wheel arms are lowered.*

## 4.9 Lifting, transporting and depositing loads

### **WARNING!**

#### **Unsecured and incorrectly positioned loads can cause accidents.**

Before lifting a load unit, the driver must make sure that it has been correctly palletised and does not exceed the truck's capacity.

- ▶ Instruct other people to move out of the hazardous area of the truck. Stop working with the truck if people do not leave the hazardous area.
  - ▶ Only carry loads that have been correctly secured and positioned. Use suitable precautions to prevent parts of the load from tipping over or falling off the truck.
  - ▶ Damaged loads must not be transported.
  - ▶ Never exceed the maximum loads specified on the load diagram.
  - ▶ Never stand underneath a raised load handler.
  - ▶ Do not stand on the load handler.
  - ▶ Do not lift other people on the load handler.
  - ▶ Insert the load handler as far as possible underneath the load.
- 

### **CAUTION!**

- ▶ Do not lift long loads at an angle.
- 

### **NOTE**

With the two-stage Duplex mast (ZZ) and the three-stage Triplex mast (DZ) a short, centre-mounted free lift cylinder initially lifts the load carriage (free lift) without changing the overall height of the truck. From a truck-specific lift height, travel is automatically reduced. It increases again when the load is lowered.

---

### **NOTE**

Beyond a lift height of > 1800 mm the travel speed is reduced to 2.5 km/h. The truck's acceleration is reduced from a 1800 mm lift height.

---

## 4.9.1 Raising a load

### Requirements

- Load correctly palletised.
- Load weight matches the truck's capacity.
- Load handler evenly loaded for heavy loads.

### Procedure

- Drive the truck carefully up to the pallet.
  - Drive the load handler slowly into the pallet until the pallet is against the back of the load handler (see graphic to the right).
- The load must not extend by more than 50 mm beyond the load handler tips.
- Raise the load handler until the desired height is reached, (see page 76).

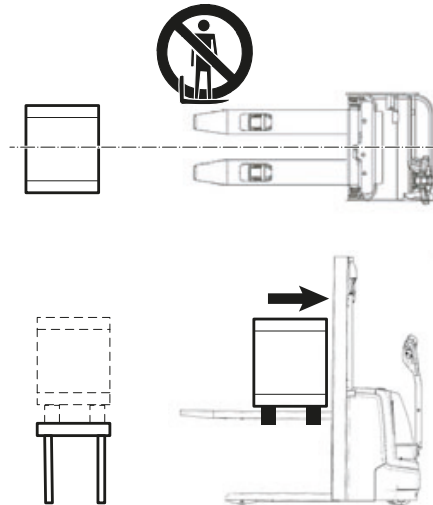

*The load is being raised.*

### NOTE

#### Risk of material damage to the hydraulic unit

When the mechanical stops of the load handler have been reached, release the "raise load handler" button. Otherwise the hydraulic unit may suffer material damage.

- The lifting/lowering speed can be infinitely controlled via the movement of the button (approx. 8 mm).

Short stroke = slow lift / lower

Long stroke = fast lift / lower

- Lifting two palletised loads on top of each other see page 82.



## 4.9.2 Transporting loads

### *Requirements*

- Load raised correctly.
- Mast lowered for proper transport (approx. 150 - 500 mm above the ground). Do not travel with a raised load (>500 mm).  
In double decker mode: Load handler lowered as far as possible but without touching the lower load, see page 84.
- Good ground conditions.

### *Procedure*

- Accelerate and decelerate with care.
- Adapt your travel speed to the conditions of the route and the load you are transporting.
- Travel at a constant speed.
- Be prepared to brake at all times.
  - Brake gently in normal circumstances.
  - Only stop suddenly in dangerous situations.
- Watch out for other traffic at crossings and passageways.
- Always travel with a lookout at blind spots.
- Do not travel across or at an angle on inclines. Do not turn on slopes and inclines, and always drive with the load facing uphill (see graphic).

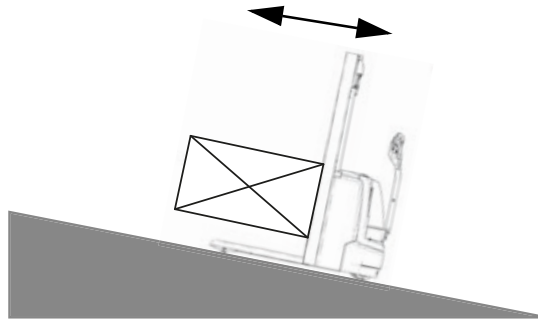

→ Transporting two palletised loads on top of each other see page 84.

### 4.9.3 Depositing a load

#### CAUTION!

Loads must not be set down on transport or escape routes, in front of safety installations or factory equipment that must be accessible at all times.

---

#### *Requirements*

- Storage location suitable for storing the load.

#### *Procedure*

- Drive the truck carefully up to the storage location.
- Lowers the load handler.
-  To avoid damaging the load and the load handler, avoid setting the load down abruptly.
- Lower the load handler so that it is clear of the load (see page 77).
- Carefully drive the load handler out from beneath the pallet.

*The load is deposited.*

#### NOTE



Avoid depositing the load suddenly to avoid damaging the load, load handler and the rack.

---

#### NOTE

The "soft landing" feature reduces the lowering speed of the load just before it reaches the ground (approx. 100-300 mm).

---

-  The "soft landing" feature is an optional extra.
-  Depositing two palletised loads on top of each other see page 85.

#### 4.9.4 Lifting two palletised loads

### CAUTION!

#### Risk to operational stability

In order not to jeopardize the operational stability, pay attention to the weight when transporting two pallets so that the truck does not tip over.

► In order not to jeopardize the operational stability, the heavier pallet should always be transported underneath.

#### Requirements

- Load correctly palletised.
- Load weight matches the truck's capacity.
- Load handler evenly laden for heavy loads.

#### Procedure

- Drive the truck carefully up to the pallet.
- Insert the load handler slowly into the first pallet until the pallet is resting against the back of the load handler (see right-hand graphic).



The load must not extend by more than 50 mm beyond the load handler tips.

- Raise the load handler until you reach the desired height, (see page 76).
- Insert the support arms under the second pallet.



The bottom load must be heavier than the top in double decker mode.

- Raise the support arms with the "Support arm lift" button.

*Both pallets are raised.*



When transporting, the load handler with the upper load must be lowered as near as possible to the lower load, however not on top of the lower load.

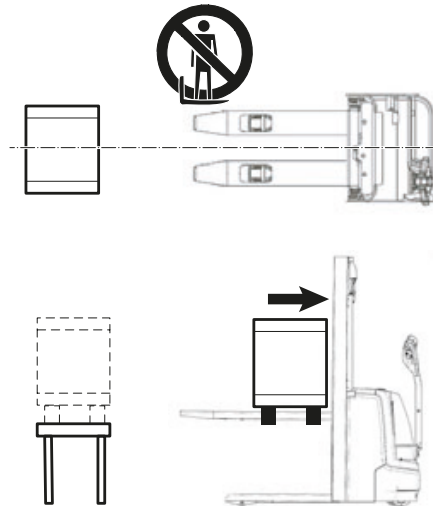

- The additional pallet stop allows double pallets to be stacked without the subsequent need to align the pallets on top of each other.

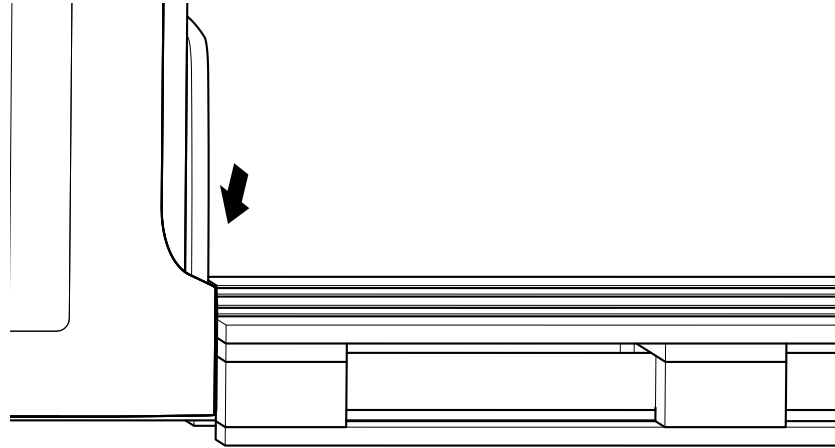

#### 4.9.5 Transporting two palletised loads above each other

##### CAUTION!

##### **Risk to operational stability**

In order not to jeopardize the operational stability, pay attention to the weight when transporting two pallets so that the truck does not tip over.

- ▶ In order not to jeopardize the operational stability, the heavier pallet should always be transported underneath.

---

##### *Requirements*

- Load raised correctly.
- Load handler lowered as far as possible but without touching the lower load.
- Good ground conditions.

##### *Procedure*

- Accelerate and decelerate with care.
- Adapt your travel speed to the conditions of the route and the load you are transporting.
- Travel at a constant speed.
- Watch out for other traffic at crossings and passageways.
- Always travel with a lookout at blind spots.
- On slopes and inclines always carry the load facing uphill, never approach at an angle or turn.

#### 4.9.6 Lowering two palletised loads in turn

##### CAUTION!

Loads must not be deposited on travel or escape routes, in front of safety mechanisms or plant equipment that must be accessible at all times.

---

##### *Requirements*

- Storage location suitable for storing the load.

##### *Procedure*

- Drive the truck carefully up to the first storage location.
- Lower the support arms until the load is resting on the floor.
- Carefully move the support arms out of the pallet.
- Drive the truck carefully up to the second storage location.
- Lowers the load handler.
-  To avoid damaging the load and the load handler, avoid setting the load down abruptly.
- Lower the load handler so that it is clear of the load (see page 77).
- Carefully drive the load handler out from beneath the pallet.

*Both pallets are lowered.*

## 5 Troubleshooting

This chapter enables the operator to localize and rectify basic faults or the results of incorrect operation himself. When trying to locate a fault, proceed in the order shown in the remedy table.



If, after carrying out the following remedial action, the truck cannot be restored to operation or if a fault in the electronics system is displayed with a corresponding error code, contact the manufacturer's service department.

Troubleshooting must only be performed by the manufacturer's customer service department. The manufacturer has a service department specially trained for these tasks.

In order for customer services to react quickly and specifically to the fault, the following information is essential:

- Truck serial number
- Event message from the display unit (if applicable)
- Error description
- Current location of truck.

## 5.1 Truck does not start

Possible cause	Remedy
Battery connector not plugged in	Check the battery connector and insert if necessary
Emergency Disconnect pressed	Release the Emergency Disconnect switch, see page 66
Key switch set to O	Set the key switch to "I"
Battery charge too low	Check battery charge, charge the battery as required
Faulty fuse	Check the fuses, see page 143
Incorrect ISM access module (○) transponder used	Use correct transponder
Incorrect CANCode (○) PIN entered	Enter correct PIN, see page 96
"Raise load handler" / "Lower load handler" button not in home position when truck switched on (for CanDis (○) event message E-2951 appears)	Do not press button
Travel switch not in home position when truck switched on (for CanDis (○) event message E-1901 appears)	Do not apply travel switch
Collision safety switch applied when truck switched on (for CanDis (○) event message E-1914 appears)	Do not apply collision safety switch
"Slow travel" switch applied when truck switched on (for CanDis (○) event message E-1901 appears)	Do not apply switch



## 5.2 Load cannot be lifted

Possible Cause	Remedy
Truck not operational	Carry out all measures listed under "Truck does not start"
Hydraulic oil level too low	Check the hydraulic oil level, see page 140
Battery discharge monitor has switched off	Charge the battery, see page 41
Faulty fuse	Check the fuses, see page 143
Excessive load	Note maximum capacity, see data plate
"Raise load handler" / "Lower load handler" button not in home position when truck switched on (for CanDis (○) event message E-2951 appears)	Do not press button
Travel switch not in home position when truck switched on (for CanDis (○) event message E-1901 appears)	Do not apply travel switch
Collision safety switch applied when truck switched on (for CanDis (○) event message E-1914 appears)	Do not apply collision safety switch
"Slow travel" switch applied when truck switched on (for CanDis (○) event message E-1901 appears)	Do not apply switch

## 6 Operating the truck without its own drive system

- With the right optional equipment (○) it is possible to switch the truck to emergency operation via the GF60 service key: The brakes are released electrically and the truck can move without its own drive system, see "Emergency operation with service key GF60" on page 92.

### 6.1 Release and activate the drive wheel brake

#### **WARNING!**

##### **Accidental truck movement**

When the brakes are de-activated the truck must be parked on a level surface, since the brakes are no longer effective.

- ▶ Do not release the brake on slopes or inclines.
- ▶ Do not park the truck with the brake released.
- ▶ Apply the brake again when you reach your destination.

---

##### ***Release the brake***

###### *Tools and Material Required*

- Two M5x16 screws
- Spanner wrench

###### *Procedure*

- Switch off the truck, to do this:
  - Turn the key in the key switch (2) anti-clockwise as far as it will go. Remove the key from the key switch (2).
  - For CanCode (○) press the O key.
  - Press the red button on the ISM access module(○).
- Press the Emergency Disconnect switch (19).
- Open the battery cover, see "Exposing the battery" on page 40.
- Disconnect the battery.
- Take off of the front panel (67) and right-hand drive panel (68), see page 139.
- Use wedges to prevent the truck from moving.
- Insert two M5x16 screws (69) as far as they will go in the brake (70) and lift up the anchor plate.

- The two M5x16 screws (69) are used to tension (unlock) the compression springs which activate the parking brake, so that the truck does not brake when de-energised.

- Remove the wedges.

*The brake is now released. The truck can be moved.*

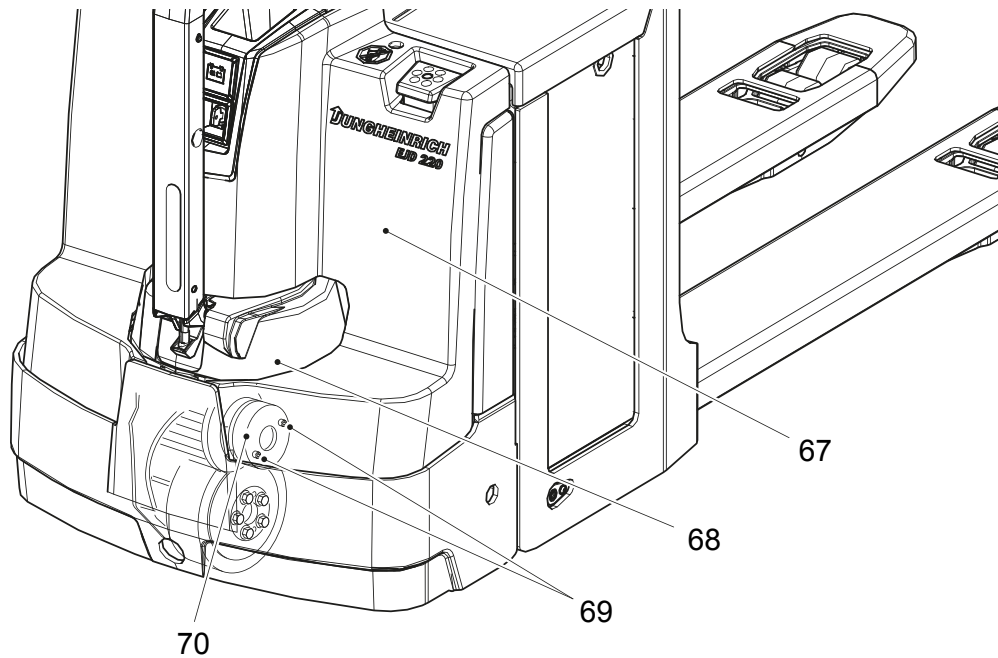

### **Activating the brake**

#### *Procedure*

- Use wedges to prevent the truck from moving.
- Remove the two M5x16 screws (69) from the brake (70).

#### **⚠ CAUTION!**

#### **Open covers can cause injury and accidents**

► The covers (battery cover, side panels, drive compartment cover etc.) must be closed during operation.

- 
- Fit the right-hand drive panel (68).
  - Fit the front panel (67).

*The brake has been reactivated. The brake is now be applied without current.*

#### **⚠ WARNING!**

Only return the truck to service when you have identified and rectified the fault.

---

## 7 Load handler emergency lowering

### **WARNING!**

#### **Lowering the mast can result in injuries**

- ▶ Instruct other people to move out of the hazardous area of the truck during emergency lowering.
- ▶ Never stand underneath a raised load handler.
- ▶ If a second person is used to lower the load handler via the emergency lowering device, this person must consult with the operator. Both people must be in a safe area to avoid danger.
- ▶ Emergency lowering is prohibited when the load handler is in the rack.
- ▶ Report any defects immediately to your supervisor.
- ▶ Mark defective truck and take out of service.
- ▶ Do not return the industrial truck to service until you have identified and rectified the fault.

#### ***Load handler emergency lowering***

##### *Requirements*

- Load handler is not in the rack.

##### *Tools and Material Required*

- 3 mm diameter pin, tool etc.
- Allen key 5 mm

##### *Procedure*

- Park the truck securely, see "Parking the truck securely" on page 63.
- Open the front panel, see "Front cover disassembly" on page 139.
- Unscrew the valve screw 2 turns (72) as far as the stop.
- Push the valve screw (71) in gradually and keep it pressed down.

*The load handler is lowered.*

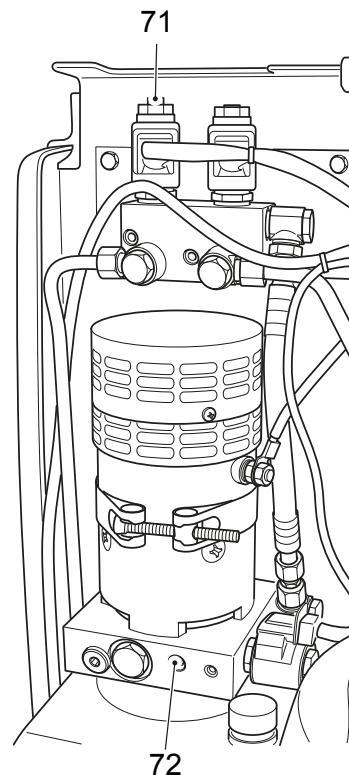

-  After lowering the load handler, tighten the screw (72) again.

## 8 Optional equipment

### 8.1 Emergency operation with service key GF60

#### **WARNING!**

##### **Accidental truck movement**

When the brakes are de-activated the truck must be parked on a level surface, since the brakes are no longer effective.

- ▶ Do not release the brake on slopes or inclines.
- ▶ Do not park the truck with the brake released.
- ▶ Apply the brake again when you reach your destination.

-  The service key GF60 must not remain on the truck during normal operation. The service key should only be used by an authorised person (e.g. warehouse manager).

##### ***Operating the truck without its own drive system.***

###### *Requirements*

- Truck prevented from rolling away.
- Charged battery in truck.

###### *Tools and Material Required*

- Service key GF60 with lock bar

###### *Procedure*

- Insert the service key GF60 in the key switch.
-  The service key GF60 with lock bar can only be inserted and turned on one side. If inserted in the wrong direction the key will not turn.
- Turn service key to position 1.
  - Move the lock bar on the head of the key.
  - Turn service key to position 2.

*The truck can be moved without its own drive system.*

GF 60

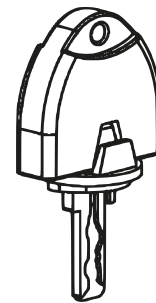

#### **CAUTION!**

##### **Risk of accident when the brake is released**

The operator must pay special care and attention when moving the truck with the brake released. The truck can be braked by the following measures:

- ▶ Turning the service key to position 1.
- ▶ Pressing the emergency disconnect switch.

## ***Parking the truck***

### *Procedure*

- Turn the service key to the 0 position and remove the key.
- After switching back from level 2 to level 1, the lock bar returns to its original position.

*The brake is now activated again.*

### **⚠ WARNING!**

Only return the truck to service when you have identified and rectified the fault.

---

- The GF30 key (without lock bar) is for normal operation.  
The key can be inserted in both directions and can only be turned to position 1 in the key switch.

GF 30



## 8.2 CanCode Keypad (○)

### 8.2.1 Code lock

The code lock allows a user or group of users to assign an individual user code. Travel programs can also be assigned to the individual user codes. The user code is configured with a master code and is described in the following sections in this chapter.

When you have entered the valid user code the truck will be operational. The truck will be able to perform travel, steering and hydraulic operations.

When you have entered the valid master code, the truck will be switched on. Travel operations are, however, inhibited. The truck will be able to perform hydraulic operations. The code lock is in programming mode. When you enter one of the following parameters, the settings in the code lock can be changed.

Parameter	Description
0-0-0	– Change master code (see "Changing the master code" on page 97)
0-0-1	– Add user codes (see "Add operator code" on page 99)
0-0-2	– Change a user code (see "Change operator code" on page 101)
0-0-3	– Delete a user code (see "Delete individual user codes" on page 103)
0-0-4	– Delete all user codes (see "Delete all user codes," on page 105)
0-1-0	– Switch on the truck automatically (see "Setting the automatic truck cutout (timeframe)" on page 107)
0-2-4	– Assign travel programs to the user codes (see "Assigning the travel program" on page 109)

Newly supplied trucks have the code indicated on a sticker. When using the truck for the first time change the master and user codes and remove the sticker.

- User code factory setting: 2-5-8-0
- Master code factory setting: 7-2-9-5



#### **WARNING!**

#### **Lack of usage restrictions can result in accidents**

If the same codes are used to operate different trucks, there is no restriction of usage for the operators or operator groups.

- ▶ When allocating the codes, ensure rider trucks are given a different code from pedestrian trucks.

The keypad consists of 10 digit keys, a Set key (76) and a  $\odot$  key (78).

### Digit keys

The digit keys are used to enter the user or master code and select the travel program.

The green LEDs of the digit keys 1, 2 and 3 (73, 74, 75) show the travel program setting.

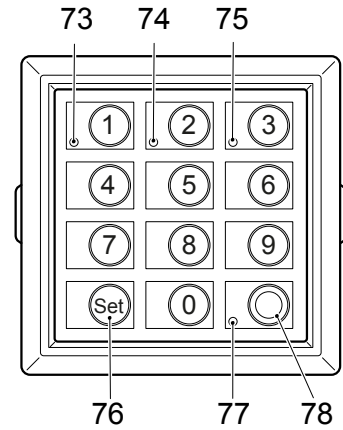

### $\odot$ key

Pressing the  $\odot$  key switches the truck off and sets it to "non operational" status.

The  $\odot$  key indicates the follow operating conditions via a red / green LED (77):

- Code lock function (commissioning the truck).
- Error display configuring the user code.
- Adjusting the travel program depending on the setting and truck.
- Setting and changing parameters.

### SET key

When you change the parameters the SET key (76) acts as a confirmation key.



## 8.2.2 Preparing the truck for operation with the keypad (CanCode)

### ***Preparing the truck for operation by entering a valid operator code***

#### *Procedure*

- Pull the Emergency Disconnect to unlock it, see "Emergency Disconnect" on page 66.

*The LED (77) lights up red.*

- Enter the operator code with the digit keys.

*When you have entered a valid operator code the LED (77) lights up green, the travel program selected is indicated by the corresponding LEDs (73,74,75) and the truck is switched on.*



If the LED (77) flashes red this means the wrong code has been entered. Enter the code again.

The Set key (76) has no function in operating mode.

## 8.2.3 Switching off the truck with the keypad (CanCode)

### ***Switching off the truck***

#### *Procedure*

- Press the O key (78).

*The truck is switched off and the LED (77) is lit red.*



The truck can cut out automatically after a specified time. If no travel, steering or hydraulic operations are performed within a set time, the truck switches off automatically. When you enter a valid code again the truck will be operational. The code lock parameter responsible for automatic cutout must be set, see "Setting the automatic truck cutout (timeframe)" on page 107.

### **Fixed cutout time (O)**

An automatic truck cutout is factory-set. The cutout time is factory-set to 5 minutes.



This setting can be changed if required.

## 8.2.4 Changing the master code

- To change the length of the master code you must follow the procedure in "Choose length of the new master code (4-6 digit) and add user codes", see "Choose length of the new master code (4-6 digit) and add user codes" on page 106. If there are still user codes stored in the code lock, the master code to be changed must be the same length as the saved user codes.

### Requirements

- To prepare the truck for operation, see "Preparing the truck for operation with the keypad (CanCode)" on page 96.

### Procedure

- Press the O key (78).
- Enter the valid master code with the digit keys.  
*When you enter the valid master code the LED (77) flashes green.*
- Enter the parameters 0-0-0 with the digit keys.
- Confirm with the SET key (76).  
*The LEDs (73,77) flash green.*
- Enter the valid master code again with the digit keys.
- Confirm with the SET key (76).  
*The LEDs (74,77) flash green.*

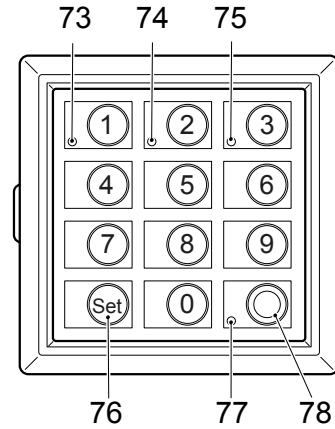

- The new master code must be different from existing user codes.
- Confirm with the SET key (76).  
*The LEDs (75,77) flash green.*
  - Enter the new master code again with the digit keys.
  - Confirm with the SET key (76).  
*Wait until the LED (77) flashes green. The setting is saved.*
  - Press the O key (78).  
*The truck is switched off and the LED (77) is lit red.*
  - Check the new master code:
    - Switch on the truck with the new master code, see "Preparing the truck for operation with the keypad (CanCode)" on page 96  
*When you enter the valid master code the LED (77) flashes green.*
    - Press the O key (78).  
*The truck is switched off and the LED (77) is lit red.*

## Error displays changing the master code

For the following events the LED (77) flashes red:

Cause	Remedy
– New master code is already occupied by a user code	– Switch off the truck, see "Switching off the truck with the keypad (CanCode)" on page 96. – Choose a different master code, see "Changing the master code" on page 97. – Change the user code so that the required master code can be used, see "Change operator code" on page 101. – Delete the user code so that the required master code can be used, see "Delete individual user codes" on page 103.
– The master codes to be changed do not match	– Switch off the truck, see "Switching off the truck with the keypad (CanCode)" on page 96. – Enter the master code again, see "Changing the master code" on page 97.
– The master code entered is not the same length as the user code	– Switch off the truck, see "Switching off the truck with the keypad (CanCode)" on page 96. – Repeat the entry, making sure that the length of the master code matches that of the user code.

## 8.2.5 Add operator code

### Requirements

- To prepare the truck for operation, see "Preparing the truck for operation with the keypad (CanCode)" on page 96.

### Procedure

- Press the O key (78).
- Enter the valid master code with the digit keys.  
*When you enter the valid master code the LED (77) flashes green.*

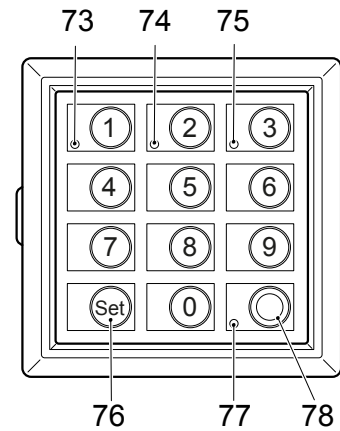

- Enter the parameters 0-0-1 with the digit keys.  
*The LEDs (74,77) flash green.*
- Confirm with the SET key (76).



- Enter the new user code with the digit keys.  
*The length (4-6 digit) of the new user code must be the same as that of the previously entered master code. The new user code must also be different from the existing master code.*
- Confirm with the SET key (76).  
*The LEDs (75,77) flash green.*
- Enter the new user code again with the digit keys.
- Confirm with the SET key (76).  
*Wait until the LED (77) flashes green. The setting is saved.*
- Press the O key (78).  
*The truck is switched off and the LED (77) is lit red.*
- Check the new user code:
  - Switch on the truck with the new user code, see "Preparing the truck for operation with the keypad (CanCode)" on page 96  
*After entering the valid user code the LED (77) lights up green, the travel program setting is shown by the illumination of the corresponding LEDs (73,74,75) and the truck is switched on.*
  - Press the O key (78).  
*The truck is switched off and the LED (77) is lit red.*

## Error displays adding a user code

For the following events the LED (77) flashes red:

<b>Cause</b>	<b>Remedy</b>
<ul style="list-style-type: none"><li>- The user code entered is not the same length as the master code</li></ul>	<ul style="list-style-type: none"><li>- Switch off the truck, see "Switching off the truck with the keypad (CanCode)" on page 96.</li><li>- Repeat the entry, making sure that the master code is the same length as the user code.</li></ul>
<ul style="list-style-type: none"><li>- New user code is already occupied by a master code</li></ul>	<ul style="list-style-type: none"><li>- Switch off the truck, see "Switching off the truck with the keypad (CanCode)" on page 96.</li><li>- Choose a different user code, see "Add operator code" on page 99.</li></ul>
<ul style="list-style-type: none"><li>- The newly entered user codes do not match</li></ul>	<ul style="list-style-type: none"><li>- Switch off the truck, see "Switching off the truck with the keypad (CanCode)" on page 96.</li><li>- Add the user code again, see "Add operator code" on page 99.</li></ul>
<ul style="list-style-type: none"><li>- Code log full.</li></ul>	<ul style="list-style-type: none"><li>- Switch off the truck, see "Switching off the truck with the keypad (CanCode)" on page 96.</li><li>- Delete individual user codes, see "Delete individual user codes" on page 103.</li><li>- Delete all user codes, see "Delete all user codes," on page 105.</li></ul>

## 8.2.6 Change operator code

### Requirements

- To prepare the truck for operation, see "Preparing the truck for operation with the keypad (CanCode)" on page 96.

### Procedure

- Press the O key (78).
- Enter the valid master code with the digit keys.  
*When you enter the valid master code the LED (77) flashes green.*

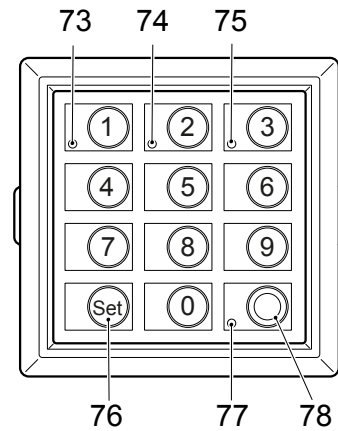

- Enter the parameters 0-0-2 with the digit keys.
- Confirm with the SET key (76).  
*The LEDs (73,77) flash green.*
- Enter the user code to be changed with the digit keys.
- Confirm with the SET key (76).  
*The LEDs (74,77) flash green.*
- Enter the new user code with the digit keys.  
→ The length (4-6 digit) of the new user code must be the same as that of the previously entered master code. The new user code must also be different from the existing master code.
- Confirm with the SET key (76).  
*The LEDs (75,77) flash green.*
- Enter the new user code again with the digit keys.
- Confirm with the SET key (76).  
*Wait until the LED (77) flashes green. The setting is saved.*
- Press the O key (78).  
*The truck is switched off and the LED (77) is lit red.*
- Check the new user code:
  - Switch on the truck with the new user code, see "Preparing the truck for operation with the keypad (CanCode)" on page 96  
*After entering the valid user code the LED (77) lights up green, the travel program setting is shown by the illumination of the corresponding LEDs (73,74,75) and the truck is switched on.*
  - Press the O key (78).  
*The truck is switched off and the LED (77) is lit red.*

## Error displays changing a user code

For the following events the LED (77) flashes red:

Cause	Remedy
<ul style="list-style-type: none"><li>- The user code entered is not the same length as the master code</li></ul>	<ul style="list-style-type: none"><li>- Switch off the truck, see "Switching off the truck with the keypad (CanCode)" on page 96.</li><li>- Repeat the entry, making sure that the master code is the same length as the user code.</li></ul>
<ul style="list-style-type: none"><li>- Operator code to be changed does not exist.</li></ul>	<ul style="list-style-type: none"><li>- Switch off the truck, see "Switching off the truck with the keypad (CanCode)" on page 96.</li><li>- Check the user code entered.</li></ul>
<ul style="list-style-type: none"><li>- The user codes to be changed do not match</li></ul>	<ul style="list-style-type: none"><li>- Switch off the truck, see "Switching off the truck with the keypad (CanCode)" on page 96.</li><li>- Change the user code again, see "Change operator code" on page 101.</li></ul>
<ul style="list-style-type: none"><li>- Tried to change the operator code to another user code that already exists.</li></ul>	<ul style="list-style-type: none"><li>- Switch off the truck, see "Switching off the truck with the keypad (CanCode)" on page 96.</li><li>- Choose a different user code, see "Change operator code" on page 101.</li></ul>

## 8.2.7 Delete individual user codes

### Requirements

- To prepare the truck for operation, see "Preparing the truck for operation with the keypad (CanCode)" on page 96.

### Procedure

- Press the O key (78).
- Enter the valid master code with the digit keys.  
*When you enter the valid master code the LED (77) flashes green.*
- Enter the parameters 0-0-3 with the digit keys.
- Confirm with the SET key (76).  
*The LEDs (74,77) flash green.*
- Enter the user code to be deleted with the digit keys.
- Confirm with the SET key (76).  
*The LEDs (75,77) flash green.*
- Enter the user code to be deleted again with the digit keys.
- Confirm with the SET key (76).  
*Wait until the LED (77) flashes green. The user code is now deleted.*
- Press the O key (78).  
*The truck is switched off and the LED (77) is lit red.*
- Check that the user code has been deleted:
  - Switch the truck on with the user code to be deleted, see "Preparing the truck for operation with the keypad (CanCode)" on page 96  
*After entering the user code the LED (77) flashes red and the truck remains switched off.*
  - Press the O key (78).  
*The truck remains switched off and the LED (77) is lit red.*

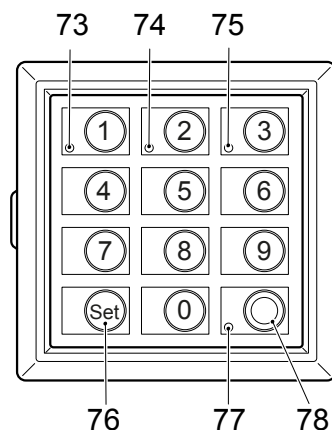



## Error displays deleting individual user codes

For the following events the LED (77) flashes red:

<b>Cause</b>	<b>Remedy</b>
– The user code entered is not the same length as the master code	– Switch off the truck, see "Switching off the truck with the keypad (CanCode)" on page 96. – Repeat the entry, making sure that the master code is the same length as the user code.
– Tried to delete an operator code that does not exist.	– Switch off the truck, see "Switching off the truck with the keypad (CanCode)" on page 96. – Check the user code entered.
– The user codes to be changed do not match	– Switch off the truck, see "Switching off the truck with the keypad (CanCode)" on page 96. – Delete the user code again, see "Delete individual user codes" on page 103.

## 8.2.8 Delete all user codes,

### Requirements

- To prepare the truck for operation, see "Preparing the truck for operation with the keypad (CanCode)" on page 96.

### Procedure

- Press the O key (78).
- Enter the valid master code with the digit keys.  
*When you enter the valid master code the LED (77) flashes green.*
- Enter the parameters 0-0-4 with the digit keys.
- Confirm with the SET key (76).  
*The LEDs (75,77) flash green.*
- Enter the code 3-2-6-5 with the digit keys.
- Confirm with the SET key (76).  
*Wait until the LED (77) flashes green. All user codes are deleted.*
- Press the O key (78).  
*The truck is switched off and the LED (77) is lit red.*
- Check that the user codes have been deleted:
  - Switch on the truck with a previous user code, see "Preparing the truck for operation with the keypad (CanCode)" on page 96.  
*After entering the user code the LED (77) flashes red and the truck remains switched off.*
  - Press the O key (78).  
*The truck remains switched off and the LED (77) is lit red.*

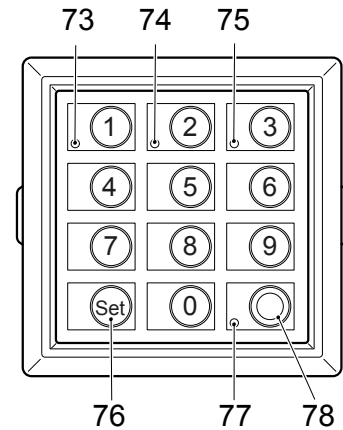

### 8.2.9 Choose length of the new master code (4-6 digit) and add user codes

- The master code is factory set to a four-digit entry: If necessary, the four-digit master code can be changed to a five or six-digit entry. Before the master code length can be changed, all user codes must be deleted. The length of the user code (4-6 digit) is always determined by the length of the master code.

#### Requirements

- To prepare the truck for operation, see "Preparing the truck for operation with the keypad (CanCode)" on page 96.

#### Procedure

- Delete all user codes, see "Delete all user codes," on page 105.
- Enter the new master code (4-6 digit), see "Changing the master code" on page 97.
- Add user codes again, see "Add operator code" on page 99.

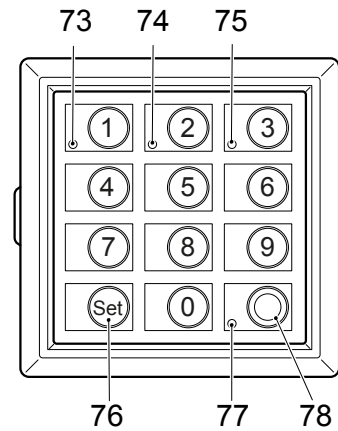

*The length of the new master code is now changed and user codes have been added.*

## 8.2.10 Setting the automatic truck cutout (timeframe)

### Requirements

- To prepare the truck for operation, see "Preparing the truck for operation with the keypad (CanCode)" on page 96.

### Procedure

- Press the O key (78).
- Enter the valid master code with the digit keys.  
*When you enter the correct master code the LED (77) flashes green.*
- Enter the 0-1-0 parameter with the digit keys.
- Confirm with the SET key (76).  
*Wait until the LED (77) flashes green.*
- Set the truck automatic cutout (time period) with the digit keys:
  - 00:  
Automatic truck cutout is deactivated.
  - 01 - 30:  
Set time period (in minutes) after which the truck automatically cuts out (minimum cutout time is 1 minute, maximum cutout time is 30 minutes).
  - 31:  
After 10 seconds the truck cuts out automatically.
- Confirm with the SET key (76).  
*Wait until the LED (77) flashes green. The setting is saved.*
- Press the O key (78).  
*The truck is switched off and the LED (77) lights up red.*
- Checking the truck's automatic cutout:
  - Switch on the truck with a valid operator code, see "Preparing the truck for operation with the keypad (CanCode)" on page 96.  
*When you have entered a valid operator code the LED (77) lights up green, the travel program selected is indicated by the corresponding LEDs (73,74,75) and the truck is switched on.*
  - Do not perform any travel, steering or hydraulic operations with the truck.
  - Wait until the truck automatically cuts out at the end of the time period.  
*The truck is switched off and the LED (77) lights up red.*

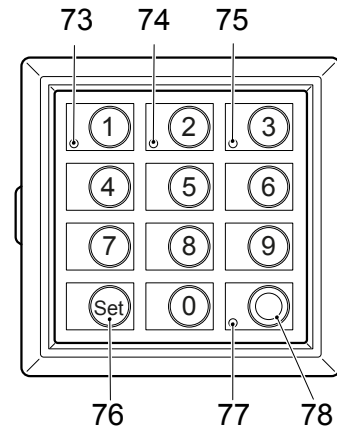

### Error displays setting the automatic cutout period of the truck

For the following events the LED (77) flashes red:

Cause	Remedy
<ul style="list-style-type: none"> <li>– Cutout time entered is out of range</li> </ul>	<ul style="list-style-type: none"> <li>– Switch off the truck, see "Switching off the truck with the keypad (CanCode)" on page 96.</li> <li>– Enter the time again while making sure it is within range.</li> </ul>

### Fixed cutout time (○)

An automatic truck cutout is factory-set. The cutout time is factory-set to 5 minutes.

 This setting can be changed if required.

### 8.2.11 Assigning the travel program

The travel programs are fixed to the user code and can be released or blocked with a configuration code. The configuration code can also be used to assign a starting travel program to each user code.

- The starting travel program is the travel program that is activated when the truck is switched on and is displayed by the (73,74,75) LEDs.
- LED (73) lit = travel program 1 activated
  - LED (74) lit = travel program 2 activated
  - LED (75) lit = travel program 3 activated

The configuration code is four-digit and is comprised as follows:

- 1st digit: Specifies the authorisation for travel program 1:
- 2nd digit: Specifies the authorisation for travel program 2:
- 3rd digit: Specifies the authorisation for travel program 3:
- 4. digit: Specifying the starting travel program

When you add or change a user code all travel programs are enabled, the starting travel program is travel program 2.

## Specifying a configuration code:

	Setting	Description
1st digit	0	– Travel program 1 is blocked for the user code selected
	1	– Travel program 1 is enabled for the user code selected
2nd digit	0	– Travel program 2 is blocked for the user code selected
	1	– Travel program 2 is enabled for the user code selected
3rd digit	0	– Travel program 3 is blocked for the user code selected
	1	– Travel program 3 is enabled for the user code selected
4th digit	0	– When the truck has been switched on with the selected user code, no travel program is activated
	1	– When the truck has been switched on with the selected user code, travel program 1 is activated
	2	– When the truck has been switched on with the selected user code, travel program 2 is activated
	3	– When the truck has been switched on with the selected user code, travel program 3 is activated



The default setting for the travel program configuration code is:  
1-1-1-2.

**Meaning:**

Travel programs 1, 2 and 3 are enabled.

When the truck has been switched on with the selected user code, travel program 2 is activated

## Adapting the travel program configuration to the user code

### Procedure

- Press the O key (78).
- Enter the valid master code with the digit keys.  
*When you enter the valid master code the green LED (77) flashes green.*
- Enter the parameters 0-2-4 with the digit keys.
- Confirm with the SET key (76).  
*The LEDs (73,77) flash green.*
- Enter the valid user code with the digit keys.
- Confirm with the SET key (76).  
*The LEDs (74,77) flash green.*
- Enter the configuration code (4 digit) for the travel programs.
- Confirm with the SET key (76).  
*The LEDs (75,77) flash green.*
- Enter the configuration code (4 digit) for the travel programs again using the digit keys.
- Confirm with the SET key (76).  
*Wait until the LED (77) flashes green. The travel programs are now assigned to the user code.*
- Press the O key (78).  
*The truck is switched off and the LED (77) is lit red.*
- Checking the travel program configuration to the user code:
  - Switch on the truck with the configured user code, see "Preparing the truck for operation with the keypad (CanCode)" on page 96  
*After entering the valid user code the LED (77) lights up green, the travel program setting is shown by the illumination of the corresponding LEDs (73,74,75) and the truck is switched on.*
  - Press the O key (78).  
*The truck is switched off and the LED (77) is lit red.*
- If necessary, repeat the procedure for other user codes.

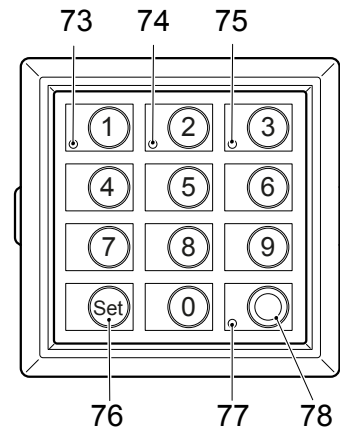



## Error displays configuring the travel programs

For the following events the LED (77) flashes red:

<b>Cause</b>	<b>Remedy</b>
– Blocked travel program defined as start travel program	– Switch off the truck, see "Switching off the truck with the keypad (CanCode)" on page 96. – Try again, making sure the configuration code is entered correctly.

## 8.3 Setting the truck parameters with CanCode

### CAUTION!

#### Faulty entry

Without CanDis only CanCode internal parameters can be changed. Traction controller parameters can only be changed with CanDis, without CanDis the settings must be performed by the manufacturer's service department.

---

### CAUTION!

#### **Altering settings for the travel, steering and hydraulic functions can result in accidents**

Increasing or decreasing the settings for travel, steering and hydraulic functions can result in accidents.

- ▶ Carry out a test run in a secure environment.
  - ▶ This requires greater attention on the part of the operator.
- 

#### **Parameter setting example**

The following example shows the parameter setting for the acceleration of travel program 1 (parameter 0256).

#### **Acceleration example**

##### *Procedure*

- Enter four-digit parameter number "0256" and confirm with the SET key (76).
- Enter sub-index (enter "2") and confirm with the SET key (76).
- The parameter and sub index are displayed alternately with the current reading (0256-2<->0000-3).
- Enter the parameter according to the parameter list and confirm with the Set key (76).
- The LED (77) of the O key (78) switches briefly to steady light and start flashing again after approx. 2 seconds.
- If the entry is incorrect, the LED (77) of the O key (78) turns red. Enter the parameter number again to repeat the setting.
- The parameter and sub index are displayed alternately with the entry (0256-2<->0000-5).

*The travel parameter is now set.*

Repeat the procedure to enter further parameters as soon as the LED (77) of the O key (78) flashes.

- Travel is disabled while the parameters are being entered.

#### **Checking the settings in programming mode**

##### *Procedure*

- Select the travel program to be worked on after changing the parameter value, and confirm with the Set key (76).

*The truck is now in travel mode and can be checked.*

➔ To continue setting, confirm with the Set key (76) again.

### ***Saving travel parameters***

#### *Requirements*

– Enter all parameters.

#### *Procedure*

- Run "SaveParameters" by pressing 1-2-3-Set.
- Confirm with the O key (78).

## 8.4 Parameters

### Travel program 1

No.	Function	Setting Setting	Standard Setting	Comments
0256	Acceleration	0 - 9 (0.2 – 2.0 m/s <sup>2</sup> )	1 (0,4 m/s <sup>2</sup> )	
0260	Coasting brake	0 - 19 (0.2 – 3,3 m/s <sup>2</sup> )	3 (0,5 m/s <sup>2</sup> )	
0262	Reversing brake	0 - 9 (0.19-1.54 m/s <sup>2</sup> )	6 (0,75 m/s <sup>2</sup> )	
0264	Maximum speed in drive direction via controller	24 - 60 (2,4 - 6,0 km/h)	40 (4,0 km/h)	depending on travel switch
0268	Maximum speed in fork direction via controller	24 - 60 (2,4 - 6,0 km/h)	40 (4,0 km/h)	depending on travel switch

### Travel program 2

No.	Function	Setting Setting	Standard Setting	Comments
0272	Acceleration	0 - 9 (0.2 – 2.0 m/s <sup>2</sup> )	2 (0,6 m/s <sup>2</sup> )	
0276	Coasting brake	0 - 19 (0.2 – 3,3 m/s <sup>2</sup> )	4 (0,6 m/s <sup>2</sup> )	
0280	Maximum speed in tiller direction via controller	24 - 60 (2,4 - 6,0 km/h)	52 (5,2 km/h)	depending on travel switch
0284	Maximum speed in fork direction via controller	24 - 60 (2,4 - 6,0 km/h)	52 (5,2 km/h)	depending on travel switch

### Travel program 3

No.	Function	Setting Setting	Standard Setting	Comments
0288	Acceleration	0 - 9 (0.2 – 2.0 m/s <sup>2</sup> )	5 (1,2 m/s <sup>2</sup> )	
0292	Coasting brake	0 - 19 (0.2 – 3,3 m/s <sup>2</sup> )	6 (0,8 m/s <sup>2</sup> )	
0296	Maximum speed in tiller direction via controller	24 - 60 (2,4 - 6,0 km/h)	60 (6,0 km/h)	depending on travel switch
0300	Maximum speed in fork direction via controller	24 - 60 (2,4 - 6,0 km/h)	60 (6,0 km/h)	depending on travel switch

## Common parameters

No.	Function	Setting Setting	Standard Setting	Comments
0267	Slow travel speed in drive direction	16 - 34 (1,6 - 3,4 km/h)	20 (2,0 km/h)	depending on travel switch
0267	Slow travel speed in fork direction	16 - 34 (1,6 - 3,4 km/h)	20 (2,0 km/h)	depending on travel switch
0384	Reduction brake	0 - 9 (0.2 – 1,14 m/s <sup>2</sup> )	2 (0,42 m/s <sup>2</sup> )	Deceleration for travel switch setting reduction
0385	Service brake	0 - 9 (0,5 – 3,3 m/s <sup>2</sup> )	2 (0,9 m/s <sup>2</sup> )	Deceleration for tiller in brake position
0386	Body protection brake	0 - 9 (2.03-6.54 m/s <sup>2</sup> )	4 (3,54 m/s <sup>2</sup> )	Speed reduction when body protection switch applied

## Battery parameter

No.	Function	Range	Standard setting	Comments
1377	Battery type (normal / high performance / dry)	0 - 5 7 9	1	0 = Normal (wet) 1 = High performance (wet) 2 = Dry (maintenance-free) 3 = US "Flat Plate" type 4 = US "Pallet Pro" type 5 = US "Tubular Plate" type 7 = Exide GF12063Y (Dry battery) 9 = XFC (Special battery)
1389	Discharge monitor function	0 / 1	1	0 = Not active 1 = Active

## Hydraulic function lock settings

No.	Function	Range	Standard setting	Comments <sup>1,2</sup>
2338	Lift Lower	0 - 15	1	<p>0 = Lifting and lowering always released</p> <p>1 = Lifting only with authorisation</p> <p>2 = Lifting only when stationary</p> <p>3 = Lifting only with authorisation and only when stationary</p> <p>4 = Lowering only when stationary</p> <p>5 = Lifting and lowering only with authorisation</p> <p>6 = Lifting only when stationary, lowering only with authorisation</p> <p>7 = Lowering only with authorisation, lowering only with authorisation</p> <p>8 = Lowering only when stationary</p> <p>9 = Lifting only with authorisation, lowering only when stationary</p> <p>10 = Lifting and lowering when stationary</p> <p>11 = Lifting only with authorisation and only when stationary, lowering only when stationary</p> <p>12 = Lowering only with authorisation and only when stationary</p>

1. With authorisation = with tiller in travel range (F) or with "slow travel" switch applied
2. Stationary = No travel operations performed

No.	Function	Range	Standard setting	Comments <sup>1,2</sup>
2338	Lift Lower	0 - 15	1	<p>13 = Lifting and lowering only with authorisation, lowering only when stationary</p> <p>14 = Lifting and lowering only when stationary, lowering only with authorisation</p> <p>15 = Lifting and lowering only with authorisation and only when stationary</p>

1. With authorisation = with tiller in travel range (F) or with "slow travel" switch applied
2. Stationary = No travel operations performed



## 8.5 Setting the Battery Parameters with CanCode

### **WARNING!**

#### **Altering parameters can cause accidents**

- ▶ Altering the settings can cause accidents.
- ▶ This requires greater attention on the part of the operator

The following example shows the parameter setting for the battery type (parameter 1377) to "dry - maintenance-free".

#### *Requirements*

- CanCode and CanDis are available.

#### *Procedure*

- Press the O key (78).
- Enter the master code.
- Enter the four-digit parameter number "1377" and confirm with the Set key.
- Enter sub index "2" and confirm with the Set key.

The parameter with subindex are displayed alternately with the current reading. E.g. (1377-2<->0000-1--corresponds to battery type „high-performance (wet)“.

- Enter parameter "2" according to the parameter list and confirm with the Set key. The LED of the O key switches briefly to continuous light and starts flashing again after approx. 2 seconds.

If the entry is incorrect, the LED of the O key turns red. Enter the parameter number again to repeat the setting.

The parameter and subindex are displayed alternately with the current reading (1377-2<->0000-2).

*The "dry maintenance-free" battery type is set.*

 *Travel is disabled while the parameters are being entered.*

#### **Storing the parameter**

#### *Requirements*

- The parameter is now entered.

#### *Procedure*

- Run "SaveParameters" by pressing 1-2-3-Set.
- Press the O key.

*The parameter is now saved.*

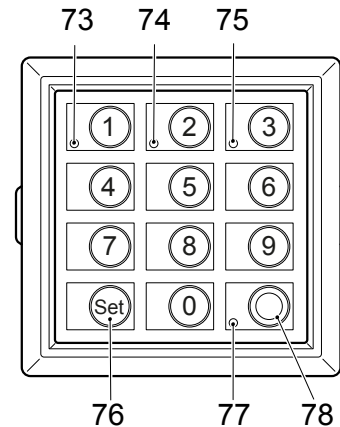

### ***Testing an altered parameter***

#### *Requirements*

- The parameter is now saved.

#### *Procedure*

- Press the O key (78).
- Enter the master code.
- Enter the four-digit parameter number "1377" and confirm with the Set key.
- Enter sub index "2" and confirm with the Set key.

The parameter with subindex are displayed alternately with the current reading.

E.g. (1377-2<->0000-2--corresponds to the "dry - maintenance-free" battery type.

- Press the O key.

*The parameter has now been checked.*

## 8.6 CanDis Display Instrument (○)

The instrument indicates:

79	Battery charge display (on board charger only)
80	LED bars for battery charge status
81	"Warning" symbol (yellow), Battery charge recommended
82	"Stop" symbol (red); lift cutout, Battery charge essential
83	No symbol when battery type set to normal or enhanced performance wet cell battery  "T" symbol appears steadily during operation when battery type set to maintenance-free  "T" symbol appears flashing during operation when battery type set to special, such as XFC
84	6 digit LCD display: – Service hours – Settings entry and changes – Event messages

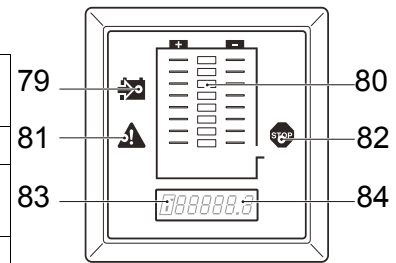

### Charge status display

The charge status is shown through eight LED bars.

Eight lit LED bars correspond to a fully charged battery. One lit LED bar corresponds to an almost discharged battery.

When the "Attention" symbol (81) starts to flash, it is advisable to charge the battery.

If the "Attention" symbol (81) is lit steadily, the battery must be charged.

If the "Stop" symbol (82) is lit steadily, the battery must be **charged** immediately. If activated, the discharge monitor function is applied in this case, see "Discharge monitor function" on page 123.

- The point at which the "Attention" (81) and "Stop" (82) symbols start to light up differs depending on the battery type.

### 8.6.1 Discharge monitor function

The discharge limit has been reached when the "Stop" symbol (82) lights up. When the discharge monitor function is activated lifting operations are disabled. Travel and lowering are still possible.

Lifting is only enabled again when the battery is 70% charged.

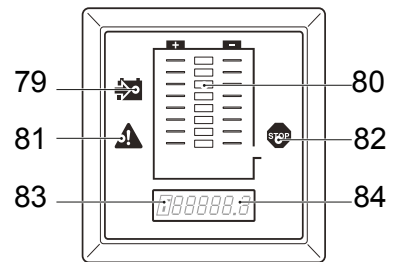

### 8.6.2 Service hour display

The service hour display range is between 0.0 and 99,999.0 hours. The display (84) has background lighting.

- For maintenance-free batteries a "T" (83) symbol is shown in the display.
- For special batteries the "T" (83) symbol flashes in the service hour display.

### 8.6.3 Event Messages

The service hours display is also used to display event messages. The event messages overwrite the service hour display. Event message start with an "E" for Event and a four-digit error number.

The event message is displayed as long as the fault persists. If there are several event messages they are displayed consecutively. Most event messages result in the Emergency Stop being activated.

- Remedies, see "Troubleshooting" on page 86.

### 8.6.4 Power up test

Once the truck has become operational the following displays appear:

- Display unit software version is flashed briefly
- Service hours
- Battery charge status

## 8.7 ISM access module (○)

- If the truck is equipped with an ISM access module refer to the "ISM Access Module" operator manual.



# F Industrial Truck Maintenance

## 1 Operational Safety and Environmental Protection

The checks and servicing operations contained in this chapter must be performed in accordance with the maintenance checklist service intervals.

### **WARNING!**

#### **Risk of accidents and component damage**

Any modification to the truck, in particular the safety mechanisms, is prohibited.

---

**Exception:** Operating companies should only make changes or have changes made to powered industrial trucks if the truck manufacturer is no longer operating in the field and there is no successor to the business; operating companies must however:

- Ensure that the changes to be made are planned, tested and performed by a specialist engineer in industrial trucks taking safety into account.
- Keep permanent records of plans, tests and completion of changes.
- Carry out and have authorised the respective changes to the capacity data plates, decals and stickers as well as the operator and service manuals.
- Attach permanent and clearly visible marking to the truck indicating the types of changes made, the date of the changes and the name and address of the organisation responsible for the work.

### **NOTE**

Only original spare parts are subject to the manufacturer's quality control. To ensure safe and reliable operation, use only the manufacturer's spare parts.

---



On completion of inspection and service work, carry out the operations listed in the "Recommissioning the truck after cleaning or maintenance work" section (see "Restoring the truck to service after maintenance and repairs" on page 144).

## 2 Maintenance Safety Regulations

### Maintenance and repair personnel

- The manufacturer has a service department specially trained for these tasks. A maintenance contract with the manufacturer will ensure trouble-free operation.

Truck maintenance and repair work must only be carried out by specially trained personnel. The following operations are assigned to the following target groups.

#### Customer Services

Customer Services are specially trained in the use of the truck and are able to carry out maintenance and repairs independently. Customer Services are aware of the relevant standards, guidelines and safety regulations as well as potential risks.

#### Operating company

The maintenance personal of the operating company has the technical expertise and experience to perform the activities in the maintenance check list for the operating company. The maintenance and repair work to be performed by the operating company are also written down, see "Maintenance and repairs" on page 134.

## 2.1 Working on the electrical system

### **WARNING!**

#### **Electrical current can cause accidents**

Make sure the electrical system is voltage-free before starting work on it. The capacitors in the controller must be completely discharged. The capacitors are completely discharged after approximately 10 minutes. Before starting maintenance on the electrical system:

- ▶ Only suitably trained electricians may operate on the truck's electrical system.
  - ▶ Before working on the electrical system, take all precautionary measures to avoid electric shocks.
  - ▶ Park the truck securely (see "Parking the truck securely" on page 63).
  - ▶ Disconnect the battery.
  - ▶ Remove any rings, metal wrist bands etc.
- 

## 2.2 Consumables and used parts

### **CAUTION!**

#### **Consumables and used parts are an environmental hazard**

Used parts and consumables must be disposed of in accordance with the applicable environmental-protection regulations. Oil changes should be carried out by the manufacturer's customer service department, whose staff are specially trained for this task.

- ▶ Note the safety regulations when handling these materials.
- 

## 2.3 Wheels

### **WARNING!**

#### **The use of wheels that do not comply with the manufacturer's specifications can result in accidents**

The quality of wheels affects the stability and driving characteristics of the truck. Uneven wear affects the truck's stability and increases the stopping distance.

- ▶ After replacing wheels, make sure the truck is not skewed.
  - ▶ Always replace wheels in pairs, i.e. the left- and right-hand wheels at the same time.
- 



When replacing wheels fitted at the factory, only use the manufacturer's original spare parts. Otherwise the manufacturer's specification will not be adhered to.



## 2.4 Hydraulic system

### **WARNING!**

#### **Leaky hydraulic systems can result in accidents**

Hydraulic oil can escape from leaky and faulty hydraulic systems.

- ▶ Report any defects immediately to your supervisor.
  - ▶ Mark defective truck and take out of service.
  - ▶ Do not return the industrial truck to service until you have identified and rectified the fault.
  - ▶ Remove any spilled hydraulic immediately with an appropriate bonding agent.
  - ▶ The bonding agent / consumable mixture must be disposed of in accordance with regulations.
- 

### **WARNING!**

#### **Faulty hydraulic hoses can result in injury and infection**

Pressurised hydraulic oil can escape from fine holes or hairline cracks in the hydraulic hoses. Brittle hydraulic hoses can burst during operation. People standing near the truck can be injured by the hydraulic oil.

- ▶ Call for a doctor immediately in the event of an injury.
  - ▶ Do not touch pressurised hydraulic hoses.
  - ▶ Report any defects immediately to your supervisor.
  - ▶ Mark defective truck and take it out of service.
  - ▶ Do not return the industrial truck to service until you have identified and rectified the fault.
- 

### **NOTE**

#### **Testing and replacing hydraulic hoses**

Hydraulic hoses can become brittle through age and must be checked at regular intervals. The application conditions of the industrial truck have a considerable impact on the ageing of the hydraulic hoses.

- ▶ Check the hydraulic hoses at least annually and replace if necessary.
  - ▶ If the operating conditions become more arduous the inspection intervals must be reduced accordingly.
  - ▶ In normal operating conditions a precautionary replacement of the hydraulic hoses is recommended after 6. The owner must carry out a risk assessment to ensure safe, prolonged use. The resulting protection measures must be observed and the inspection interval reduced accordingly.
-

## 2.5 Lift Chains

### **WARNING!**

#### **Non-lubricated and incorrectly cleaned lift chains can cause accidents**

Lift chains are safety-critical parts. They must not contain any serious contamination. Lift chains and pivot pins must always be clean and well lubricated.

- ▶ Lift chains should only be cleaned with paraffin derivatives e.g. petroleum or diesel fuels.
  - ▶ Do not clean lift chains with high pressure jets or chemical cleaning agents.
  - ▶ Immediately after cleaning, dry the lift chain with compressed air and apply a chain spray.
  - ▶ Always lubricate a chain when it is discharged.
  - ▶ Lubricate a lift chain with particular care around the pulleys.
-

## 3 Lubricants and Lubrication Schedule

### 3.1 Handling consumables safely

#### Handling consumables

Consumables must always be handled correctly. Follow the manufacturer's instructions.

#### **WARNING!**

##### **Improper handling is hazardous to health, life and the environment**

Consumables can be flammable.

- ▶ Keep consumables away from hot components and naked flames.
  - ▶ Always keep consumables in prescribed containers.
  - ▶ Always fill consumables in clean containers.
  - ▶ Do not mix up different grades of consumable. The only exception to this is when mixing is expressly stipulated in the operating instructions.
- 

#### **CAUTION!**

##### **Spilled consumables can cause slipping and endanger the environment**

Risk of slipping from spilled consumables. The risk is greater when combined with water.

- ▶ Do not spill consumables.
  - ▶ Spilled consumables must be removed immediately with an appropriate bonding agent.
  - ▶ The bonding agent / consumable mixture must be disposed of in accordance with regulations.
-



## WARNING!

### **Improper handling of oils can be hazardous**

Oils (chain spray / hydraulic oil) are flammable and poisonous.

- ▶ Dispose of used oils in accordance with regulations. Store used oil safely until it can be disposed of in accordance with regulations.
  - ▶ Do not spill oil.
  - ▶ Spilled oils must be removed immediately with an appropriate bonding agent.
  - ▶ The mixture consisting of the bonding agent and oil must be disposed of in accordance with regulations.
  - ▶ Observe national regulations when handling oils.
  - ▶ Wear safety gloves when handling oils.
  - ▶ Prevent oil from coming into contact with hot motor parts.
  - ▶ Do not smoke when handling oil.
  - ▶ Avoid contact and digestion. If you swallow oil do not induce vomiting but seek medical assistance immediately.
  - ▶ Seek fresh air after breathing in oil fumes or vapours.
  - ▶ If oil has come into contact with your skin, rinse your skin with water.
  - ▶ If oil has come into contact with your eyes, rinse them with water and seek medical assistance immediately.
  - ▶ Replace oil-soaked clothing and shoes immediately.
- 



## CAUTION!

### **Consumables and used parts are an environmental hazard**

Used parts and consumables must be disposed of in accordance with the applicable environmental-protection regulations. Oil changes should be carried out by the manufacturer's customer service department, whose staff are specially trained for this task.

- ▶ Note the safety regulations when handling these materials.
-

### 3.2 Lubrication Schedule

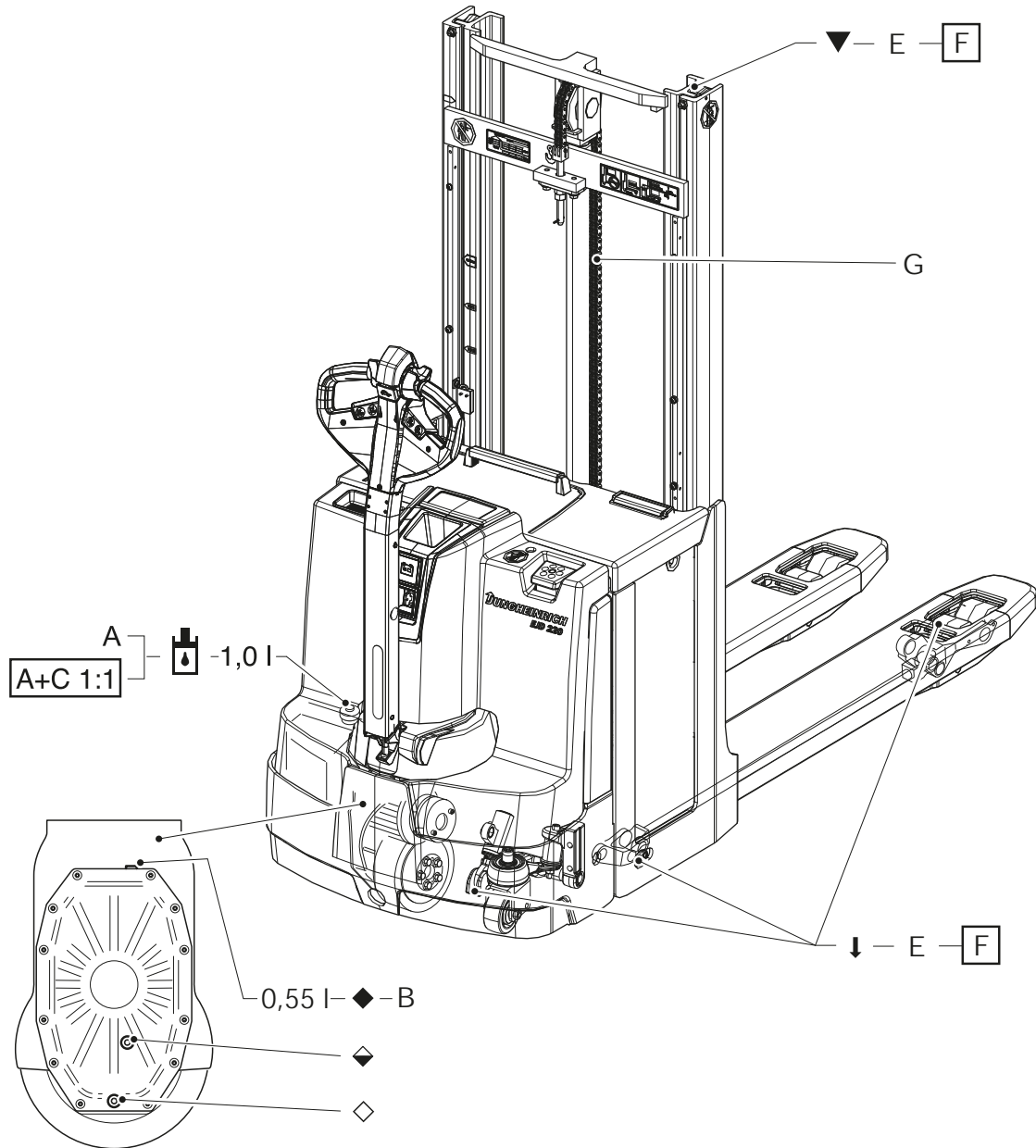

▼	Contact surfaces	*	Cold Store Application
↓	Grease nipple	◇	Transmission oil drain plug
☆	Hydraulic oil drain plug	⊕	Hydraulic oil filler neck
◆	Transmission oil filler neck	◇	Transmission oil overflow and dipstick

1 Compound ratio for cold store usage 1:1

### 3.3 Consumables

Code	Order no.	Package quantity	Component	Used for
A	51132827 *	5.0 L	Jungheinrich Hydraulic oil	Hydraulic System
	51132826 *	1.0 L		
	29200670	5.0 L	H-LP 46, DIN 51524	
B	50380904	5.0 L	Titan Gear HSY 75W-90	Transmission
C	51081875 *	5.0 L	H-LP 10, DIN 51524 Cold store hydraulic oil	Hydraulic System Additive for cold store operation
E	29202050	1.0 kg	Polylube GA 352P	Lubrication
G	29201280	0.51 L	Chain spray	Chains

#### Grease guidelines

Code	Saponification -	Dew point °C	Worked-penetration at 25 °C	NLG1 class	Application-temperature °C
E	Lithium	>220	280 - 310	2	-35/+120

\*The trucks are factory-equipped with a special hydraulic oil (the Jungheinrich hydraulic oil with a blue colouration) and the cold store hydraulic oil (red colouration). The Jungheinrich hydraulic oil can only be obtained from the Jungheinrich service department. The use of named alternative hydraulic oils is not prohibited but may lead to a decline in functionality. The Jungheinrich hydraulic oil may be mixed with one of the named alternative hydraulic oils.



For cold store operations the Jungheinrich hydraulic oil and the cold store hydraulic oil must be mixed in a 1:1 ratio.

## 4 Maintenance and repairs

### 4.1 Preparing the truck for maintenance and repairs

All necessary safety measures must be taken to avoid accidents when carrying out maintenance and repairs. The following preparations must be made:

*Procedure*

- Park the truck securely, see "Parking the truck securely" on page 63.
- Disconnect the battery to prevent the truck from being switched on accidentally.



#### **WARNING!**

#### **Risk of accidents when working under the load handler and lift truck**

- ▶ When working under a raised load handler or a raised truck, secure them to prevent the truck from lowering, tipping or sliding away.
  - ▶ When raising the truck, follow the instructions, see "Transport and Commissioning" on page 33. When working on the parking brake, prevent the truck from accidentally rolling away (e.g. with wedges).
-

## 4.2 Lifting and jacking up the truck safely



### WARNING!

#### Lifting and jacking up the truck safely

In order to raise the truck, the lifting gear must only be secured to the points specially provided for this purpose.

You may only work under a raised load handler if it has been secured with a sufficiently strong chain or the fastening bolt.

In order to raise and jack up the truck safely, proceed as follows:

- ▶ Jack up the truck only on a level surface and prevent it from moving accidentally.
  - ▶ Always use a jack with sufficient capacity. When jacking up the truck, take appropriate measures to prevent it from slipping or tipping over (e.g. wedges, wooden blocks).
  - ▶ In order to raise the truck, the lifting gear must only be secured to the points specially provided for this purpose, see "Transport and Commissioning" on page 33.
  - ▶ When jacking up the truck, take appropriate measures to prevent it from slipping or tipping over (e.g. wedges, wooden blocks).
-



## 4.3 Cleaning

### 4.3.1 Cleaning the truck

#### CAUTION!

##### **Fire hazard**

Do not use flammable liquids to clean the industrial truck.

- ▶ Disconnect the battery before starting cleaning work.
  - ▶ Carry out all necessary safety measures to prevent sparking before cleaning (e.g. by short-circuiting).
- 

#### CAUTION!

##### **Risk of component damage when cleaning the truck**

Cleaning with a pressure washer can result in malfunctions due to humidity.

- ▶ Cover all electronic system assemblies (controllers, sensors, motors etc.) before cleaning the truck with a pressure washer.
  - ▶ Do not hold the jet of the pressure washer by the marked points to avoid damaging them (see "Identification Points and Data Plates" on page 27).
  - ▶ Do not clean the truck with pressurised water.
-

## ***Cleaning the truck***

### *Requirements*

- Prepare the truck for maintenance and repairs (see "Preparing the truck for maintenance and repairs" on page 134).

### *Tools and Material Required*

- Water-based solvents
- Sponge or cloth

### *Procedure*

- Clean the surface of the truck with water-based solvents and water. Use a sponge or cloth to clean.
- In particular, clean the following areas:
  - Window(s)
  - Oil filler ports and their surroundings
  - Grease nipples (before lubrication)
- Dry the truck after cleaning, e.g. with compressed air or a dry cloth.
- Carry out all the tasks in the section "Recommissioning the truck after cleaning or maintenance work" (see "Restoring the truck to service after maintenance and repairs" on page 144).

*The truck is now clean.*

### 4.3.2 Cleaning the electrical system assemblies

#### CAUTION!

##### **Risk of electrical system damage**

Cleaning the assemblies (controllers, sensors, motors etc.) of the electronic system with water can damage the electrical system.

- ▶ Do not clean the electrical system with water.
  - ▶ Clean the electrical system with weak suction or compressed air (use a compressor with a water trap) and not a conductive, anti-static brush.
- 

##### ***Cleaning the electrical system assemblies***

###### *Requirements*

- Prepare the truck for maintenance and repairs (see "Preparing the truck for maintenance and repairs" on page 134).

###### *Tools and Material Required*

- Compressor with water separator
- Non-conductive, antistatic brush

###### *Procedure*

- Expose the electrical system, see "Front cover disassembly" on page 139.
- Clean the electrical system assemblies with weak suction or compressed air (use a compressor with a water trap) and not a conductive, anti-static brush.
- Fit the electrical system panel, see "Front cover disassembly" on page 139.
- Carry out all the tasks in the section "Recommissioning the truck after cleaning or maintenance work" (see "Restoring the truck to service after maintenance and repairs" on page 144).

*The electrical system assemblies are now clean.*

## 4.4 Front cover disassembly

### *Disassembling the panel*

#### *Procedure*

- Remove the two screws (85).
- Carefully lift off the front panel (67).

*The front panel is now disassembled.*

→ Assembly is the reverse order.

## 4.5 Drive panel disassembly and assembly

The drive panel consists of two halves (68 and 86).

### *Drive panel disassembly*

#### *Tools and Material Required*

– M5 Allen key

#### *Procedure*

- Turn the tiller to the right limit position.
- Remove 2 screws (87).
- Carefully remove the first half (68).
- Turn the tiller to the left limit position.
- Remove the second half (86) and carefully remove it.

*The drive panel has now been removed.*

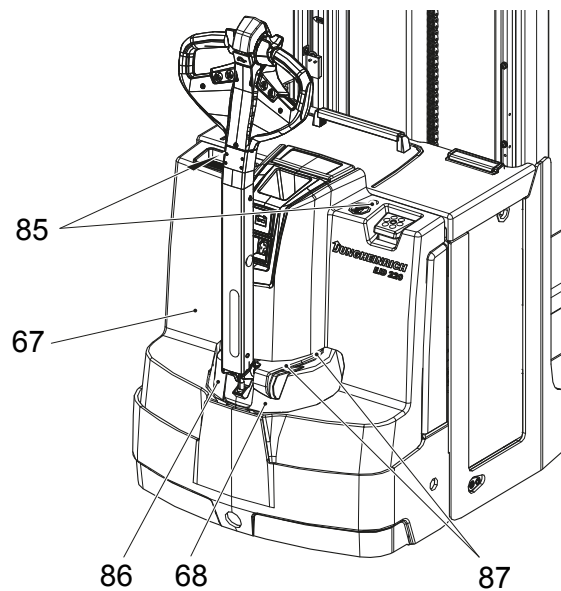

## 4.6 Checking the hydraulic oil level

### Check oil level

#### Requirements

- Lower the load handler.
- Prepare the truck for maintenance and repairs, see "Preparing the truck for maintenance and repairs" on page 134.

#### Procedure

- Lift off the front panel, see "Front cover disassembly" on page 139
- Check the oil level in the hydraulic reservoir.
- There are markings on the hydraulic reservoir. The oil level must be checked when the forks and wheel arm lift are lowered.
- If necessary add hydraulic oil of the correct grade, see "Consumables" on page 133, (see also table).
- For the first filling approximately 0.6 litres extra must be added.

*The oil level is now checked.*

- If a leak is discovered coming from the castor wheel hydraulics (castor wheel cylinder, control cylinder and from connections), the truck must be decommissioned and repaired by specialist personnel.

Mast	Capacity	Capacity New filling
DT 1055	3,2 l	3,8 l
DT 1155	3.2 l	3.8 l
DT 1205	3.2 l	3.8 l
ZT 1205	2.8 l	3.4 l
ZT 1380	2.8 l	3.4 l
ZT 1655	3.2 l	3.8 l

A = First filling

B = Max. volume

C = Min. volume

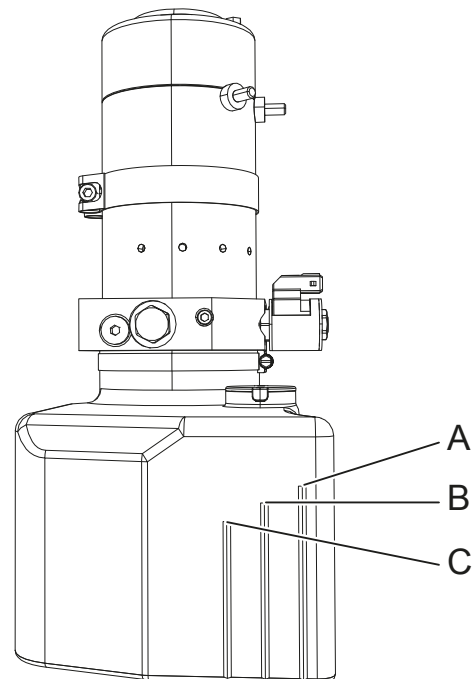

## 4.7 Check the gear oil level

### *Check the gear oil level*

#### *Requirements*

- Park the truck securely, see "Parking the truck securely" on page 63.

#### *Tools and Material Required*

- Oil sump

#### *Procedure*

- Place the oil sump underneath the transmission
- Remove the front panel (67), see "Front cover disassembly" on page 139.
- Turn the tiller to the right limit position.
- Check transmission oil level, if necessary add the right grade through the filler hole .



The oil level should reach the bottom mark of the oil dipstick .

*The transmission oil level is now checked.*

## 4.8 Tightening the wheel nuts

- The wheel nuts on the drive wheel must be retightened in accordance with the maintenance intervals indicated in the maintenance checklist, see "Servicing and Inspection" on page 148.

### *Tightening the wheel nuts*

#### *Requirements*

- Prepare the truck for maintenance and repairs, see "Preparing the truck for maintenance and repairs" on page 134.

#### *Tools and Material Required*

- Torque wrench

#### *Procedure*

- Position the drive wheel (88) so that the wheel nuts (89) can be pulled through the hole (90).
- Tighten all the wheel nuts (89) through the hole (90) in the impact buffer with the socket wrench.

To do this, tighten the wheel nuts in the prescribed order.

- First of all tighten to 10 Nm.
- and then to 150 Nm.

*The wheel nuts have now been tightened.*

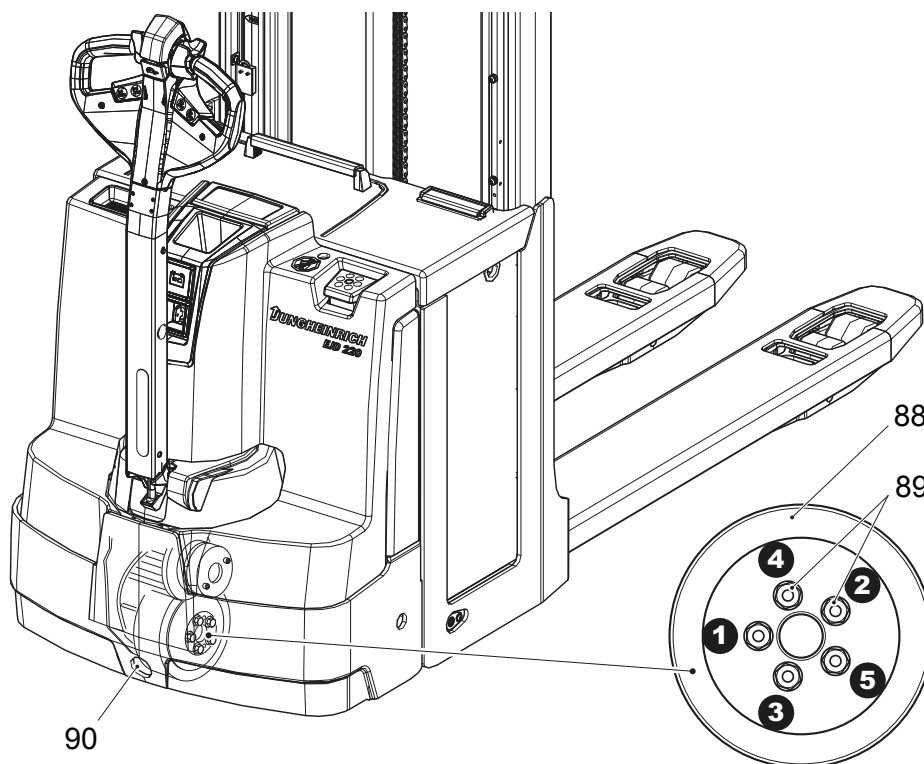

## 4.9 Checking electrical fuses

### Check fuses

#### Requirements

- Truck prepared for maintenance and repairs, see "Preparing the truck for maintenance and repairs" on page 134.
- Front cover removed, see "Front cover disassembly" on page 139.

#### Procedure

- Check the fuse ratings against the table and replace if necessary.

*The fuses are now checked.*

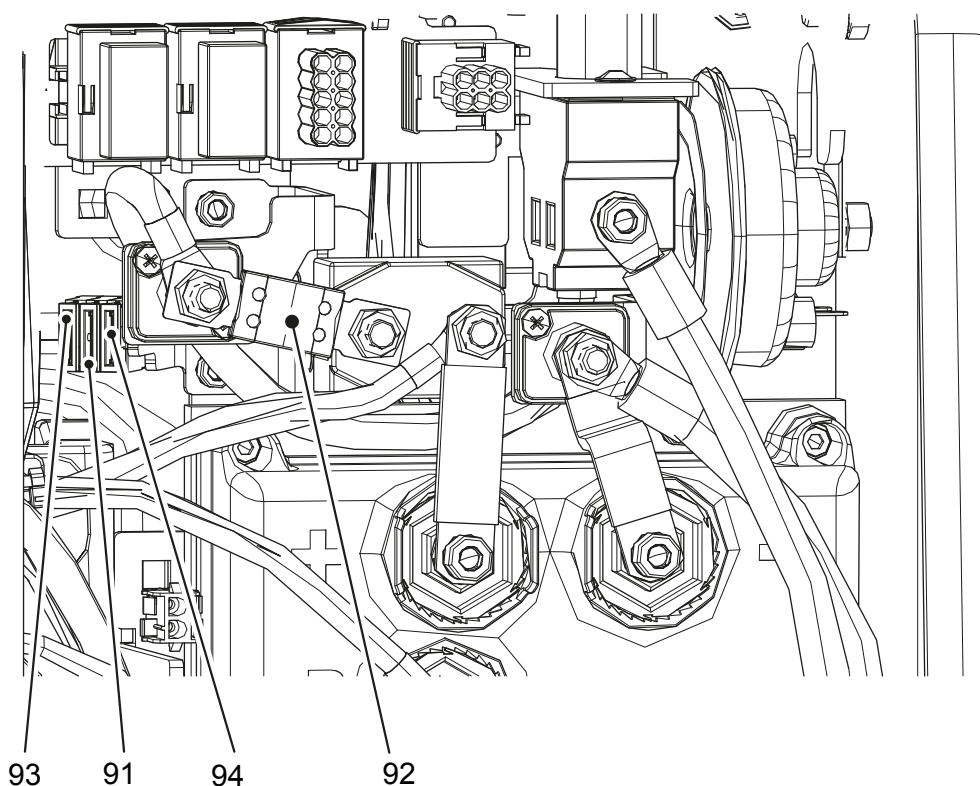

Item	Component	To protect	EJD 220
93	6F1	Discharge indicator control fuse	2 A
91	1F9	Electronic system control fuse	10 A
94	F13	Solenoid / magnetic brake control fuse	10 A
92	F 1	Travel / lift fuse	200 A



## 4.10 Restoring the truck to service after maintenance and repairs

### *Procedure*

- Thoroughly clean the truck, see page 136.
- Lubricate the truck according to the lubrication diagram, see page 132.
- Clean the battery, grease the terminals and connect the battery.
- Charge the battery, see page 41.
- Start up the truck, see page 60.

## 5 Decommissioning the Industrial Truck

If the truck is to be out of service for more than a month, it must be stored in a frost-free and dry room. All necessary measures must be taken before, during and after decommissioning as described hereafter.

When the truck is out of service it must be jacked up so that all the wheels are clear of the ground. This is the only way of ensuring that the wheels and wheel bearings are not damaged.

→ Jack up the truck, see "Lifting and jacking up the truck safely" on page 135.

If the truck is to be out of service for more than 6 months, agree further measures with the manufacturer's customer service department.

### 5.1 Prior to decommissioning

#### *Procedure*

- Thoroughly clean the truck, see "Cleaning" on page 136.
- Prevent the truck from rolling away accidentally.
- Check the hydraulic oil level and replenish if necessary, see "Checking the hydraulic oil level" on page 140.
- Apply a thin layer of oil or grease to any non-painted mechanical components.
- Lubricate the truck according to the lubrication schedule, see "Lubrication Schedule" on page 132.
- Charge the battery, see "Charging the battery" on page 41.
- Disconnect the battery, clean it and grease the terminals.

→ In addition, follow the battery manufacturer's instructions.

### 5.2 Action to be taken during decommissioning

#### **NOTE**

#### **Full discharge can damage the battery**

Self-discharge can cause the battery to fully discharge. Full discharge shortens the useful life of the battery.

► Charge the battery at least every 2 months.

---

→ Charge the battery, see "Charging the battery" on page 41.

### 5.3 Restoring the truck to service after decommissioning

#### *Procedure*

- Thoroughly clean the truck, see "Cleaning" on page 136.
- Lubricate the truck according to the lubrication schedule, see "Lubrication Schedule" on page 132.
- Clean the battery, grease the terminals and connect the battery.
- Charge the battery, see "Charging the battery" on page 41.
- Replace transmission oil. Condensation water could have formed.
- Replace hydraulic oil. Condensation water could have formed.
- ➔ The manufacturer's customer service department is specially trained to carry out these operations.
- Start up the truck, see "Preparing the Truck for Operation" on page 60.

## **6 Safety tests to be performed at intervals and after unusual incidents**

The truck must be inspected at least annually (refer to national regulations) or after any unusual event by a qualified inspector. The manufacturer offers a safety inspection service which is performed by personnel specifically trained for this purpose.

A complete test must be carried out on the technical condition of the truck with regard to safety. The truck must also be examined thoroughly for damage.

The operating company is responsible for ensuring that faults are rectified immediately.

## **7 Final de-commissioning, disposal**

→ Final de-commissioning or disposal of the truck in must be performed in accordance with the regulations of the country of use. In particular, regulations governing the disposal of batteries, consumables and electronic and electrical systems must be observed.

The truck must only be disassembled by trained personnel in accordance with the procedures as specified by the manufacturer.

## **8 Human vibration measurement**

→ Vibrations that affect the operator over the course of the day are known as human vibrations. Excessive human vibrations will cause the operator long term health problems. The European "2002/44/EC/Vibration" operator directive has therefore been established to protect operators. To help operators to assess the application situation, the manufacturer offers a service of measuring these human vibrations.

## 9 Servicing and Inspection

### **WARNING!**

#### **Lack of maintenance can result in accidents**

Failure to perform regular servicing can lead to truck failure and poses a potential hazard to personnel and equipment.

► Thorough and expert servicing is one of the most important requirements for the safe operation of the industrial truck.

---

The application conditions of an industrial truck have a considerable impact on component wear. The following service intervals are based on single-shift operation under normal operating conditions. They must be reduced accordingly if the equipment is to be used in conditions of extreme dust, temperature fluctuations or multiple shifts.

### **NOTE**

To prevent damage due to wear, the manufacturer recommends an on-site application analysis to agree on appropriate service intervals.

---

The following maintenance checklist lists the activities to be performed and the respective intervals to be observed. Maintenance intervals are defined as:

- W = Every 50 service hours, at least weekly
- A = Every 500 service hours
- B = Every 1000 service hours, or at least annually
- C = Every 2000 service hours, or at least annually
- = Standard maintenance interval
- \* = Cold store maintenance interval (in addition to standard maintenance interval)

 "W" maintenance interval operations should be performed by the operating company.

During the run-in period, after approx. 100 service hours, the owner must check the wheel nuts/bolts and re-tighten if necessary.

# 10 Maintenance checklist

## 10.1 Operating company

### 10.1.1 Standard equipment

<b>Brakes</b>		<b>W</b>	<b>A</b>	<b>B</b>	<b>C</b>
1	Test brakes.	●			

<b>Electrical System</b>		<b>W</b>	<b>A</b>	<b>B</b>	<b>C</b>
1	Test warning and safety devices in accordance with operating instructions.	●			
2	Test displays and controls.	●			
3	Test Emergency Disconnect switch.	●			

<b>Power Supply</b>		<b>W</b>	<b>A</b>	<b>B</b>	<b>C</b>
1	Check battery cable connections are secure, grease terminals if necessary.	●			
2	Check battery and battery components.	●			
3	Check battery connector for damage, test it and make sure it is secure.	●			

<b>Travel</b>		<b>W</b>	<b>A</b>	<b>B</b>	<b>C</b>
1	Check wheels for wear and damage.	●			

<b>Chassis and Superstructure</b>		<b>W</b>	<b>A</b>	<b>B</b>	<b>C</b>
1	Check doors and/or covers.	●			
2	Check labels are legible and complete.	●			
3	Check mast protection pane / mast grille for damage.	●			

<b>Hydraulic operations</b>		<b>W</b>	<b>A</b>	<b>B</b>	<b>C</b>
1	Check load chain lubrication and lubricate if necessary.	●			
2	Test hydraulic system.	●			
3	Check hydraulic oil level and top up if necessary.	●			
4	Check forks or load handler for wear and damage.	●			

<b>Steering</b>		<b>W</b>	<b>A</b>	<b>B</b>	<b>C</b>
1	Check tiller return function.	●			

## 10.1.2 Optional equipment

### Electrolyte recirculation

<b>Power Supply</b>		<b>W</b>	<b>A</b>	<b>B</b>	<b>C</b>
1	Check hose connections and test the pump.	*			

## 10.2 Customer Service

### 10.2.1 Standard equipment

<b>Brakes</b>		<b>W</b>	<b>A</b>	<b>B</b>	<b>C</b>
1	Test brakes.			●	
2	Check the air gap of the magnetic brake.			●	

<b>Electrical System</b>		<b>W</b>	<b>A</b>	<b>B</b>	<b>C</b>
1	Check cables and motor mounting are secure.			●	
2	Test warning and safety devices in accordance with operating instructions.			●	
3	Test displays and controls.			●	
4	Test Emergency Disconnect switch.			●	
5	Check contactors and/or relays.			●	
6	Check fuse ratings.			●	
7	Check carbon brushes and replace if necessary. Note: when replacing the carbon brushes apply compressed air to the motor.			●	
8	Carry out a frame leakage test.			●	
9	Check electrical wiring for damage (insulation damage, connections). Make sure wire connections are secure.			●	

<b>Power Supply</b>		<b>W</b>	<b>A</b>	<b>B</b>	<b>C</b>
1	Check battery cable connections are secure, grease terminals if necessary.			●	
2	Check battery and battery components.			●	
3	Check acid density and battery voltage.			●	
4	Check battery connector for damage, test it and make sure it is secure.			●	

<b>Travel</b>		<b>W</b>	<b>A</b>	<b>B</b>	<b>C</b>
1	Check drivetrain mountings and bearings.			●	
2	Check transmission for noise and leakage.			●	
3	Note: Replace transmission oil after 10000 service hours.				
4	Check wheels for wear and damage.			●	
5	Check wheel suspension and attachment.			●	
6	Test coupling unit cylinders and check for leaks.			●	



<b>Chassis and Superstructure</b>		<b>W</b>	<b>A</b>	<b>B</b>	<b>C</b>
1	Check chassis and screw connections for damage.			●	
2	Check doors and/or covers.			●	
3	Check labels are legible and complete.			●	
4	Check mast attachment / mounting.			●	
5	Check mast protection pane / mast grille for damage.			●	

<b>Hydraulic operations</b>		<b>W</b>	<b>A</b>	<b>B</b>	<b>C</b>
1	Test "hydraulic" controls and make sure the labels are present, legible and complete.			●	
2	Test the lift sensors in the mast and initial lift and check for damage.			●	
3	Check cylinders and piston rods for damage and leaks, and make sure they are secure.			●	
4	Check settings and wear levels of slide pieces and stops and adjust the slide pieces if necessary.			●	
5	Check load chain setting and tension if necessary.			●	
6	Check load chain lubrication and lubricate if necessary.			●	
7	Check lateral clearance of the mast connections and the fork carriage.			●	
8	Visually inspect the mast rollers and check contact surface wear level.			●	
9	Test hydraulic system.			●	
10	Replace hydraulic oil filter, ventilation/discharge filter.			*	●
11	Check that hydraulic ports, hose and pipe lines are secure, check for leaks and damage.			●	
12	Test emergency lowering system.			●	
13	Check hydraulic oil level and top up if necessary.			●	
14	Test pressure relief valve and adjust if necessary.			●	
15	Replace hydraulic oil.			*	●
16	Check forks or load handler for wear and damage.			●	
17	Check tie/plunger rods.			●	
18	Test lift and lowering speeds.			●	

<b>Agreed services</b>		<b>W</b>	<b>A</b>	<b>B</b>	<b>C</b>
1	Carry out a test run with rated load, if necessary with a customer-specific load.			●	
2	Lubricate truck according to the lubrication schedule.			●	
3	Demonstration after servicing.			●	

<b>Steering</b>		<b>W</b>	<b>A</b>	<b>B</b>	<b>C</b>
1	Check tiller return function.			●	

## 10.2.2 Optional equipment

### Aquamatik

Power Supply		W	A	B	C
1	Test Aquamatik plug, hose connections and float and check for leaks.			●	
2	Test flow indicator and check for leaks.			●	

### Battery refill system

Power Supply		W	A	B	C
1	Test battery refill system and check for leaks.			●	

### Data recorder

Electrical System		W	A	B	C
1	Check data recorder is secure and check for damage.			●	

### Standard on-board charger

Charger		W	A	B	C
1	Check mains plug and mains cable.			●	
2	Test the immobiliser on trucks with an on-board charger.			●	
3	Check the wires and electrical connections are secure and not damaged.			●	
4	Carry out potential measurement on chassis while charging is in progress.			●	

### Electrolyte recirculation

Power Supply		W	A	B	C
1	Replace air filter wadding.			●	
2	Check hose connections and test the pump.			●	

### Load backrest

Hydraulic operations		W	A	B	C
1	Check attachment is properly secured to the truck and check the load-bearing components.			●	

### Impact sensor

Electrical System		W	A	B	C
1	Check impact sensor is secure and check for damage.			●	

## Access module

Electrical System		W	A	B	C
1	Test access module, check for damage and make sure it is secure.			●	

Issued on: 27.05.2013 08:24:37

# A Traction Battery Appendix

## Contents

A	Traction Battery Appendix.....	1
1	Correct Use and Application.....	2
2	Data plate.....	2
3	Safety Instructions, Warning Indications and other Notes.....	3
4	Lead acid batteries with armour plated cells and liquid electrolyte.....	4
4.1	Description.....	4
4.2	Operation.....	5
4.3	Servicing lead-acid batteries with armour plated cells.....	8
5	PzV and PzV-BS lead-acid batteries with sealed armour plated cells.....	9
5.1	Description.....	9
5.2	Operation.....	10
5.3	Servicing PzV and PzV-BS lead-acid batteries with sealed armour plated cells.....	13
6	Aquamatik water replenishment system.....	14
6.1	Water replenishment system design.....	14
6.2	Functional Description.....	15
6.3	Adding water.....	15
6.4	Water pressure.....	15
6.5	Filling time.....	16
6.6	Water quality.....	16
6.7	Battery tubing.....	16
6.8	Operating temperature.....	16
6.9	Cleaning measures.....	17
6.10	Service mobile vehicle.....	17
7	Electrolyte circulation.....	18
7.1	Functional Description.....	18
8	Cleaning batteries.....	20
9	Storing the battery.....	22
10	Troubleshooting.....	22
11	Disposal.....	22

# 1 Correct Use and Application

Failure to observe the operating instructions, carrying out repairs with non-original spare parts, tampering with the battery or using electrolyte additives will invalidate the warranty.







Observe the instructions for maintaining the safety rating during operation for batteries in accordance with Ex I and Ex II (see relevant certification).

# 2 Data plate

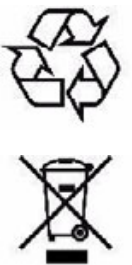
1,2	Typ type	<b>48 V 5 PzS 775</b>	Produktionswoche/-jahr Week/Year of Manufacture	<b>40/2012</b>	3
4	Serien-Nr. Serial-No	<b>80882194</b>	Lieferanten Nr. Supplier-No	<b>17769</b>	5
6	Nennspannung Nominal Voltage	<b>48 V</b>	Kapazität C5 Capacity C5	<b>775 Ah</b>	7
8	Zellenanzahl Number of Cells	<b>24</b>	Gewicht ± 5% Weight ± 5%	<b>1118 kg</b>	9
10	Sachnummer Part-No	<b>50297157</b>	Säuremenge Acid volume	<b>189,4 l</b>	15
11	Hersteller Manufacturer	<b>Jungheinrich AG, 22039 HAMBURG, GERMANY</b>			
12		<b>JUNGHEINRICH</b>			13
					14

1	Battery name
2	Battery type
3	Production week/year manf.
4	Serial number
5	Supplier number
6	Rated voltage
7	Rated capacity
9	Battery weight in kg
8	Number of cells
15	Electrolyte volume in litres
10	Battery number
11	Manufacturer
13	Manufacturer's logo
12	CE mark only for batteries beyond 75 volts
14	Safety instructions and warning information

### 3 Safety Instructions, Warning Indications and other Notes

	<p>Used batteries must be treated as hazardous waste.</p> <p>These batteries are marked with the recycling symbol and the sign showing a crossed-out rubbish bin, and should not be disposed of with ordinary household waste.</p> <p>Buy-back terms and type of recycling are to be agreed with the manufacturer as described in § 8 of the battery legislation.</p>
	<p>Do not smoke!</p> <p>No naked flames, glowing embers or sparks near the battery - fire and explosion hazard!</p>
	<p>Avoid fire and explosion hazards and short circuits due to overheating!</p> <p>Keep away from naked flames and strong heat sources.</p>
	<p>Always wear protective clothing (e.g. safety goggles and safety gloves) when working on cells and batteries.</p> <p>Always wash your hands after completing the work. Use insulated tools only. Do not physically alter the battery, strike, crush, compress, notch, dent or modify it in any way.</p>
	<p>Hazardous electric voltage! The metal parts of the battery cells are permanently live. Therefore do not place any foreign objects or tools on the battery.</p> <p>Observe national health and safety regulations.</p>
	<p>If the materials leak, do not inhale the fumes. Wear safety gloves.</p>
	<p>Follow the user instructions and keep them in a visible position in the charging area.</p> <p>Work on the batteries should be performed only as instructed by specialist personnel.</p>

## 4 Lead acid batteries with armour plated cells and liquid electrolyte

### 4.1 Description

Jungheinrich traction batteries are lead acid batteries with armour plated cells and liquid electrolyte. The names of the traction batteries are PzS, PzB, PzS Lib and PzM.

#### Electrolyte

The rated density of the electrolyte assumes a temperature of 30°C and the rated electrolyte level is fully charged. Higher temperatures will reduce, lower temperatures will increase the electrolyte density. The adjustment factor is  $\pm 0.0007$  kg/l per K, e.g. electrolyte density 1.28 kg/l at 45°C corresponds to a density of 1.29 kg/l at 30°C.

The electrolyte must conform to DIN 43530 Part 2 purity regulations.

#### 4.1.1 Battery nominal data

1.	Product	Traction battery
2.	Nominal voltage	2.0 V x no. of cells
3.	Rated capacity C5	See data plate
4.	Discharge current	C5/5h
5.	Nominal electrolyte density <sup>1</sup>	1.29 kg/l
6.	Nominal temperature <sup>2</sup>	30 °C
7.	System rated electrolyte level	up to "Max" electrolyte level marking
	Limit temperature <sup>3</sup>	55°C

1. Reached within the first 10 cycles.
2. Higher temperatures shorten the useful life, lower temperatures reduce the available capacity.
3. Not permissible as operating temperature.

## 4.2 Operation

### 4.2.1 Commissioning unfilled batteries

- The operations required must be carried out by the manufacturer's customer service department or a customer service organisation authorised by the manufacturer.

### 4.2.2 Commissioning filled and charged batteries

#### ***Checks and operations to be performed before starting daily work***

##### *Procedure*

- Make sure the battery is in physically good condition.
- Make sure the terminals are correct (positive to positive and negative to negative) and check that contacts on the battery terminal conducting system are secure.
- Check the terminal screw torques (M10 =  $23 \pm 1$  Nm) of the terminal conductors and connectors.
- Charge up the battery.
- Check the electrolyte level.
- The electrolyte level must be above the cell baffle or the top of the separator.
- Add electrolyte with distilled water up to the nominal level.

*Checks completed.*

### 4.2.3 Discharging the battery

- To achieve an optimum useful life avoid operational discharge of more than 80% of nominal capacity (full discharge). This corresponds to a minimum electrolyte density of 1.13 kg/l at the end of the discharge. Recharge a discharged battery immediately.



#### 4.2.4 Charging the battery

##### **WARNING!**

##### **The gases produced during charging can cause explosions**

The battery gives off a mixture of oxygen and hydrogen (electrolytic gas) during charging. Gassing is a chemical process. This gas mixture is highly explosive and must not be ignited.

- ▶ Always disconnect the charger and truck before connecting or disconnecting the charger and battery.
- ▶ The charger must be adapted to the battery in terms of voltage, charge capacity and battery technology.
- ▶ Before charging, check all cables and plug connections for visible signs of damage.
- ▶ Ventilate the room in which the truck is being charged.
- ▶ Battery cell surfaces must remain exposed during charging in order to ensure sufficient ventilation, see truck operating instructions, chapter D, Charging the Battery.
- ▶ Do not smoke and avoid naked flames when handling batteries.
- ▶ Wherever an industrial truck is parked for charging there must be no inflammable material or consumables capable of creating sparks within a minimum distance of 2 m from the truck.
- ▶ Fire protection equipment must be available.
- ▶ Do not place any metallic objects on the battery.
- ▶ Always follow the safety regulations of the battery and charger station manufacturers.

---

##### **NOTE**

**The battery must only be charged with DC current. All charging processes in accordance with DIN 41773 and DIN 41774 are permissible.**

---

- The electrolyte temperature rises by approx. 10 K during charging. Charging should therefore only begin when the electrolyte temperature is below 45°C. The electrolyte temperature of batteries must be at least +10°C before charging. Otherwise the battery will not charge correctly. Below 10°C the battery is insufficiently charged with standard charging systems.

### **Charging the battery**

#### *Requirements*

- Electrolyte temperature min. 10°C to max. 45°C

#### *Procedure*

- Open or take off the tray lid or covers from the battery compartment.
- Deviations are outlined in the truck's operating instructions. The plugs remain on the cells or remain closed.
- Connect the battery to the switched off charger, ensuring the terminals are connect (positive to positive and negative to negative).
  - Switch on the charger.

#### *Battery charged*

- *Charging is considered to be complete when the electrolyte density and battery voltage remain constant for more than 2 hours.*

### **Compensation charging**

Compensation charging is used to ensure the useful life and maintain capacity after full discharge and repeated insufficient charging. The maximum compensation charge current is 5 A/100 Ah rated capacity.

- Compensation charging should be carried out weekly.

### **Trickle charging**

Battery trickle charging is partial charging that extends the daily application time. Higher average temperatures occur during trickle charging which reduce the useful life of the batteries.

- Trickle charges should only be performed when the charge level is below 60 %. Use replacement batteries instead of regular trickle charging.

## 4.3 Servicing lead-acid batteries with armour plated cells

### Water quality

- The quality of the water used to fill up electrolyte must correspond to purified or distilled water. Purified water can be produced through distillation or ion exchangers and is then suitable for the production of electrolyte.

#### 4.3.1 Daily

- Charge the battery after each discharge.
- After charging, check the electrolyte level.
- If necessary, add purified water up to the rated level after charging.

- The height of the electrolyte level should not be below the cell baffle or above the top of the separator, or the "Min" and "Max" electrolyte markings respectively.

#### 4.3.2 Weekly

- After re-charging, carry out a visual inspection for dirt and physical damage.
- If the battery is charged regularly according to the IU characteristic, carry out a compensation charge.

#### 4.3.3 Monthly

- Towards the end of the charging process measure and record the voltages of all the cells with the charger switched on.
- After charging measure and record the electrolyte density and the electrolyte temperature in all the cells.
- Compare the results with the previous ones.

- If you find significant differences compared with the previous measurements or differences between the cells, contact the manufacturer's customer service department.

#### 4.3.4 Annually

- Measure the truck insulation resistance in accordance with EN 1175-1.
- Measure the battery insulation resistance in accordance with EN 1987-1.

- In accordance with DIN EN 50272-3 the battery insulation resistance should not be less than 50  $\Omega$  per volt of rated voltage.

## 5 PzV and PzV-BS lead-acid batteries with sealed armour plated cells

### 5.1 Description

PzV batteries are sealed batteries with fixed electrolytes, to which no water can be added over the entire lifespan of the battery. Relief valves are used as plugs which are destroyed when opened. During operation the same safety requirements apply to the sealed batteries as for batteries with liquid electrolyte. This is to avoid electric shock, explosion of the electrolyte charging gases or hazardous electrolyte burns if the cell vessels are destroyed.

→ PzV batteries are low gassing, but not gassing-free.

#### Electrolyte

The electrolyte is sulphuric acid which is fixed in gel. The density of the electrolyte cannot be measured.

#### 5.1.1 Battery nominal data

1.	Product	Traction battery
2.	Nominal voltage	2.0 V x no. of cells
3.	Rated capacity C5	See data plate
4.	Discharge current	C5/5h
5.	Rated temperature	30 °C
	Limit temperature <sup>1</sup>	45°C, not permissible as operating temperature.
6.	Rated density of the electrolyte	Cannot be measured
7.	System rated electrolyte level	Cannot be measured

1. Higher temperatures shorten the useful life, lower temperatures reduce the available capacity.

## 5.2 Operation

### 5.2.1 Commissioning

#### ***Checks and operations to be performed before starting daily work***

##### *Procedure*

- Make sure the battery is in physically good condition.
- Make sure the terminals are correct (positive to positive and negative to negative) and check that contacts on the battery terminal conducting system are secure.
- Check the terminal screw torques (M10 =  $23 \pm 1$  Nm) of the terminal conductors and connectors.
- Re-charge the battery.
- Charge the battery.

*Check completed.*

### 5.2.2 Discharging the battery

- To achieve an optimum useful life avoid operational discharges of more than 60% of nominal capacity.
- If the battery is discharged during operation by more than 80% of rated capacity the useful life of the battery will reduce significantly. Fully or partially discharged batteries must be re-charged immediately and not left unattended.

### 5.2.3 Charging the battery

#### **⚠ WARNING!**

##### **The gases produced during charging can cause explosions**

The battery gives off a mixture of oxygen and hydrogen (electrolytic gas) during charging. Gassing is a chemical process. This gas mixture is highly explosive and must not be ignited.

- ▶ Always disconnect the charger and truck before connecting or disconnecting the charger and battery.
- ▶ The charger must be adapted to the battery in terms of voltage, charge capacity and battery technology.
- ▶ Before charging, check all cables and plug connections for visible signs of damage.
- ▶ Ventilate the room in which the truck is being charged.
- ▶ Battery cell surfaces must remain exposed during charging in order to ensure sufficient ventilation, see truck operating instructions, chapter D, Charging the Battery.
- ▶ Do not smoke and avoid naked flames when handling batteries.
- ▶ Wherever an industrial truck is parked for charging there must be no inflammable material or consumables capable of creating sparks within a minimum distance of 2 m from the truck.
- ▶ Fire protection equipment must be available.
- ▶ Do not place any metallic objects on the battery.
- ▶ Always follow the safety regulations of the battery and charger station manufacturers.

## NOTE

### **Charging the battery incorrectly can result in material damage.**

Incorrect battery charging can result in overloading of the electric wires and contacts, hazardous gas formation and electrolyte leakage from the cells.

- ▶ Always charge the battery with DC current.
  - ▶ All DIN 41773 charging procedures are permitted in the format approved by the manufacturer.
  - ▶ Always connect the battery to a charger that is appropriate to the size and type of the battery.
  - ▶ If necessary have the charger checked by the manufacturer's customer service department for suitability.
  - ▶ Do not exceed limit currents in the gassing area in accordance with DIN EN 50272-3.
-

## **Charging the battery**

### *Requirements*

- Electrolyte temperature between +15°C and 35°C

### *Procedure*

- Open or take off the tray lid or covers from the battery compartment.
  - Connect the battery to the switched off charger, ensuring the terminals are connect (positive to positive and negative to negative).
  - Switch on the charger.
- The electrolyte temperature rises by approx. 10 K during charging. If the temperatures are permanently higher than 40°C or lower than 15°C, a temperature-dependent constant voltage control of the charger is required. The adjustment factor must be applied with -0.004 V/C per K.

### *Battery charged*

- *Charging is considered to be complete when the electrolyte density and battery voltage remain constant for more than 2 hours.*

## **Compensation charging**

Compensation charging is used to ensure the useful life and maintain capacity after full discharge and repeated insufficient charging.

- Compensation charging should be carried out weekly.

## **Trickle charging**

Battery trickle charging is partial charging that extends the daily application time. Higher average temperatures occur during trickle charging which can reduce the useful life of the batteries.

- Trickle charges should only be performed when the charge level is below 50%. Use replacement batteries instead of regular trickle charging.
- Avoid trickle charging with PzV batteries.

### 5.3 Servicing PzV and PzV-BS lead-acid batteries with sealed armour plated cells

→ Do not add water!

#### 5.3.1 Daily

– Charge the battery after each discharge.

#### 5.3.2 Weekly

– Visually inspect for dirt and physical damage.

#### 5.3.3 Every three months

- Measure and record the overall voltage.
- Measure and record the individual voltages.
- Compare the results with the previous ones.

→ Carry out the measurements after full charging and subsequent resting for at least 5 hours.

→ If you find significant differences compared with the previous measurements or differences between the cells, contact the manufacturer's customer service department.

#### 5.3.4 Annually

- Measure the truck insulation resistance in accordance with EN 1175-1.
- Measure the battery insulation resistance in accordance with EN 1987-1.

→ In accordance with DIN EN 50272-3 the battery insulation resistance should not be less than 50  $\Omega$  per volt of rated voltage.



## 6 Aquamatik water replenishment system

### 6.1 Water replenishment system design

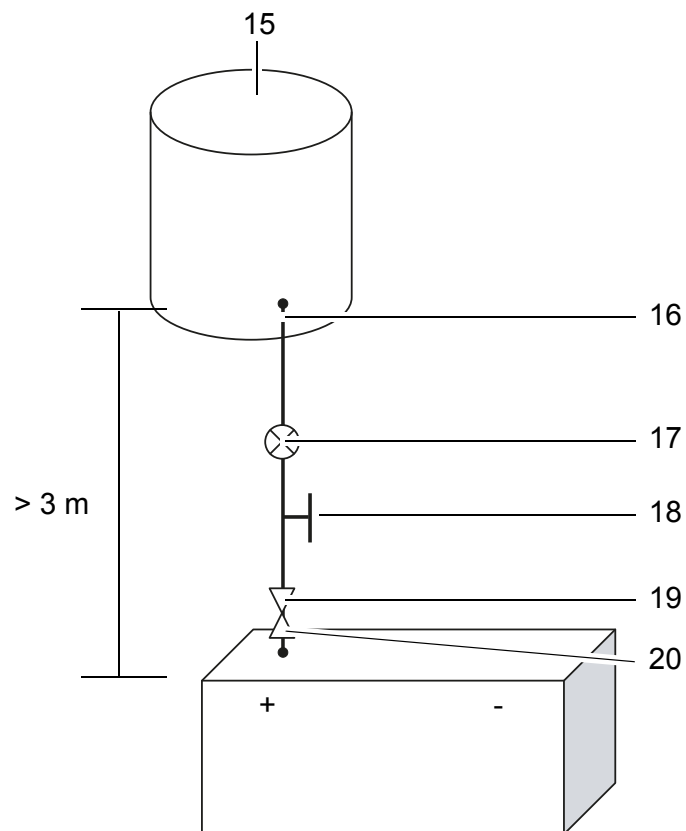

15	Water container
16	Tap connection with ball cock
17	Flow indicator
18	Shut-off cock
19	Locking coupling
20	Battery lock connector

## 6.2 Functional Description

The Aquamatik water replenishment system is used to adjust the rated electrolyte level automatically on traction batteries for industrial trucks.

The battery cells are interconnected through hoses and are attached to the water supply (e.g. water container) through a plug connection. When the shut-off cock is opened all the cells are filled with water. The Aquamatik plug controls the amount of water required and, at the relevant water pressures, ensures the water supply is shut off and the valve is closed securely.

The plug systems have an optical level indicator, a diagnostic port to measure the temperature and electrolyte density and a degassing port.

## 6.3 Adding water

Water should be added to the batteries just before the battery is fully charged. This ensures that the amount of water added is mixed with the electrolyte.

## 6.4 Water pressure

The water replenishment system must be operated with a water pressure in the water line of 0.3 bar - 1.8 bar. Any deviations from the permissible pressure ranges will affect the operation of the systems.

### Water drop

Assembly height above battery surface is between 3 - 18 m. 1 m corresponds to 0.1 bar

### Pressure water

The pressure regulating valve is adjusted to suit the system and must lie between 0.3 - 1.8 bar.

## 6.5 Filling time

The filling time for a battery depends on the electrolyte level, the ambient temperature and the filling pressure. Filling ends automatically. The water supply line must be disconnected from the battery when the water has been filled.

## 6.6 Water quality

- The quality of the water used to fill up electrolyte must correspond to purified or distilled water. Purified water can be produced through distillation or ion exchangers and is then suitable for the production of electrolyte.

## 6.7 Battery tubing

The tubing of the individual plugs is in accordance with the existing electric circuit. No changes should be made.

## 6.8 Operating temperature

Batteries with automatic water replenishment systems should only be stored in rooms with temperatures  $> 0^{\circ}\text{C}$ , as otherwise the systems could freeze.

## **6.9 Cleaning measures**

The plug systems must only be cleaned with purified water in accordance with DIN 43530-4. No parts of the plugs must come into contact with solvent-based materials or soap.

## **6.10 Service mobile vehicle**

Mobile water filling vehicle with pump and filling gun to fill individual cells. The immersion pump in the container generates the necessary filling pressure. The service mobile must be at exactly the same height as the battery base.

## **7 Electrolyte circulation**

### **7.1 Functional Description**

Electrolyte circulation ensures the supply of air during charging to mix the electrolyte, thereby preventing any acid layer, shortening the charge time (charge factor approx. 1.07) and reducing the formation of gas during charging. The charger must be suitable for the battery and electrolyte circulation.

A pump in the charger produces the necessary compressed air which is introduced to the battery cells via a hose system. The electrolyte is circulated via the inlet air and the electrolyte density level is constant over the entire length of the electrode.

#### **Pump**

In the event of a fault, e.g. if the pressure control system responds for an unknown reason, the filters must be checked and replaced if necessary.

#### **Battery connection**

A hose is attached to the pump module which together with the charge leads is routed from the charger to the charging connector. The air is passed on to the battery via the electrolyte circulation coupling ducts in the connector. When routing make sure the hose is not bent.

#### **Pressure monitoring module**

The electrolyte circulation pump is activated when charging begins. The pressure monitoring module monitors the build up of pressure during charging. This ensures that the required air pressure is provided for electrolyte circulation charging.

In the event of malfunctions such as:

- Battery air coupling not connected to circulation module (if coupling is separate) or faulty.
- Leaky or faulty hose connections on battery or
- Intake filter contaminated

a visual error message appears on the charger.

## NOTE

If an installed electrolyte circulation system is seldom used or not used at all, or if the battery is subjected to severe temperature fluctuations, the electrolyte may flow back into the hose system.

- ▶ Attach a separate coupling system to the air inlet line, such as: locking coupling on the battery side and through-coupling on the air supply side.

## Schematic illustration

Electrolyte circulation on the battery and air supply via the charger.

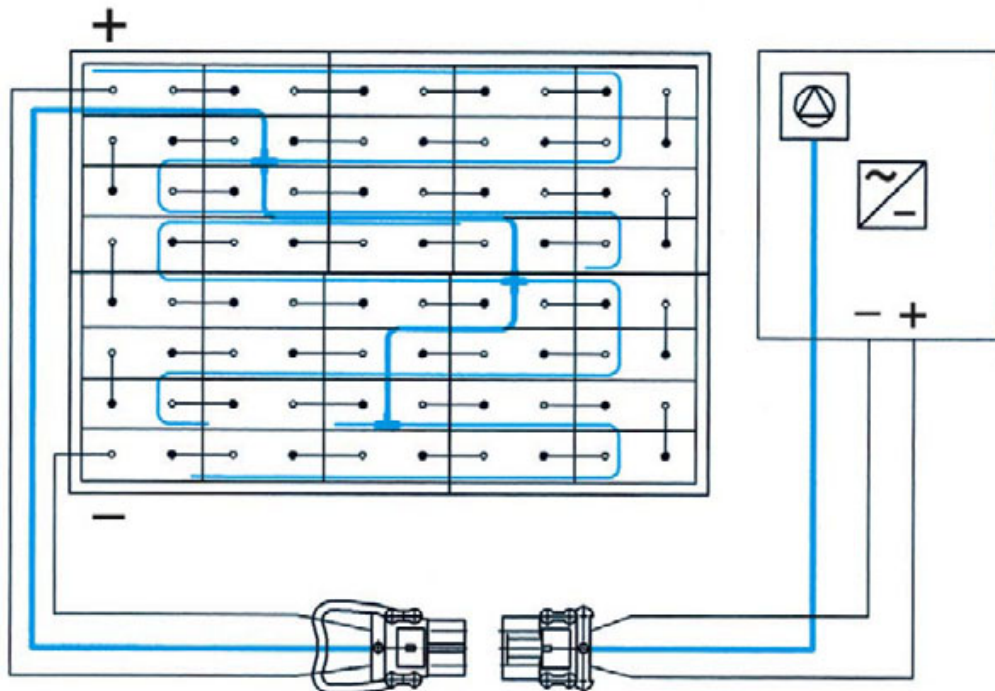

## 8 Cleaning batteries

Batteries and trays must be cleaned in order to

- maintain cell insulation and protect cells from ground or external conductive parts.
- Avoid damage from corrosion and stray currents.
- Avoid excessive and varying automatic discharge of the individual cells or block batteries due to stray currents.
- Avoid electric sparking due to stray currents.

When cleaning the batteries make sure that:

- The assembly site chosen for cleaning is close to a drainage system for processing the electrolytic rinsing water.
- All health and safety as well as water and waste disposal regulations are observed when disposing of used electrolyte or rinsing water.
- Protective goggles and clothing are worn.
- Cell plugs are not removed or opened.
- Clean the plastic components of the battery, in particular the cell containers, only with water or water-based cloths without any additives.
- After cleaning, the top of the battery is dried with suitable equipment, e.g. compressed air or cloths.
- Any fluid that has entered the battery box must be suctioned off and disposed of in accordance with the above-mentioned regulations.

## ***Cleaning the battery with a high pressure cleaner***

### ***Requirements***

- Cell connectors tight, plugged in securely
- Cell plugs closed

### ***Procedure***

- Follow the high pressure cleaner's user instructions.
- Do not use any cleaning additives.
- Observe the permissible cleaning device temperature setting of 140°C.
- ☞ This generally ensures that the temperature does not exceed 60°C at a distance of 30cm behind the outlet nozzle.
- Observe the maximum operating pressure of 50 bar.
- Observe a minimum distance of 30 cm from the top of the battery.
- The battery should be sprayed over its entire surface to avoid localised overheating.
- ☞ Do not clean one spot for more than 3 seconds with the jet to avoid exceeding the maximum battery surface temperature of 60°C.
- After cleaning dry the battery surface with suitable materials e.g. compressed air or cleaning cloths.

***Battery cleaned.***



## 9 Storing the battery

### NOTE

The battery should not be stored for longer than 3 months without charging as otherwise it will no longer be functional.

---

If the battery is to be taken out of service for a long period, it should be stored fully charged in a dry room protected from frost. To ensure the availability of the battery the following charges can be selected:

- Monthly compensation charge for PzS and PzB batteries or 3-monthly full charge for PzV batteries.
- Trickle charge for a charge voltage of 2.23 volts x no. of cells for PzS, PzM and PzB batteries or 2.25 volts x no. of cells for PzV batteries.

If the battery is to be taken out of service for a long period (> 3 months), it should, as far as possible, be charged to 50% of its charge level and stored in a dry room protected from frost.

## 10 Troubleshooting

If any faults are found on the battery or charger, contact the manufacturer's customer service department immediately.

- The operations required must be carried out by the manufacturer's customer service department or a customer service organisation authorised by the manufacturer.

## 11 Disposal

Batteries marked with the recycling symbol and the sign showing a crossed-out rubbish bin should not be disposed of with ordinary household waste.

Buy-back terms and type of recycling are to be agreed with the manufacturer as described in § 8 of the battery legislation.

