

MODEL  
**210/220**—————  
***OPERATOR'S MANUAL***



A **PACCAR** COMPANY

# Table of contents

---

Why this handbook is so important! . . . . .	9
<b>Warnings and Safety Regulations . . . . .</b>	<b>11</b>
Safety alerts . . . . .	12
Warnings and safety regulations . . . . .	14
Emergency equipment . . . . .	16
Technical items of special importance . . . . .	21
Jump starting vehicles . . . . .	25
<b>Cab, Instruments and Controls . . . . .</b>	<b>31</b>
Entering and leaving the vehicle . . . . .	32
Doors . . . . .	33
Electrically operated windows . . . . .	34
Heated Mirrors . . . . .	34
Mirrors . . . . .	35
Electrical mirror adjustment . . . . .	35
Windshield wiper blades . . . . .	35
Roof console . . . . .	36
Sun visors . . . . .	36
Stepwell lighting . . . . .	36
Interior lighting . . . . .	37

# Table of contents

---

Dashboard . . . . .	38
Instrument panel . . . . .	40
Warning indicators . . . . .	45
Control panel . . . . .	51
Control panel of heating/ventilation system. . . . .	56
Air conditioning switch. . . . .	57
Fan speed selector switch . . . . .	60
Temperature adjustment. . . . .	60
Air distribution selector switch . . . . .	61
Center console. . . . .	62
Left-hand steering column switch. . . . .	65
Right-hand steering column switch. . . . .	66
Steering wheel switches . . . . .	67
Adjustable steering column . . . . .	68
<b>Seats . . . . .</b>	<b>69</b>
Important points . . . . .	70
Seat belts . . . . .	72

# Table of contents

---

<b>Master Display</b> .....	<b>77</b>
General .....	78
Layout of master display .....	79
Start-up phase .....	80
Menu selector switch .....	82
Menu overview .....	84
Faults .....	86
Warning symbols .....	87
<b>Inspections and Maintenance</b> .....	<b>91</b>
Overview of daily checks .....	92
Opening the front panel .....	92
Engine oil level .....	93
Topping up coolant .....	94
Special coolant fill instructions .....	96
Windshield washer reservoir fluid level .....	97
Air filter indicator .....	97
Wheels and tires .....	98
Lighting and instruments .....	98
Driver's seat and mirrors .....	99

# Table of contents

---

Overview of weekly checks .....	99
Power steering fluid level .....	100
Brake system air drier .....	100
Draining the water separator .....	101
Batteries .....	102
General maintenance .....	103
Cab maintenance .....	103
Cleaning .....	104
Preventative maintenance before the winter season .....	107
Diesel fuel .....	107
Cab heater .....	108
Windshield washer reservoir .....	108
Maintenance after the winter season .....	108
Cooling system .....	108
<b>PDC &amp; Voltage Converter .....</b>	<b>109</b>
Power distribution center .....	110
<b>Driving .....</b>	<b>113</b>
General .....	114
Steering lock/contact/starter switch .....	115
Glow system .....	115

# Table of contents

---

Starting procedure . . . . .	116
Engine speed control . . . . .	117
Cruise control . . . . .	119
Vehicle speed limitation for special applications . . . . .	122
Driving style . . . . .	122
Steering . . . . .	123
ABS brakes . . . . .	123
Parking brake and service brake . . . . .	125
Engine brake . . . . .	126
Stopping . . . . .	127
<b>Automatic Gearbox . . . . .</b>	<b>129</b>
Allison 2100 series . . . . .	130
<b>Emergency Repairs . . . . .</b>	<b>133</b>
Tilting the cab . . . . .	134
Replacing the poly-V belt . . . . .	137
Replacing the fuel fine filter . . . . .	138
Draining the water separator . . . . .	139
Releasing the parking brake . . . . .	140
Jacking up the front axle . . . . .	140

# Table of contents

---

Jacking up the rear axle . . . . .	141
Changing the wheel. . . . .	142
Tire inflating connection. . . . .	146
Towing . . . . .	147
Replacing bulbs. . . . .	149
Fuses and relays . . . . .	152
<b>Technical Data and Identification . . . . .</b>	<b>157</b>
Engine. . . . .	158
Electrical system . . . . .	159
Wheels . . . . .	160
tire pressure table (Metric) . . . . .	161
Lubricant-, engine coolant- and fuel specifications. . . . .	162
Engine oil . . . . .	164
Coolants . . . . .	165
Steering gear . . . . .	167
Cab tilting mechanism . . . . .	167
Chassis number. . . . .	168
Engine number . . . . .	168
Paint identification plate . . . . .	169
Vehicle identification label . . . . .	169

## Table of contents

---

<b>Consumer Information</b> .....	<b>171</b>
Federal safety standard certification label .....	172
<b>Alphabetical index</b> .....	<b>177</b>



# Table of contents

---

## WHY THIS HANDBOOK IS SO IMPORTANT!

This handbook contains the information which you, the driver, will need for optimum efficiency, safety and comfort when operating this vehicle. Besides giving instructions about operation and use, it also pays attention to maintenance and minor repairs which you may be able to carry out yourself.



### NOTE

This handbook is based on the chassis with its fittings as it originally left the factory.

Depending upon the required body and equipment, the bodybuilder may have made fundamental changes to various parts or systems, such as the instrument panel, the lighting or the electric wiring.

The vehicles covered by this handbook consist of various types and models. Certain descriptions or illustrations in this handbook may not correspond entirely to the situation on your own vehicle. However, this has practically no influence on its operation or maintenance.

Every new vehicle is designed to conform to all Federal Motor Vehicle Safety Standards applicable at the time of manufacture. Even with these safety features, continued safe and reliable operation depends greatly upon regular vehicle maintenance. Follow the maintenance recommendations found in Preventive Maintenance on [page 107](#). This will help preserve your investment

---

### **Important**

Make sure this handbook is in the vehicle at all times.

Read it carefully **before making your first journey**, especially the **"Warnings and safety precautions"**, **"Cab, instruments and controls"**, **"Inspections"** and **"Driving"** sections.

## Warnings and Safety Regulations

# Warnings and Safety Regulations

## SAFETY ALERTS

Please read and follow all of the safety alerts contained in this manual. They are there for your protection and information. These alerts can help you avoid injury to yourself, your passengers, and it can also help prevent costly damage to the vehicle. Safety alerts are highlighted by safety alert symbols and signal words such as "WARNING", "CAUTION", or "NOTE". Please do not ignore any of these alerts.



## Warnings

The safety message following this symbol and signal word provides a warning against operating procedures which could cause injury or even death. They could also cause equipment or property damage. The alert will identify the hazard, how to avoid it, and the probable consequence of not avoiding the hazard.

Example:



### **WARNING**

**Do not carry additional fuel containers in your vehicle. Fuel containers, either full or empty, may leak, explode, and cause or feed a fire. Do not carry extra fuel containers. Even empty ones are dangerous. Failure to comply may result in death or personal injury.**

# Warnings and Safety Regulations



## Cautions

The safety alert following this symbol and signal word provides a caution against operating procedures which could cause equipment or property damage. The alert will identify the hazard, how to avoid it, and the probable consequence of not avoiding the hazard.

Example:



### CAUTION

**Continuing to operate your vehicle with insufficient oil pressure will cause serious engine damage. Failure to comply may result in equipment or property damage**

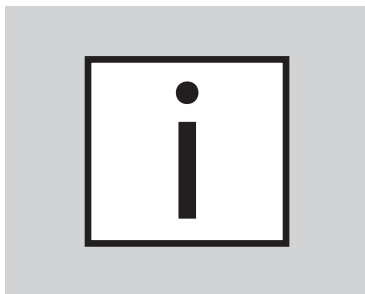

## Notes

The alert following this symbol and signal word provides important information that is not safety related but should be followed. The alert will highlight things that may not be obvious and is useful to your efficient operation of the vehicle.

Example:



### NOTE

Pumping the accelerator will not assist in starting the engine.

# Warnings and Safety Regulations

---

## WARNINGS AND SAFETY REGULATIONS



### **WARNING**

**To prevent damage to the vehicle and in order not to jeopardize your health and/or safety, or that of other people, the following warning and safety regulations must be strictly observed.**

First read the instructions and warnings on the labels and stickers on the various components and comply with them!

They have been put there for your health and safety, so do not ignore them!

### **Modifications to the vehicle**

Modifying your vehicle can make it unsafe. Some modifications can affect your vehicle's electrical system, stability, or other important functions. Before modifying your vehicle, check with your dealer to make sure it can be done safely. Improper modifications can cause death or personal injury.

# Warnings and Safety Regulations

## Environmental Protection



### **CALIFORNIA PROPOSITION 65 WARNING**

- **Diesel engine exhaust and some of its constituents are known to the State of California to cause cancer, birth defects, and other reproductive harm.**
- **Other chemicals in this vehicle are also known to the State of California to cause cancer, birth defects or other reproductive harm.**
- **Battery posts, terminals, and related accessories contain lead and lead compounds, chemicals known to the State of California to cause cancer and reproductive harm. Wash hands after handling.**

## Components

Do not work on or near the fan with the engine running. Anyone near the engine fan when it turns on could be seriously injured. If it is set at **MANUAL**, the fan will turn on any time the ignition key switch is turned to the **ON** position. In **AUTO**, it could engage suddenly without warning. Before turning on the ignition or switching from **AUTO** to **MANUAL**, be sure no one is near the fan.



# Warnings and Safety Regulations

## Cooling system filler cap



### **WARNING**

**Do not remove the radiator fill cap while the engine is hot. Scalding steam and fluid under pressure may escape. You could be badly burned. Failure to comply may result in death or personal injury.**

## **EMERGENCY EQUIPMENT**

It is good practice to carry an emergency equipment kit in your vehicle. One day, if you have a roadside emergency, you will be glad the following items are with you:

- Window scraper
  - Snow brush
  - Container or bag of sand or salt
  - Emergency light
  - Warning triangles
  - Small shovel
  - First aid kit
  - Fire extinguisher
  - Vehicle recovery hitches
- (see Towing on [page 147](#) for details).

# Warnings and Safety Regulations

## Fire extinguisher

Ensure that you are always in possession of a fire extinguisher. It should be well secured under the seat, within the driver's reach and easily accessible, also for rescue workers and others providing assistance. Have the fire extinguisher checked for operational readiness each year. If it has been used, have it refilled at the earliest opportunity.

## In the event of fire:

In the event of a fire, certain plastic seals can produce gases which together with water form a corrosive acid. Do not touch any fire extinguisher fluid on the vehicle without protective gloves.

## Cab



### **WARNING**

**Do not carry loose objects in your cab, it can be dangerous. In a sudden stop, or even going over a bump in the road, they could fly through the air and strike you or a passenger. You could be injured or even killed. Secure all loose objects in the cab before moving the vehicle. Carry any heavy objects such as luggage in the exterior storage compartment and close it securely.**

## First aid kit

Ensure that you are always in possession of a first aid kit and replace first aid items as soon as possible after use to have the kit always ready.

# Warnings and Safety Regulations

## Tire chains

If you need tire chains, install them on both sides of each driving axle.



### CAUTION

**Chains on the tires of only one tandem axle can damage the driveline U-joints and the interaxle differential. Your repairs could be costly and time-consuming.**

## Approaching Your Vehicle

- Check the overall appearance and condition. Are windows, mirrors, and lights clean and unobstructed?
- Check beneath the vehicle. Are there signs of fuel, oil, or water leaks?
- Check for damaged, loose, or missing parts. Are there parts showing signs of excessive wear or lack of lubrication? Have a qualified mechanic examine any questionable items and repair them without delay.
- Check your load. Is it secured properly?

## Oils and lubricants

Various kinds of oil and other lubricants used on the vehicle may constitute a health hazard if they come into contact with the skin. This also applies to engine coolant, windshield washer fluid, refrigerant in air conditioning systems, battery acid and diesel fuel. So avoid direct contact as much as possible.

The engine and the surrounding area must be free of inflammable materials to avoid the risk of fire.

Exercise caution when changing hot oil; it can cause serious bodily injury.

# Warnings and Safety Regulations



## **WARNING**

**Air conditioning refrigerant can be hazardous to your health. Do not expose yourself to leaking refrigerant for prolonged periods near excessive heat, open flames, or without proper ventilation. Failure to do so may result in death or personal injury.**

## **Maintenance activities**

When carrying out maintenance work under the cab, make sure the cab is fully tilted and locked to prevent it from falling back accidentally.

Following a collision, only tilt the cab in an emergency situation. The tilting mechanism may be damaged. (The end stop may no longer be on the lifting cylinder.)



## **WARNING**

**Always support the vehicle with appropriate safety stands if it is necessary to work underneath the vehicle. A jack is not adequate for this purpose.**

## **Maintenance of air conditioning system**



## **WARNING**

**Excessive heat may cause the pressurized components of the air conditioning system to explode. Never weld, solder, steam clean, or use a blow torch near any part of the air conditioning system. Failure to comply may result in personal injury, death, equipment or property damage.**

# Warnings and Safety Regulations



## **WARNING**

**Air conditioning refrigerant can be hazardous to your health. Do not expose yourself to leaking refrigerant for prolonged periods near excessive heat, open flames, or without proper ventilation. Failure to do so may result in death or personal injury or death.**



## **WARNING**

**The air conditioning system is under pressure. If not handled properly during servicing, it could explode. Any servicing that requires depressurizing and recharging the air conditioning system must be conducted by a qualified technician with the right facilities to do the job. Failure to comply may result in personal injury, death, equipment or property damage.**

## **Environment**

Pollution constitutes a serious threat to the environment. To keep pollution to a minimum, the following rules should be observed:

- Do not dump used oil, fuel, lubricants, hydraulic fluid or coolants in drains, sewers, in landfills or on the ground. This is illegal. These fluids should be returned to the designated authority or appropriate chemical waste collection company for recycling or destruction. All used fluids should be stored separately.
- Make sure that the vehicle is serviced regularly according to the instructions and recommendations. A properly serviced vehicle helps optimize fuel economy and reduce the level of harmful constituents in the exhaust gases.

# Warnings and Safety Regulations

## TECHNICAL ITEMS OF SPECIAL IMPORTANCE

To prevent damage to the vehicle, the following instructions must be strictly observed.

### Running-in

During the running-in period it is best not to subject the new vehicle to excessive loads. This also applies when an overhauled engine, transmission or differential has been installed. Therefore, for the first 1,500 km (932 miles): drive carefully and avoid accelerating sharply.

**The following technical items of special importance apply to both the running-in period and to the period thereafter.**

**After a cold start** continue to drive in a low gear and at a moderate engine speed until the engine coolant temperature is out of the blue zone.

While driving, check **the instrument panel** regularly and take appropriate action if you notice anything unusual, such as strange engine or transmission noises, smoke, or poor performance. Do not let the engine **idle for longer than necessary**. This is harmful to the engine and also causes unnecessary pollution of the environment.

Be aware that **engine stalling** while driving will lead to power steering failure. Consequently, the vehicle will be more difficult to steer.

The engine cooling system is thermostatically controlled.

**Removing the thermostat** when the coolant temperature is (too) high serves no useful purpose and is strongly advised against, since this will only cause the engine temperature to rise to an even higher level.

The **turbocharger** is a precision component. You should therefore immediately report any abnormal noise that seems to be coming from this component.

# Warnings and Safety Regulations

## Air leakage

If the pressure in the air reservoirs drops rapidly with the engine switched off, this indicates a leak. Since this affects the safety of the brake system, the leak must be traced and repaired as quickly as possible.

## System voltage

The cab system of this vehicle are on 24-Volt while other areas remain 12-Volt. When replacing or fitting electrical or electronic components, always verify that they are suitable for this system voltage.

## Batteries



### **WARNING**

**Never disconnect the battery leads while the engine is running!**

Always disconnect the battery negative (ground) lead before carrying out repairs or service on the electrical system.



### **WARNING**

**Before attempting any work on the batteries or electrical system, remove all jewelry. If metal jewelry or other metal comes in contact with electrical circuits, a short circuit may occur causing you to be injured, as well as causing electrical system failure and damage.**

# Warnings and Safety Regulations

## Charging



### **WARNING**

Thaw out frozen batteries before charging them. Remove all the filler caps before charging.



### **WARNING**

Charger cables must be connected positive to positive (+ to +) and negative to negative (- to -). If connected improperly, batteries could explode. Failure to comply may result in personal injury, death, equipment or property damage.



### **WARNING**

Always make sure the battery charger is OFF before connecting or disconnecting the cable clamps. To reduce the danger of explosions and resulting death or personal injury, do not connect or disconnect charger cables while the charger is operating.

## Charging Reminders

- Use protective eyewear.
- Keep all batteries away from children.
- Never reverse battery poles.
- Never attempt to place the vehicle in motion, or run the engine with batteries disconnected.
- Keep the battery clean and dry.
- Look for any signs of damage.



# Warnings and Safety Regulations

- Battery terminals should not be coated with improper grease. Use petroleum jelly or commercially available, noncorrosive, nonconductive terminal coatings.
- Never use a fast charger as a booster to start the engine. This can seriously damage sensitive electronic components such as relays, radio, etc., as well as the battery charger. Fast charging a battery is dangerous and should only be attempted by a competent mechanic with the proper equipment.

## **Battery capacity**

Using electrical components, such as the cab heater or refrigerator when the engine is not running, power will be drawn from the batteries.

Approximately half the battery capacity is required to start the engine.

If this is the case over a protracted period, particularly during low temperatures, the result may be that the electrical components have used so much power that there is not enough to start the engine.

If the high current draw electrical components, such as the cab heater, refrigerator, coffee percolator, microwave oven or tail-lift are used, it is recommended that you obtain batteries of an adequate higher capacity in consultation with your dealer.

## **Welding**

For welding on the vehicle and/or superstructure, see the "Bodybuilders Manual". Not following the welding instructions can cause damage to the electronic components.

# Warnings and Safety Regulations

## JUMP STARTING VEHICLES

### Introduction

Jump starting a vehicle is not a recommended practice due to the various battery installations and electrical options. However, if your battery is discharged (dead), you may be able to start it by using energy from a good battery in another vehicle. This is termed jump starting. Be sure to follow the precautions and instructions below.



#### **WARNING**

**Batteries contain acid that can burn and gasses that can explode. Ignoring safety procedures may result in death, personal injury, equipment or property damage.**



#### **WARNING**

**Never jump start a battery near fire, flames, or electrical sparks. Batteries generate explosive gases that could explode. Keep sparks, flame, and lighted cigarettes away from batteries. Failure to comply may result in death, personal injury, equipment or property damage.**



#### **WARNING**

**Never remove or tamper with battery caps. Ignoring this could allow battery acid to come in contact with the eyes, skin, fabrics, or painted surfaces. Failure to comply may result in death, personal injury, equipment or property damage. Be careful that metal tools (or any metal in contact with the positive terminal) do not contact the positive battery terminal and any other metal on the vehicle at the same time. Remove metal jewelry and avoid leaning over the battery.**

# Warnings and Safety Regulations

## To Jump Start Your Vehicle



### **WARNING**

When jump starting using a booster battery, it is best to jump start with an equivalently powered vehicle. Verify that the booster battery has the same volt and CCA specifications as the dead battery before attempting to jump start. Failure to comply may cause an explosion resulting in death, personal injury, equipment or property damage.



### **CAUTION**

Applying a higher voltage booster battery will cause expensive damage to sensitive electronic components such as relays, and the radio. Failure to comply may result in equipment damage. Improper hook-up of jumper cables or not following these procedures can damage the alternator or cause serious damage to both vehicles.



### **WARNING**

Heed all warnings and instructions of the jumper cable manufacturer. Failure to comply may result in personal injury, death and equipment or property damage.

# Warnings and Safety Regulations

---

## Preparing the vehicles:

- 1 Remove any jewelry that may come in contact with the battery terminals.
- 2 Select a jumper cable that is long enough to attach to both vehicles in a way that ensures neither vehicle touches each other.
- 3 Position the two vehicles together, but do not allow them to touch.
- 4 Turn OFF all lights, heater, radio, and any other accessory on both vehicles.
- 5 Set the parking brakes: pull out the Yellow button located on the dash.
- 6 Shift the transmission into park position or neutral for manual transmissions. (See "Shifting Gears" on [page 130](#) and "PARKING BRAKE AND SERVICE BRAKE" on [page 125](#), for transmission shifting and parking brake information.)
- 7 If either vehicle is equipped with battery disconnects ensure they are in the "OFF" position prior to connecting the two vehicles.

# Warnings and Safety Regulations

---

## **Connect the batteries:**

- 1 Attach one end of a jumper cable to the positive (+) terminal of the discharged (dead) battery. This will have a large red + or P on the battery case, post, or clamp.
- 2 Attach the other end of the same cable to the positive (+) terminal of the good (booster) battery.
- 3 Attach the remaining jumper cable FIRST to the negative (-) terminal (black or N) of the good battery.
- 4 Attach the other end of the negative cable to a bare metal part not bolted to the engine block.

**IMPORTANT: Always connect positive (+) to positive (+) and negative (-) to negative (-).**

- 5 If either vehicle is equipped with battery disconnects, ensure that they are in the "ON" position.
- 6 Start the vehicle that has the good battery first. Let it run for 5 minutes.
- 7 Start the vehicle that has the discharged (dead) battery. If the engine fails to start, do not continue to crank the starter and contact the nearest authorized dealer

# Warnings and Safety Regulations

## Remove jumper cables:



### **WARNING**

When disconnecting jumper cables, make sure they do not get caught in any moving parts in the engine compartment. Failure to comply may result in death, personal injury, equipment or property damage.

Reverse the above procedure exactly when removing the jumper cables. With the engine running, disconnect jumper cables from both vehicles in the exact reverse order (Steps 4-1), making sure to first remove the negative cable from the vehicle with the discharged battery.



### **NOTE**

Review the warranty policy before performing any maintenance procedures. An extended warranty may be voided if unauthorized maintenance is performed during this period.



### **CAUTION**

Do not modify or improperly repair the vehicles electrical system or power distribution center. All electrical repairs should be performed by an authorized dealer. Improper repair or modifications will void your warranty and/or cause serious damage to your vehicle.

# Warnings and Safety Regulations

## Disconnect Switch

This vehicle has a disconnect switch. Ensure that your vehicle ignition has been turned off for at least 40 seconds before switching the disconnect switch to the OFF position



### NOTE

Wait 2 minutes after key-off before disconnecting battery power. Disconnecting battery power sooner can result in damage to vehicle DEF.

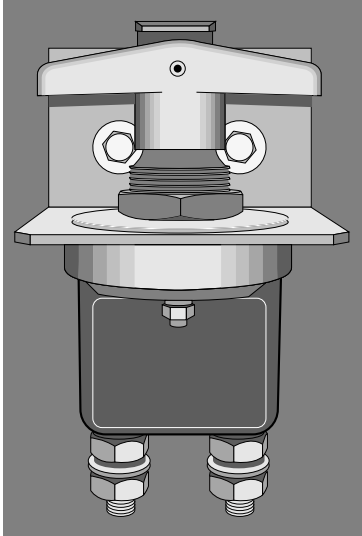

D0 02 014

## CAUTION

**Wait 2 minutes after  
key-off before  
disconnecting battery power.  
Disconnecting battery power  
sooner can result in damage  
to vehicle DEF system.**

P53-6080-000

## Cab, Instruments and Controls



# Cab, Instruments and Controls



D0 00 632

## ENTERING AND LEAVING THE VEHICLE



### WARNING

Always reinstall steps before entering the cab or accessing the deck plate. Without steps you could slip and fall. Be careful whenever you get into or out of your vehicle's cab. Always maintain at least three points of contact with your hands on the grab handles and your feet on the steps. Failure to comply may result in personal injury or death.



### WARNING

Jumping out of the cab or getting into the cab without proper caution is dangerous. You could slip and fall, which could lead to personal injury or death. Keep steps clean. Clean any fuel, oil, or grease off of the steps before entering the cab. Use the steps and grab handles provided, and always keep at least three points of contact between your hands and feet and the truck. Look where you are going.

The picture shows the best way to enter and exit a Cab-Over Engine Cab.

# Cab, Instruments and Controls

## DOORS



### WARNING

To help lessen the chance and/or severity of death or personal injury in case of an accident, always lock the doors while driving. Along with using the lap shoulder belts properly, locking the doors helps prevent doors from inadvertently opening and occupants from being ejected from the vehicle.

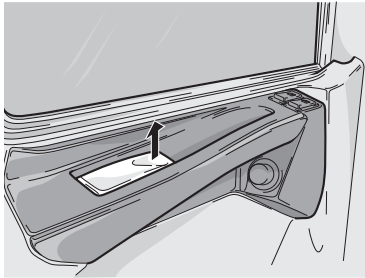

DO 00 604

### Opening the door

Pull the handle to open the door from the inside.

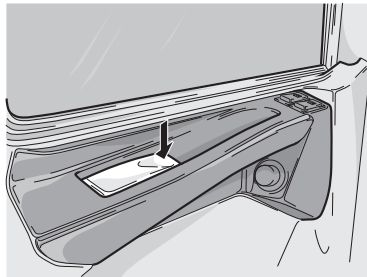

DO 00 611

### Locking the door from the inside

Press the door handle downwards.

### Standard version

Both doors can be locked and unlocked from the outside using the key.

# Cab, Instruments and Controls

## Central door locking

### Unlocking

To open the doors of a vehicle with central door locking, use the same procedure described before.

The door on the co-driver's side can be locked/unlocked using the switch on the center console.

### Locking

- Both doors are locked when one of the doors is closed with the key.
- Avoid locking yourself out!



D0 00 585-1

## ELECTRICALLY OPERATED WINDOWS

The switches only work when the ignition is switched on.

The driver's and co-driver's windows can be opened and closed with the switches in the driver's door. The switch in the co-driver's door can only open and close the co-driver's window.

## HEATED MIRRORS

With the switch for mirror/windscreen heating, the exterior mirrors (excluding curb mirror) and the windscreen heating, if fitted, can be heated. When you press the switch again, the mirror heating is switched off the windscreen heating remains active for about 12 minutes. If you press the switch again within 12 minutes, the windscreen heating is switched off and the mirror heating is switched on again. Operate the switch once more to switch everything off.

# Cab, Instruments and Controls

## MIRRORS

The mirror housing and mounting bracket is fixed to the cab. Only the face of the mirror is adjustable within the mirror housing.

The mirror bracket can be folded back against the cab and will return to its original position once the bracket is swung out again.

All models have Flat glass mirror.

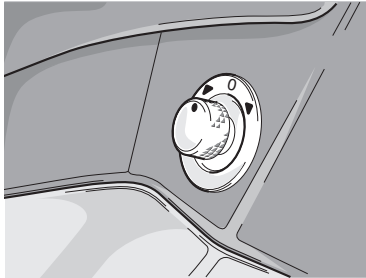

D0 00 612

## ELECTRICAL MIRROR ADJUSTMENT

The electric mirrors can be adjusted by means of the switch in the driver's door.

Select the right or left mirror by turning the button either to the right or left position.

Move the switch forwards, backwards, left or right, to adjust the mirror.

## WINDSHIELD WIPER BLADES

To prevent damage to the wiper blades during operation in winter conditions, always check that the blades are not frozen to the windshield. This can be prevented by placing something between wiper blades and windshield. Switch off the windshield wipers before turning off the ignition.



### WARNING

**Clean blades regularly with a damp cloth to remove road film and wax build-up. Do not drive with worn or dirty wiper blades. They can reduce visibility, making driving hazardous which may lead to an injury accident resulting in personal injury or death.**

# Cab, Instruments and Controls

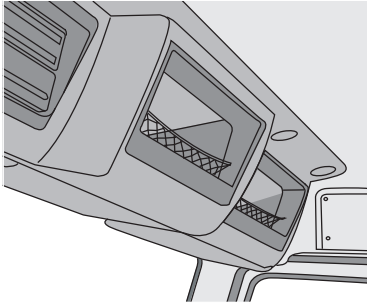

D0 02 001

## ROOF CONSOLE



### WARNING

Overhead compartments are not intended for personnel use or for items exceeding their designed weight limits. Exceeding the weight limits may cause the shelf to collapse and or items may fall out in a sudden stop which may lead to personal injury or death.

## SUN VISORS

As a protection against sun glare, the sun visors can be folded down. The sun visor on the driver's side can also serve as a side window shade.

## STEPWELL LIGHTING

In both doors, a lamp is fitted at the bottom to light the stepwell. This will light up as soon as the door is opened.

# Cab, Instruments and Controls

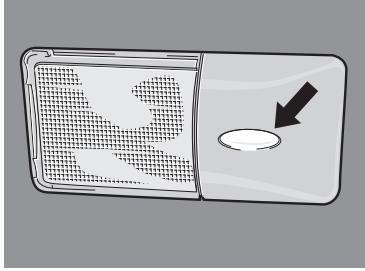

D0 01 197

## INTERIOR LIGHTING

The interior lighting operates independently of the position of the contact key. The interior light comes on when the door is opened. When the doors are open for more than 15 minutes, the interior lamps will be extinguished. The lamp stays lit by operating the switch on the lamp.

# Cab, Instruments and Controls

## DASHBOARD

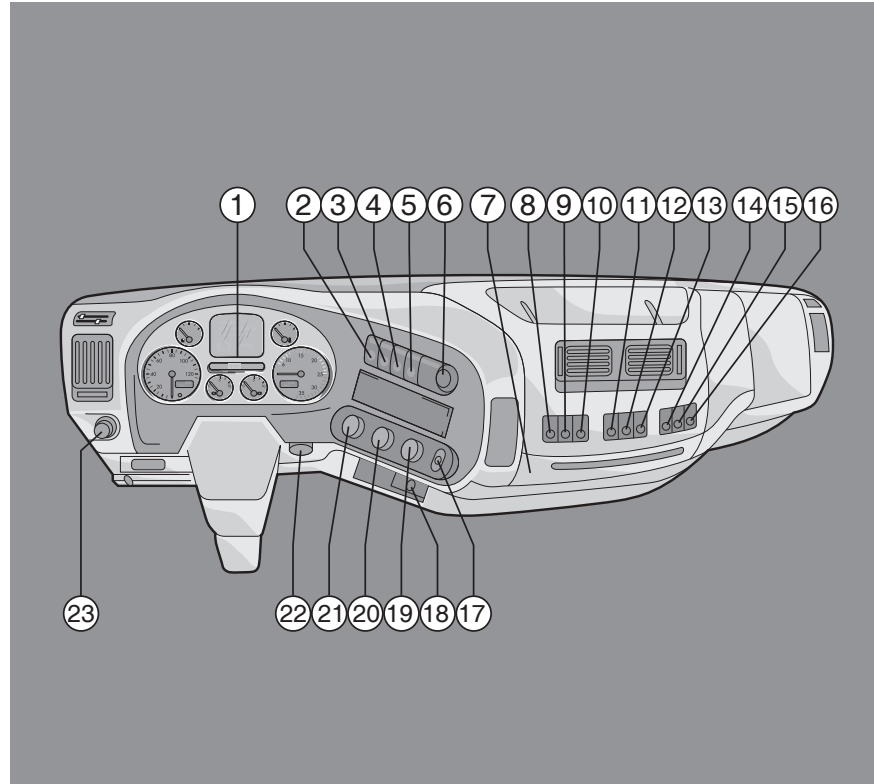

D001183

# Cab, Instruments and Controls

---

- 1 Instrument panel
- 2 Dimmer, dashboard lighting
- 3 (unused)
- 4 (unused)
- 5 Front fog lamps
- 6 Menu selection switch
- 7 Ashtray with 12V auxiliary socket
- 8 Hazard warning lights
- 9 (unused)
- 10 (unused)
- 11 (unused)
- 12 (unused)
- 13 (unused)
- 14 (unused)
- 15 PTO operation
- 16 (unused)
- 17 Air conditioning
- 18 12V connection
- 19 Heater, fan speed selector switch in fresh air position or re-circulation position
- 20 Heater, temperature control
- 21 Heater, air distribution selector switch
- 22 (unused)
- 23 Lighting switch



# Cab, Instruments and Controls

## INSTRUMENT PANEL

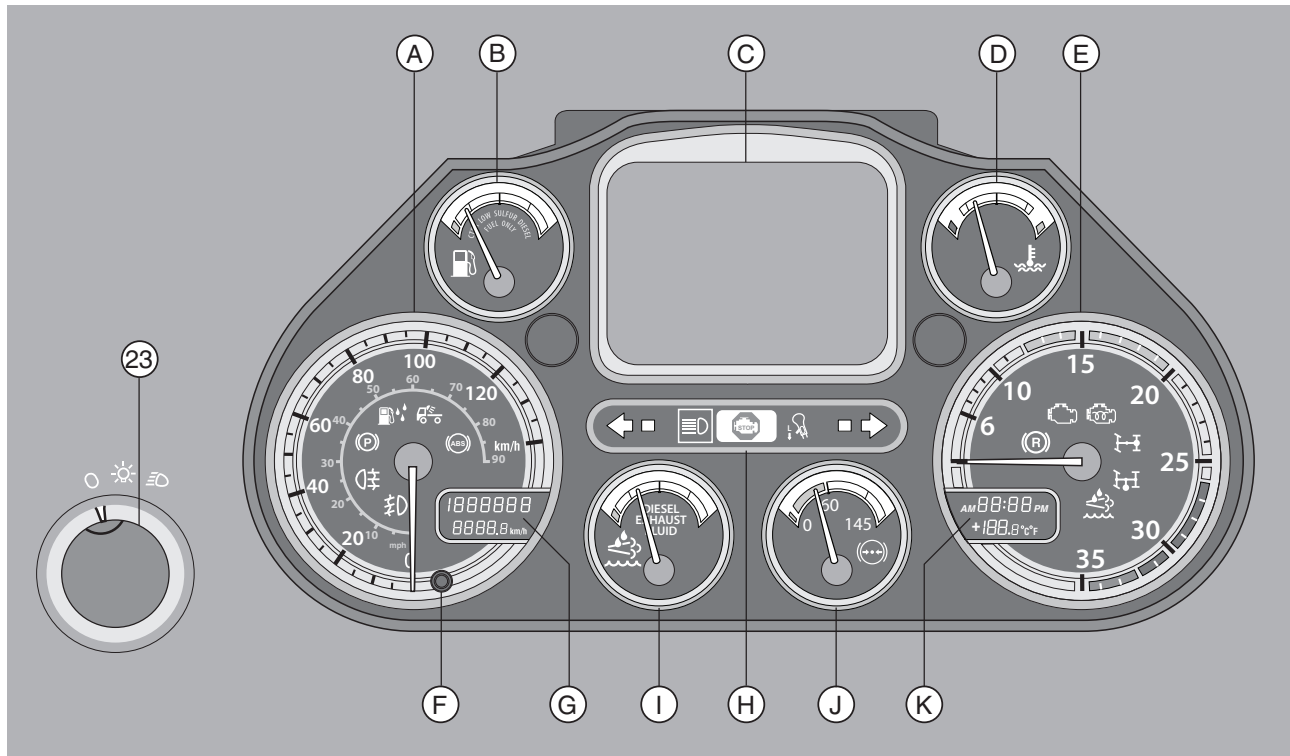

D001198-1

# Cab, Instruments and Controls

---

- A Speedometer
- B Fuel gauge
- C Master display
- D Coolant temperature gauge
- E Tachometer
- F Reset button, trip odometer
- G Odometer and trip meter
- H Warning indicators
- I Diesel exhaust fluid
- J Circuit 1
- K Outside temperature and clock

# Cab, Instruments and Controls

**MPH**  
**km/h**

## **A. SPEEDOMETER**

This vehicle's speedometer is equipped with double scale divisions. Either major divisions in mph and minor divisions in kph or major divisions in kph and minor divisions in mph.



## **B. FUEL GAUGE**

The fuel gauge only operates when the contact is on.

Factor in the delay on the gauge when the contact is turned on.

## **C. MASTER DISPLAY**

See "MASTER DISPLAY".



## **D. COOLANT TEMPERATURE GAUGE**

The engine should not be operated under full load if the temperature is in the blue field.

The engine is at operating temperature when the temperature gauge is vertical, or slightly further.

If the coolant temperature suddenly rises and/or the pointer is in the red field, the following points should be checked:

- coolant level (caution – danger of scalding; see "Topping up coolant" in "INSPECTIONS AND MAINTENANCE");
- poly V-belt and water hoses;
- fan clutch.



## **E. REV COUNTER**

Green area: economical

White: less economical

Blue area: only permitted when driving downhill and for optimal use of the engine brake

Red area: not permitted

## **F. TRIP METER RESET BUTTON**

The trip meter is set to zero with the reset button.

## **G. ODOMETER AND TRIP METER**

The total distance is displayed in "km" or "mils" in the top section of the display.

## **H. WARNING INDICATORS**

See section concerned.

## **I. DIESEL EXHAUST FLUID GAUGE**

The Diesel Emission Fluid gauge indicates the total (approximate) amount of DEF in the tank. In addition to indicating empty and full, the gauge also indicates the DEF level in graduated increments. When the DEF level in the tank reaches 10% full, a red warning light in the gauge illuminates. When the DEF level in the tank reaches 5%, Refer to your PACCAR Engine After-Treatment Control Operator's Manual for more information.

# Cab, Instruments and Controls

## J. AIR PRESSURE GAUGE, CIRCUITS 1

The air pressure gauge indicates the air pressure in the reservoirs of one of the service brake circuits. If the pressure in one of the circuits drops below 65 psi (448.15 kPa), an audible alarm is generated and the warning symbol "Air system pressure too low" will illuminate in the master display. When the pressure is higher than 66.5 psi (458.5 kPa), the brakes can be released with the parking brake lever. The audible alarm and warning symbol are only generated when the ignition key is on. The gauge also operates when the ignition key is off.

The vehicle must not be driven when the audible alarm sounds or when the pressure in one of the circuits is lower than approx. 65 psi (448.15 kPa).



### NOTE

The air pressure warning will be activated when primary or secondary air systems drops below 65 psi.

## K. OUTSIDE TEMPERATURE AND CLOCK

The display is activated when the contact is on.

The clock is shown in the top section of the display.

The outside temperature is displayed in the bottom section in degrees C or degrees F.

# Cab, Instruments and Controls

## WARNING INDICATORS

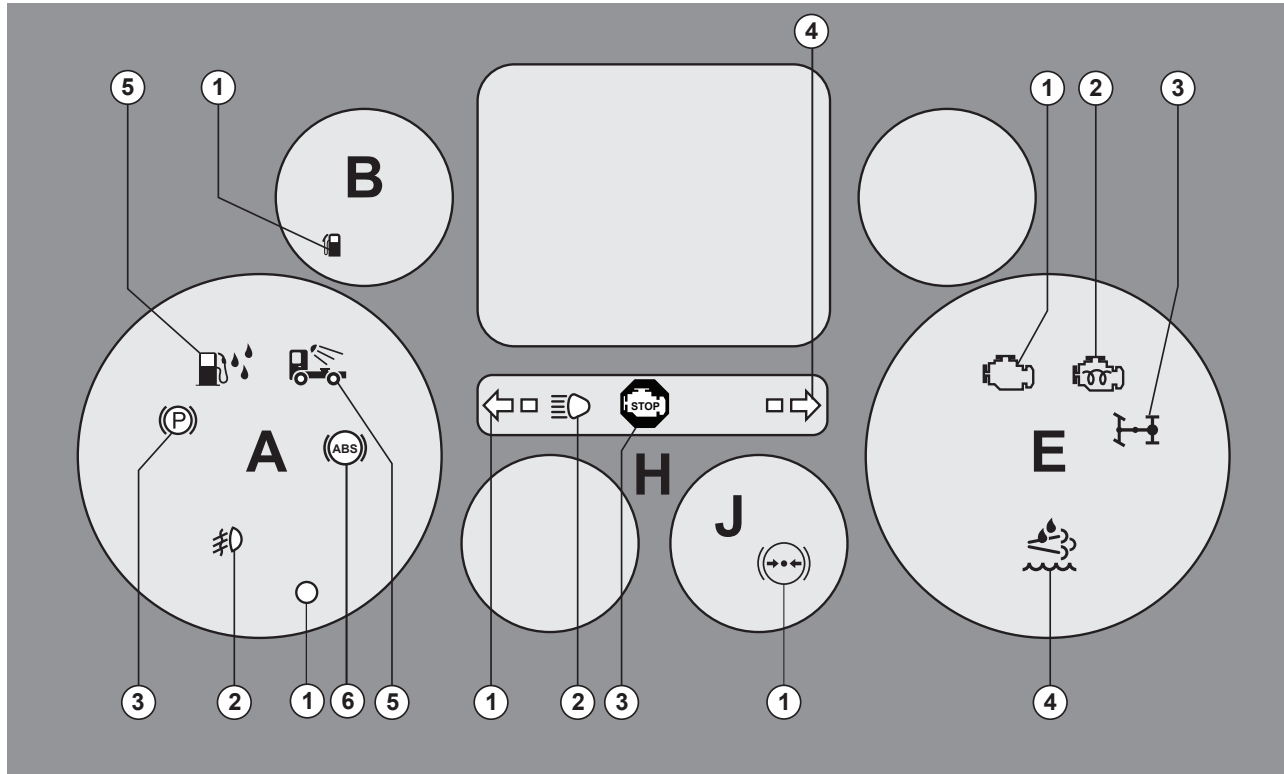

D0 00 786-1

# Cab, Instruments and Controls

---

A1	Tachograph
A2	Front fog lights
A3	Parking brake
A4	Water in fuel
A5	Work lamp/loadspace lighting
A6	ABS symbol
B1	Fuel level low
E1	Engine warning
E2	Pre-Heating
E3	PTO engaged
E4	DEF level
H1	Left direction indicator, truck or tractor
H2	Main beam
H3	Central "STOP" warning indicator
H4	Right direction indicator, truck or tractor
J	Brake air

# Cab, Instruments and Controls

## A1. Tachograph fault

See messages in Tachograph operation manual.



## A2. Front fog lights

This warning indicator lights up if the front fog lights are switched on.

## A3. (unused)



## A4. Parking brake

This warning indicator lights up if the parking brake is applied, or when the pressure in the air system is too low to enable the parking brake to be released.



## A5. Water In Fuel



## A6. Work lamp/loadspace lighting

The warning indicator lights up when the work lamp/loadspace lighting is switched on.



# Cab, Instruments and Controls



## **A7. ABS**

The yellow warning symbol "ABS truck fault" is activated if a fault in the ABS system of the truck or tractor.



## **B1. Fuel level low**

This warning indicator lights up when the reserve fuel level is reached. The fuel reserve then is about 10% of the tank capacity. Refuel as soon as possible.

## **E1. (unused)**

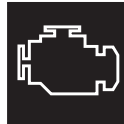

## **E2. Engine warning**

This warning will be activated when the system requires attention, general danger spot or failure of emission system.

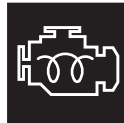

## **E3. Pre-Heating**

If the ignition key is on, the engine ECU automatically determines the necessary preglowing and afterglowing times.

The necessary preglowing and afterglowing times depend on the temperature that is measured by the engine management system.

If the preglowing or afterglowing function is activated by the engine ECU, this warning indicator lights up.

# Cab, Instruments and Controls

## E4. (unused)



## E5. PTO engaged

This warning indicator lights up when the PTO is switched on.



## E6. DEF level

This warning will be activated if DEF level is lower than 10%.

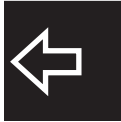

## H1. Left direction indicator, truck or tractor

This warning indicator flashes together with the direction indicators on the truck or tractor.

## H2. (unused)



## H3. Main beam

This warning indicator lights up if the main beam is switched on or the headlight flash is operated.

# Cab, Instruments and Controls



## H4. Central "STOP" warning indicator

The central "STOP" warning lights up when there is a serious fault in one of the vehicle functions. The master display shows which vehicle function has triggered the warning.



### **WARNING**

**This should be considered an emergency. You should stop the vehicle as safely as possible and turn OFF the ignition. The vehicle must be serviced and the problem corrected before driving again. Failure to do so may cause severe engine damage or cause an accident involving personal injury or death.**

H5. (unused)

H6. (unused)

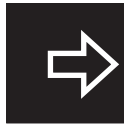

## H7. Right direction indicator, truck or tractor

This warning indicator flashes together with the direction indicators on the truck or tractor.



## J. Brake air

This warning is printed on the gauge. It will not be activated, since it lights up with the gauge light.

# Cab, Instruments and Controls

## CONTROL PANEL

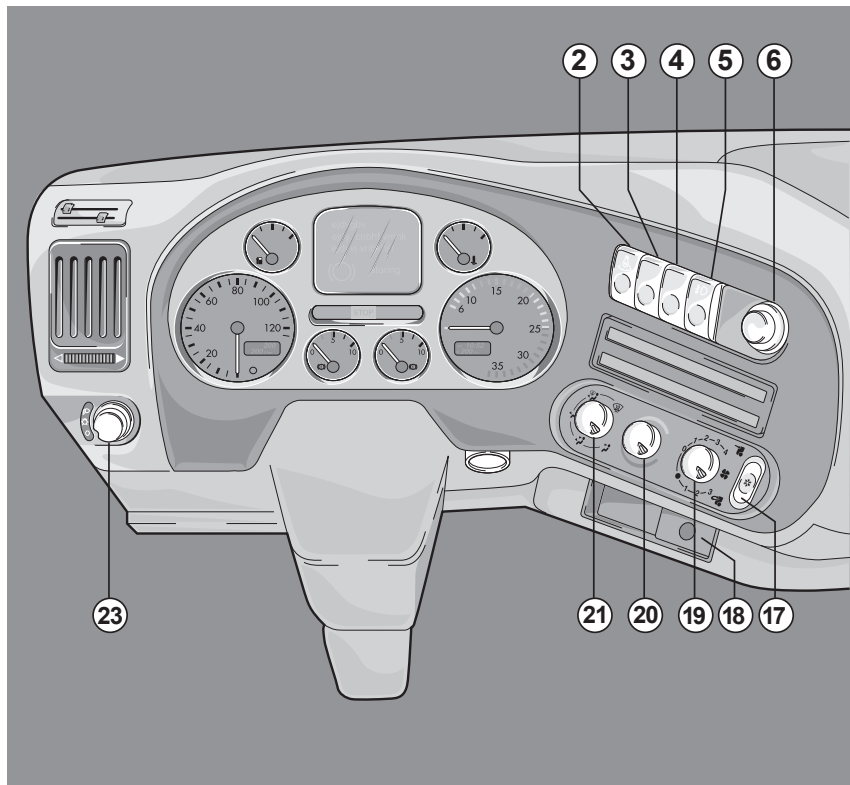

D0 00 705-1

# Cab, Instruments and Controls

---

- 2 Dimmer, dashboard lighting
- 3 (unused)
- 4 (unused)
- 5 Front fog lights
- 6 Master display menu selection switch
- 17 Air conditioning
- 18 12-V connection
- 19 Heater, fan speed selector switch in fresh air position or re-circulation position
- 20 Heater, temperature control
- 21 Heater, air distribution selector switch
- 23 Lighting switch

# Cab, Instruments and Controls



## 2. DIMMER, DASHBOARD LIGHTING

When the lighting is switched on, the dashboard lighting will also illuminate. The setting wheel enables dimming of the lighting.

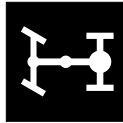

## 3. SWITCH FOR CROSS-AXLE DIFFERENTIAL LOCK

The cross-axle differential lock can be activated with this switch.



### NOTE

This switch has a lock.

The differential lock should be engaged:

- with the vehicle stationary or moving very slowly;
- with the clutch pedal depressed.



### NOTE

For vehicles with automatic gearbox, the vehicle must be stationary and the gearbox in Neutral (N).

See also "DRIVING"

# Cab, Instruments and Controls



## 5. FOG LAMPS, FRONT

There is a two position switch to operate the rear fog lamps.

## 6. MASTER DISPLAY MENU SELECTION SWITCH

See "MASTER DISPLAY".



## 17. AIR CONDITIONING

See "CONTROL PANEL OF HEATING/VENTILATION SYSTEM"

## 18. 12V CONNECTION

There are two auxiliary connections for a 12-V accessory. Accessories connecting to these auxiliary connections should not exceed a combined load of 180 Watts.

## 19, 20, 21. HEATER CONTROLS

See "CONTROL PANEL OF HEATING/VENTILATION SYSTEM"

# Cab, Instruments and Controls

## 23. LIGHTING SWITCH

The vehicle lighting switch is a rotary switch with three positions:

position "0": lighting switched off



position "1": parking and marker lights on



position "2": headlamps, parking and marker lights on





# Cab, Instruments and Controls

## CONTROL PANEL OF HEATING/VENTILATION SYSTEM

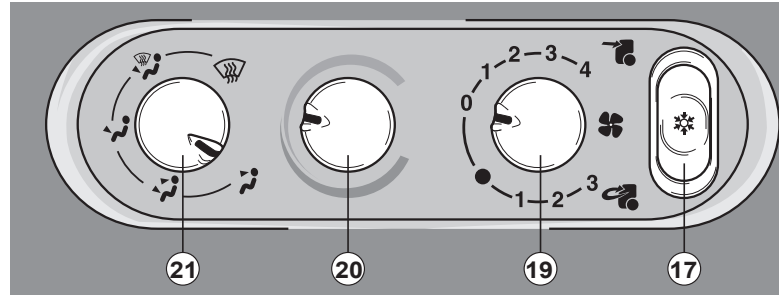

DO 00 672

- 17 Air conditioning
- 19 Fan speed selector switch in fresh air or re-circulation position
- 20 Temperature adjustment
- 21 Air distribution

### **17. AIR CONDITIONING**

See "AIR CONDITIONING SWITCH"

### **19. FAN SPEED**

See "FAN SPEED SELECTOR SWITCH"

### **20. TEMPERATURE CONTROL**

See "TEMPERATURE CONTROL"

### **21. AIR DISTRIBUTION**

SEE "AIR DISTRIBUTION SELECTOR SWITCH"

# Cab, Instruments and Controls

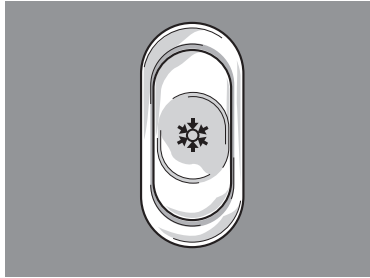

DO 00 566

## AIR CONDITIONING SWITCH

The cab air can be heated, cooled or dehumidified using the air conditioning unit.

The air conditioning unit only functions if:

- the engine is running
- the fan is running.

### Use of the air conditioning

1. When the air conditioning is in use, the windows must remain closed.
2. To reduce the temperature quickly, first use maximum air speed. Later, the air speed can be reduced.
3. Avoid direct cold draught on your body.
4. Make sure that the temperature difference between the inside and outside of the cab does not exceed 40°F (5°C) when you leave the cab. You are therefore advised to switch off the air conditioning towards the end of your journey.
5. Air conditioning consumes extra power and increases the fuel consumption.
6. On extreme angles (slopes, ruts and difficult terrain) switch off the air conditioning, to protect the compressor pump against unlubricated operation.
7. Regularly (once a month) switch on the air conditioning briefly, even if cooling is not required (e.g. in winter). This will help prevent serious damage to the system (including compressor blockage).

# Cab, Instruments and Controls

## Cooling

1. Switch the air conditioning on.
2. Switch the recirculation to position 1, 2 or 3.
3. Turn the temperature control switch to the desired position. For maximum cooling set the knob to the far left position in the blue area.
4. Open the side and center vents.

While heating, it is possible to use the air conditioning to remove moisture from the air in the cab. This has the advantage that demisting of the window glass will be quicker.

## Dehumidification

1. Switch the air conditioning on.
2. Turn the Fan Speed Switch to the Fresh Air setting.
3. Open the vents on the center console and side windows and set them as desired.
4. Control the temperature as desired.
5. Adjust the volume of air using the fan speed selector switch.



### NOTE

The air conditioning system is switched off when the engine coolant temperature becomes too high. This will protect the engine.

# Cab, Instruments and Controls



## **WARNING**

Excessive heat may cause the pressurized components of the air conditioning system to explode. Never weld, solder, steam clean, or use a blow torch near any part of the air conditioning system. Failure to comply may result in personal injury, death, equipment or property damage.



## **WARNING**

Air conditioning refrigerant can be hazardous to your health. Do not expose yourself to leaking refrigerant for prolonged periods near excessive heat, open flames, or without proper ventilation. Failure to do so may result in death or personal injury.



## **NOTE**

If the air conditioning system fails to work properly, it must be repaired by qualified personnel as soon as possible, to avoid further damage to the system.

# Cab, Instruments and Controls

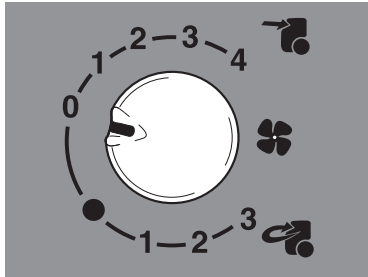

D0 00 644

## FAN SPEED SELECTOR SWITCH

### FRESH AIR POSITION OR RE-CIRCULATION POSITION

The fan has two speeds: one applies to re-circulation the other to fresh air. The re-circulation position is suited to quickly de-mist or cool the cab with the air conditioning, quickly heat the cab, de-frost the windows with the heater and keep out undesirable odors.



#### NOTE

You are advised to switch on the re-circulation without air conditioning for short periods only to prevent the air quality inside the cab from degrading and moisture from increasing.



Fan speeds with fresh outside air ventilation valve open



Fan speeds with re-circulation valve closed, hardly any supply of fresh outside air



D0 00 614

## TEMPERATURE ADJUSTMENT

The supply of heat can be smoothly set from 0% (blue) to 100% (red).





To achieve faster heating when the temperature outside is low, switch on the re-circulation. In damp weather conditions it is recommended to reopen the re-circulation flap after heating to prevent the windows from misting.

# Cab, Instruments and Controls



D0 00 643

## AIR DISTRIBUTION SELECTOR SWITCH

-  Dashboard
-  Dashboard vents and footwell
-  Footwell vent
-  Footwell and windshield vents
-  Defrost

# Cab, Instruments and Controls

## CENTER CONSOLE

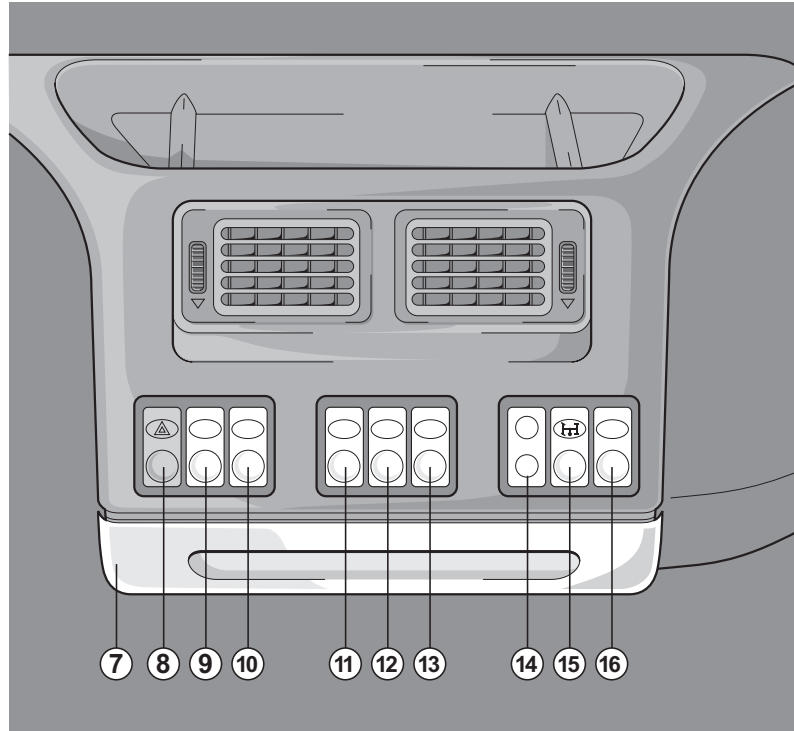

D000706-3

# Cab, Instruments and Controls

---

- 7 Ashtray with 12V auxiliary connection
- 8 Hazard warning lights
- 9 (unused)
- 10 (unused)
- 11 (unused)
- 12 (unused)
- 13 (unused)
- 14 (unused)
- 15 PTO operation
- 16 (unused)



# Cab, Instruments and Controls

## 7. ASHTRAY

In the center console there is an ashtray with auxiliary connection for the driver and co-driver.

Do not connect any accessories above 180 Watt or any combination of accessories that would require a combined amount greater than 180 Watts.

To remove the ashtray, there are two springs on the top of the tray which should be pressed in, after which the tray can be removed.



## 8. HAZARD WARNING LIGHTS

When this switch is pressed, all the direction indicator lights flash simultaneously. The hazard warning lights are switched off by depressing the switch again. The warning light in the switch indicates that the hazard warning is switched on.

## 9. (unused)

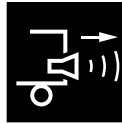

## 11. (unused)



## 13. (unused)

## 15. PTO OPERATION

With this switch, the Power Take Off can be engaged, if necessary in combination with the variable speed engine control. Engage the PTO only when the programmed engaging conditions are met.

# Cab, Instruments and Controls

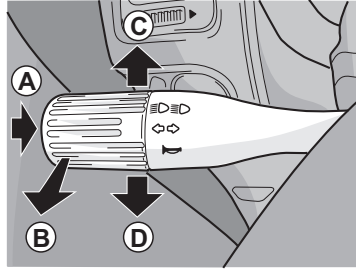

D0 00 600

## LEFT-HAND STEERING COLUMN SWITCH

- A Horn
- B Main beam
- C Direction indicator, right
- D Direction indicator, left

### A. HORN

The horn is operated with button A.

### B. MAIN BEAM

Position B: The main beam is activated when the lights are on. The main beam indicator on the instrument panel will also light up. To switch off the main beam, the switch must be turned back through the "click" position towards the steering wheel. If the lights are off, or if the switch has not been pushed through the "click" position, it can be used to give signals.

### C. DIRECTION INDICATOR, RIGHT

Position C: Right turn signal: on the instrument panel, the right direction indicator will flash and there will also be an audible signal. To briefly operate the direction indicators (changing lanes, etc.), the switch can be pushed slightly against the spring pressure. It will spring back when released.

### D. DIRECTION INDICATOR, LEFT

Position D: Left turn signal: on the instrument panel, the left direction indicator will flash and there will also be an audible signal. To briefly operate the direction indicators (changing lanes, etc.), the switch can be pushed slightly against the spring pressure. It will spring back when released.

# Cab, Instruments and Controls

## RIGHT-HAND STEERING COLUMN SWITCH

The right-hand steering column switch has the following functions:

- 1 Position 1: Intermittent wipe.
- 2 Position 2: Wipe speed (low).
- 3 Position 3: Wipe speed (high).
- 4 Position A: Wipe/wash.

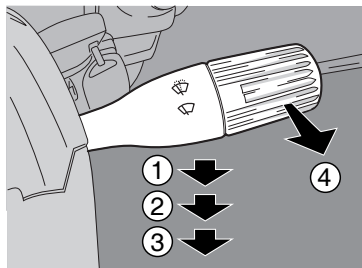

D001199

# Cab, Instruments and Controls

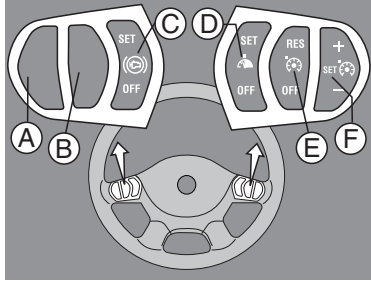

D0 01 190-3

## STEERING WHEEL SWITCHES

Depending on the vehicle version, the steering wheel either has or does not have steering wheel switches.

### Left-hand switches

A (unused)

B (unused)

C Engine brake

### Right-hand switches

D Variable speed limiter

E Cruise control, resume, off

F Cruise control setting/engine speed control

# Cab, Instruments and Controls

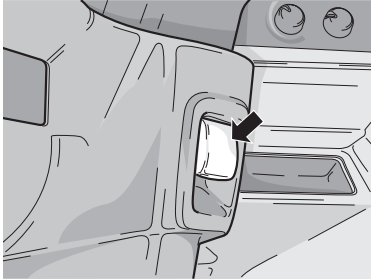

D0 00 61€

## ADJUSTABLE STEERING COLUMN

The position of the steering column is adjustable. To adjust, pull the handle towards you and simultaneously move the steering column to the desired position. The steering column is locked by releasing the handle. A pneumatically adjustable steering column is available as an option.



### WARNING

**Make all adjustments to the steering mechanism while the vehicle is stopped. Adjusting the Tilt-Telescoping Steering Wheel while the vehicle is in motion could cause loss of control. You wouldn't be able to steer properly and could have an accident resulting in personal injury or death.**

Seats

# Seats

---

## IMPORTANT POINTS



### WARNING

**Make all adjustments to the steering mechanism while the vehicle is stopped. Adjusting the Tilt-Telescoping Steering Wheel while the vehicle is in motion could cause loss of control. You wouldn't be able to steer properly and could have an accident resulting in death or personal injury.**

- You must read this section thoroughly and acquaint yourself with the seat controls.
- The vehicle air pressure must be a minimum of 100 PSI 7 bar.
- Never operate several controls at once.
- The armrest should be folded away before entering/leaving the vehicle.
- The co-driver's seat is not suitable for a child's seat.
- The seat and its component parts must be checked for wear from time to time.
- The seat may only be repaired by trained personnel.

# Seats

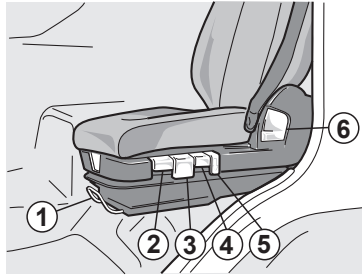

DO 00 694-1

## Driver's seat

Operation:

- 1 Seat fore/aft adjustment
- 2 Shock absorber setting: The suspension characteristics of the seat (in terms of comfort) can be optimized by means of the infinitely adjustable shock absorber (from "hard" to "soft") for each driving situation.
  - Position switch up: minimum damping ("soft" comfort)
  - Position switch down: maximum damping ("hard" comfort)



### NOTE

The shock absorber must always be set tight enough to withstand conditions on a poor road surface.

- 3 Seat squab angle adjustment
- 4 Seat height adjustment
- 5 Entry/exit aid
  - Knob down (seat in driving position): seat drops to its lowest position (= entry/exit aid)
  - Knob up (with lowered seat): seat returns to the last set height
- 6 Backrest angle adjustment.



# Seats

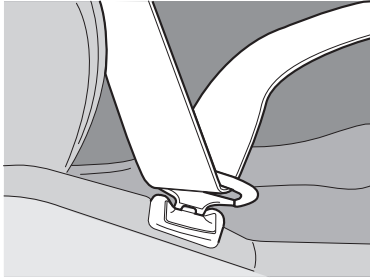

D000534

## SEAT BELTS

### Safety Restraint System - Inspection

The seat belt system, including webbing, buckles, latches, and mounting hardware, endures heavy use in heavy-duty vehicles, much more than seat belt systems in passenger cars. All users should be aware of the factors contributing to this heavy use and reduced belt life.



#### **WARNING**

**Failure to properly inspect and maintain restraint systems can lead to injury or loss of life. Without periodic inspection and maintenance to detect unsafe conditions, seat restraint components can wear out or not protect you in an accident.**

Factors contributing to reduced seat belt life:

- High mileage heavy trucks, often accumulate mileage in excess of 500,000 total miles (800,000 km) during the vehicle lifetime. This is much greater than a typical passenger car, which frequently will not exceed 125,000 total miles (200,000 km).
- Seat and cab movement in trucks, there is almost constant movement of the belt due to ride characteristics and seat design. The constant movement of the belt inside the restraint hardware and the potential for the belt to come in contact with the cab and other vehicle parts, contributes to the wear of the entire system.
- Environmental conditions, such as dirt and ultraviolet rays from the sun, will reduce the life of the seat belt system.

# Seats

Due to these factors, the three-point safety belt system installed in your vehicle requires thorough inspection every 20,000 miles (32,000 km). If the vehicle is exposed to severe environmental or working conditions, more frequent inspections may be necessary. Any seat belt system that shows cuts, fraying, extreme or unusual wear, significant discoloration due to UV (ultraviolet) exposure, abrasion to the seat belt webbing, or damage to the buckle, latch plate, retractor hardware or any other obvious problem should be replaced immediately, regardless of mileage.



## **WARNING**

**It is important to remember that any time a vehicle is involved in an accident, the entire seat belt system must be replaced. Unexposed damage caused by the stress of an accident could prevent the system from functioning properly the next time it is needed. Failure to comply may result in personal injury or death.**

## **Inspection Guidelines**

Follow these guidelines when inspecting for cuts, fraying, extreme or unusual wear of the webbing, and damage to the buckle, retractor, hardware, or other factors. Damage to these areas indicates that belt system replacement is necessary.



## **WARNING**

**Replace the entire belt system (retractor and buckle side) if replacement of any one part is necessary. Unexposed damage to one or more components could prevent the system from functioning properly the next time it is needed. Failure to comply may result in personal injury or death.**

# Seats

1. Check the web wear in the system. The webbing must be closely examined to determine if it is coming into contact with any sharp or rough surfaces on the seat or other parts of the cab interior. These areas are typical places where the web will experience cutting or abrasion. Cuts, fraying, or excessive wear would indicate the need for replacement of the seat belt system.
2. The pillar web guide (D-loop) is the area where almost constant movement of the seat belt webbing occurs because of relative movement between the seat and cab.
3. Check the Comfort Clip for cracks or possible damage and check for proper operation.
4. Check buckle and latch for proper operation and to determine if latch plate is worn, deformed, or damaged.
5. Inspect the retractor web storage device, which is mounted on the floor of the vehicle, for damage.

The retractor is the heart of the occupant restraint system and can often be damaged if abused, even unintentionally. Check operation to ensure that it is not locked up and that it spools out and retracts webbing properly.

6. If tethers are used, be sure they are properly attached to the seat and, if adjustable, that they are adjusted in accordance with installation instructions. Tethers must also be inspected for web wear and proper tightness of mounting hardware.
7. Mounting hardware should be evaluated for corrosion, and for tightness of bolts and nuts.
8. Check web in areas exposed to ultraviolet rays from the sun. If the color of the web in these areas is gray to light brown, the physical strength of the web may have deteriorated due to exposure to the sun's ultraviolet rays. Replace the system.

# Seats

## Seat Belt Inspection Points

1. Web cut or frayed or extremely worn at latch area.
2. Web cut or frayed at D-loop web guide.
3. Comfort Clip cracked or damaged.
4. Buckle casting broken.
5. Retractor Web Storage for damage. (located behind trim panel)
6. Tethers for web wear and proper tightness of mounting hardware.
7. Mounting hardware for corrosion, proper tightness of bolts and nuts.
8. Web for deterioration, due to exposure to the sun.



### **WARNING**

**Failure to adjust tether belts properly can cause excessive movement of the seat in an accident. Tether belts should be adjusted so that they are taut when the seat is in its most upward and forward position. Failure to comply may result in personal injury or death. Once the need for replacement of the seat belt has been determined, be certain it is only replaced with an authorized PACCAR Parts replacement seat belt. If the inspection indicates that any part of the seat belt system requires replacement, the entire system must be replaced. An installation guide is attached to every replacement belt. Utilize the proper guide for your type of seat, and follow the instructions very closely. It is vitally important that all components be reinstalled in the same position as the original components that were removed and that the fasteners are torqued to specification. This will maintain the design integrity of the mounting points for the seat belt assembly. Contact your dealer if you have any questions concerning seat belt replacement.**

# Seats

---

## **Wearing seat belts**

- The belt must be tight against the body and not distorted.
- With a three-point type belt, the shoulder section must be across center of the shoulder, not against the neck. The pelvis section should be as low as possible across the pelvis, not across the abdomen.
- Do not put any hard, sharp or fragile objects such as pens, glasses or phones between your body and the seat belt.

## **Checking the seat belts**

- Give a short pull on the seat-belt to test the locking mechanism.
- Repeat this check regularly, for example when putting on the seat belt, in order to check the mechanism.

During this test, the belt must lock. This means that it must not be possible to pull the seat belt out of the retracting unit after locking.

The locking mechanism should be immediately replaced and/or repaired if it is defective.

- Inspect the belts regularly for wear. Have the complete assembly replaced at once if the belt is worn or damaged.

## Master Display

# Master Display

---

## **GENERAL**

In the master display a menu can be displayed to show the driver all the information regarding the function and operation of the various systems in as useful a way as possible.

The master display is a part of the Central Warning System. In addition, the system contains a menu selection switch, a buzzer and a central "STOP" warning lamp under the master display.

The master display consists of three different fields; an indication bar, an information screen (yellow or red) and an information screen (yellow).

# Master Display

## LAYOUT OF MASTER DISPLAY

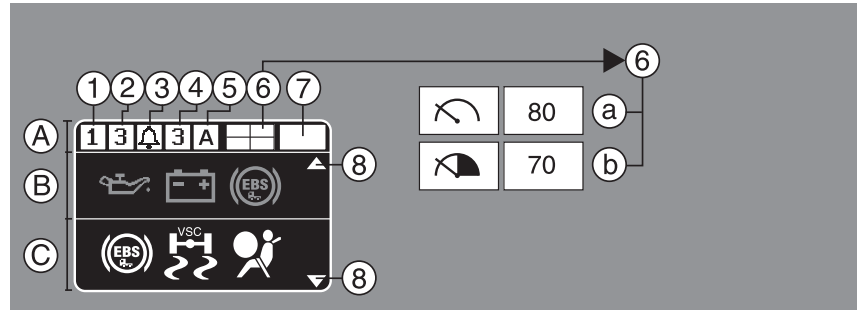

D001192-3

- A Indication bar
- B Information screen (yellow and red)
- C Information screen (yellow)
- 1 Number of active red warnings
- 2 Number of active yellow warnings
- 3 Alarm function engaged
- 4 Gear engaged, AS Tronic Lite or automatic gearbox (AGC-A)
- 5 Speed set
- 6 Vehicle speed setting functions (review)
- 7 (unused)



# Master Display

## START-UP PHASE

If the ignition has been switched on and the engine is not yet running, the start-up screen is shown in the master display.

The following warning symbols, if present, are then displayed:

- Oil pressure (red)
- Alternator voltage (red)
- Steering circuit 1 output (red)
- ABS of prime mover (yellow)



### NOTE

When starting a vehicle equipped with an Allison automatic gearbox, the transmission fault warning symbol appears in the main display; this symbol disappears once the engine is started.

During the start-up phase, the "STOP" warning lamp and the acoustic signal are inactive.

Approximately 3 seconds after switching on the ignition, the yellow warning symbols will disappear. During these 3 seconds, no other warnings can be displayed.

The red warning symbols should disappear from the screen approximately 2.5 seconds after the engine has been started.

If the oil pressure, charging voltage or steering circuit 1 output is still too low after these 2.5 seconds, the warning screen will become active, in which the relevant red warning symbol appears with the accompanying text. The "STOP" warning lamp and audible alarm will also be activated.

# Master Display

---

If there is a less serious fault, the respective yellow symbol with the accompanying text will appear on the screen and an acoustic signal will be heard for a certain time.

If the indication bar mentions several red and/or yellow warnings, the other warnings can be called up by turning the menu selector switch one step further each time. This takes place in order of priority. This means that the most important warning will be displayed first.

A red warning cannot be removed from the screen when the engine is running.

The red warning symbol can be turned off when the engine is not running. This is so that it is possible to use other menu options (if you return to the main screen, the warnings will re-appear).

Yellow warnings can be switched off at any time.

The message detailing the number of warnings present remains active at all times. A continuous audible alarm tone accompanies a red warning.

A pulsating audible alarm tone accompanies a yellow warning and sounds four times.

# Master Display

## MENU SELECTOR SWITCH

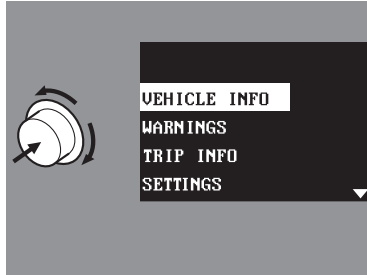

D000711

By pressing the menu selector switch, the main menu will be selected and the selector bar will become visible.

Turning the menu selector switch will switch between screens in the main menu. The triangle on the right-hand side of the display shows the direction in which you can proceed.

By pressing the menu selector switch, the function/information chosen will be selected, after which sub-menu 1 will appear, if present. If there is no sub-menu 1, the menu function will be turned off.

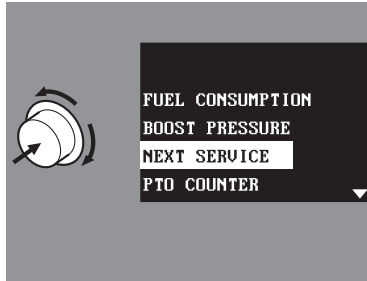

D000555

By turning the menu selector switch you will browse through sub-menu 1.

The triangle on the right-hand side of the display shows the direction in which you can proceed.

By pressing in the menu selector switch, the function/information chosen will be selected, after which sub-menu 2 will appear, if present. If there is no sub-menu 2, the menu function will be switched off.

# Master Display

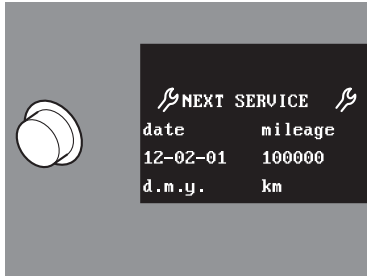

D000556

By turning the menu selector switch, sub-menu 2 can be accessed.

The triangle on the right-hand side of the display shows the direction in which you can proceed.

By pressing the menu selector switch, the menu function will be switched off.

# Master Display

## MENU OVERVIEW

Main menu	Sub-menu 1	Sub-menu 2
Vehicle information	Fuel consumption	- Current - Average - Average trip
	Turbocharger pressure	
	Oil level	
	Service inspection	- Date - Distance
	PTO counter	- PTO 1 counter - PTO consumption
	Chassis number	
	Back	
Faults	All faults	
	Back	

# Master Display

Main menu	Sub-menu 1	Sub-menu 2
Trip info	Trip info	<ul style="list-style-type: none"> <li>- Distance</li> <li>- Time</li> <li>- Average speed</li> <li>- Average consumption</li> <li>- Fuel consumption</li> </ul>
	Trip reset	
	Close	
Settings	Language 1 or 2	
	Alarm on/off	
	Setting alarm	<ul style="list-style-type: none"> <li>- Setting alarm: hours</li> <li>- Setting alarm: minutes</li> <li>- Alarm time</li> </ul>
	Time, local/home	
	Set local time	
	Clock AM/PM/24H	
	Display miles/km	
	Close	
Close		

# Master Display

## FAULTS

### Serious fault

A red warning symbol is activated when there is a serious fault.

When a red warning symbol is activated, the "STOP" warning lamp and an audible alarm are activated at the same time.



#### **WARNING**

**This should be considered an emergency. You should stop the vehicle as safely as possible and turn OFF the ignition. The vehicle must be serviced and the problem corrected before driving again. Failure to do so may cause severe engine or DPF damage, or cause an accident which may result in personal injury or death.**

### Less serious fault

A yellow warning symbol is activated if there is a less serious fault.

When yellow warnings appear you may continue driving but action must be taken at the first opportunity to remedy the fault. Have an authorized Service dealer correct the problem as soon as possible.



#### **WARNING**

**As the vehicle may behave differently from normal, the vehicle must be driven with extra caution.**

# Master Display

## WARNING SYMBOLS

### Red warnings



#### Oil pressure low

If the oil pressure suddenly drops, or the audible alarm and engine oil pressure warning light come on while driving, do the following:

1. Slow down carefully.
2. Move a safe distance off the road and stop.
3. Place the transmission in park and set the parking brake. (See Stopping on page 112 and Automatic Gearbox on page 128-134, for transmission shifting and parking brake information.)
4. Turn OFF the engine.
5. Turn ON the emergency flasher and use other warning devices to alert other motorists.
6. Wait a few minutes to allow oil to drain into the engine oil pan, and then check the oil level. (See "ENGINE OIL LEVEL" in "INSPECTIONS AND MAINTENANCE" on [page 93](#), for details on checking oil level.)
7. Add oil if necessary. If the problem persists, contact an authorized dealer as soon as possible.



#### CAUTION

**Continuing to operate your vehicle with insufficient oil pressure may cause severe engine damage or cause an accident which may result in equipment or property damage. It is important to maintain oil pressure within acceptable limits. If oil pressure drops below the minimum psi a Red Warning Lamp on the oil pressure gauge and the Stop Engine Lamp will come ON.**



# Master Display



## **Cab lock open**

See "Cab tilting" in "EMERGENCY REPAIRS".



## **Air pressure low**

This warning symbol is active when the pressure in one of the service brake circuits is lower than 65 psi or 4.48 bar.



## **Coolant Level Low**

This warning symbol will come on when the coolant level is below the minimum permissible level. Check the coolant level (caution – danger of scalding; see "Topping up coolant" in "INSPECTIONS AND MAINTENANCE")

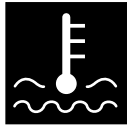

## **Coolant temperature high**

This warning symbol will come on when the coolant temperature exceeds the maximum permissible value. Check the following points:

the coolant level (caution – danger of scalding; see "Topping up coolant" in "INSPECTIONS AND MAINTENANCE");  
the poly V-belt and water hoses; the fan clutch.

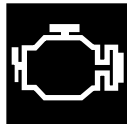

## **Engine fault**

Serious fault in the electronic unit.



## **Transmission fault**

If the vehicle is equipped with an automatic gearbox, see "Faults" in "AUTOMATIC GEARBOX".

# Master Display

## Yellow warnings



### Truck ABS fault

This symbol is activated when:  
there is a fault in the ABS of the prime mover;

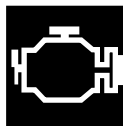

### Engine fault

Depending on the fault, the engine can switch over to emergency control.

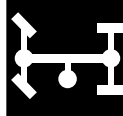

### PTO fault

Engine speed control does not meet the conditions. See "Engine speed control" in "DRIVING".



### Oil pressure low

Check the engine oil level See also "Daily inspections" in "INSPECTIONS AND MAINTENANCE".



### Water separator fuel filter

Check the fuel prefilter/water separator. See "Weekly inspections" in "INSPECTIONS AND MAINTENANCE".

# Master Display



**No warning**



## **Coolant level sensor**

This symbol will light up if the coolant level sensor is not latched into its proper position. The sensor is part of the filler cap.

## **Key to abbreviations**

ABS	Anti-lock Braking System
PTO	Power Take Off
VIC	Vehicle Intelligence Center

## Inspections and Maintenance

# Inspections and Maintenance

## OVERVIEW OF DAILY CHECKS

Overview of the driver's daily checks:

- engine oil level
- coolant level, fill cap secure
- fluid level in windshield washer reservoir
- air filter indicator
- tires and rims
- lighting and instruments
- driver's seat and mirrors
- trailer

Visual check before starting the trip:

- check that no situation can occur (such as loose objects, improperly attached load etc.) that may put other road users at risk.



### NOTE

Cleaning rags, flammable materials, accumulated dirt etc. in the vicinity of the exhaust system must be removed as these create a fire hazard.

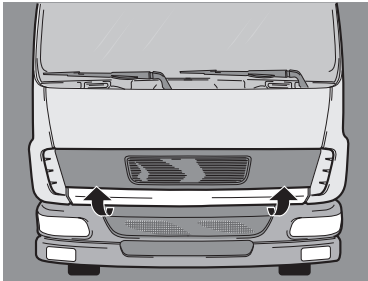

D000695

## OPENING THE FRONT PANEL

Open the front panel by gripping it at the bottom and lifting it up. The front panel will tilt upwards and is held in place by two gas struts.

# Inspections and Maintenance

## ENGINE OIL LEVEL

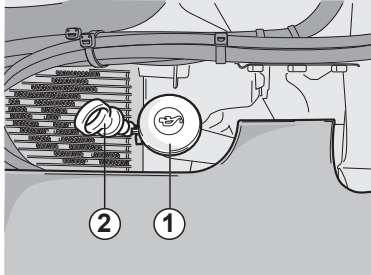

D0 00 721



### NOTE

It takes approx. 20 minutes for all the oil to run into the sump when the engine is "warm". If the dipstick is checked immediately after switching the engine off or immediately after oil has been added, the level shown on the dipstick will be too low.

6. Fill oil through the filler opening (1) until the oil level reaches the maximum mark. Only use engine oil that meets specifications. See "TECHNICAL DATA".



### NOTE

For the difference between the minimum and maximum engine oil level, see "TECHNICAL DATA".

# Inspections and Maintenance

## TOPPING UP COOLANT



### WARNING

When the coolant is hot, there is an overpressure in the cooling system. If circumstances dictate that it is necessary to top up the coolant when the engine is warm, unscrew the filler cap carefully one turn to relieve the overpressure. Take adequate precautions against burning by, for example, placing a cloth over the cap. Coolant is a toxic fluid. Contact with the skin should therefore be avoided. Also see "Lubricant, engine coolant and fuel specifications" in "TECHNICAL DATA"



### WARNING

To prevent damage to the engine block, topping up with cold coolant when the engine is hot must be done slowly and with the engine running.



### WARNING

Do not loosen the filler cap of the cooling system when the cab is tilted. The filler cap houses the coolant level sensor. Take necessary precautions to protect the sensor from damage when removing it.

# Inspections and Maintenance

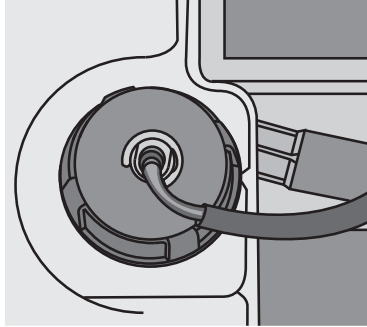

D0 02 003

1. Turn the rotary knob for the heating temperature control to "maximum hot".
2. Open the front panel.
3. Remove the black filler cap from the cooling system reservoir.
4. Run the engine for several minutes.
5. Stop the engine and check the coolant level.
6. If necessary, top up to the bottom of the filler opening.

Always use **coolants** which meet specifications. See "TECHNICAL DATA".



## NOTE

Take care not to damage the coolant level sensor when removing and replacing the reservoir filler cap.





# Inspections and Maintenance

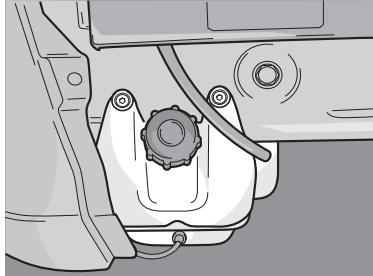

D0 00 608

## WINDSHIELD WASHER RESERVOIR FLUID LEVEL

1. Open the front panel.
2. Check the fluid level in the screen washer reservoir.
3. Top up, if necessary, via the filler opening.



### NOTE

When topping up, it is recommended to add a windshield cleaner to the water in the windshield washer reservoir.

During the winter period, add windshield wash antifreeze.

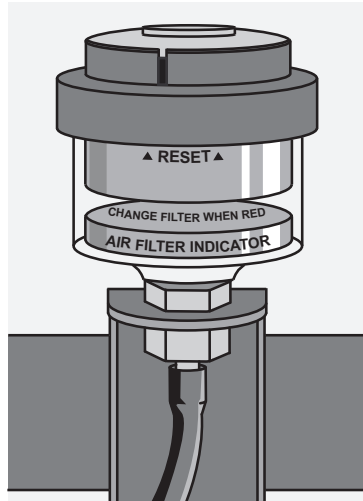

D0 02 004

## AIR FILTER INDICATOR

The air filter indicator is behind the grille at the front of the cab. If the indicator is in the red area (showing the text "service"), the air filter is seriously fouled and must be replaced. Consult an authorized Service dealer. Clogged air filters lead to increased fuel consumption and loss of power.

# Inspections and Maintenance

## WHEELS AND TIRES

- Remove any stones, etc. from the tread and from between the tires (if twin wheels are fitted).
- Check for evidence of wear and damage and for nails or other foreign objects caught in the tires.
- Check the attachment of the wheels.
- Check the tire pressures (do not forget the spare wheel). The tire pressures should be checked and corrected while the tires are cold. See chapter on "Technical data" or the back page of this book for the correct tire pressures.



### NOTE

If a worn tire is underinflated by 30 psi, the ABS control will be inoperative under extreme conditions! Also see "Changing the wheel" in the "EMERGENCY REPAIRS" section of this manual.

## LIGHTING AND INSTRUMENTS

- Check the vehicle lighting, brake lights and instruments for correct operation.
- Also check the operation of the horn, windshield wipers and washers.

# Inspections and Maintenance

## DRIVER'S SEAT AND MIRRORS

Set the seat and mirrors to the correct positions.

Mirrors with field of vision projected on the ground

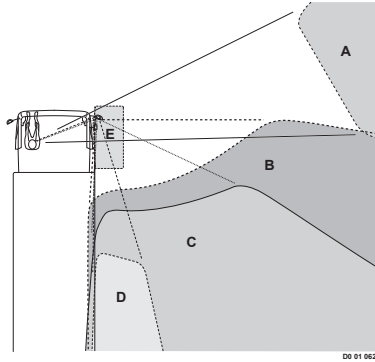

- A Side window
- B Dead angle mirror
- C Wide view mirror
- D Main mirror
- E Pavement mirror

## OVERVIEW OF WEEKLY CHECKS

Overview of the driver's weekly checks:

- clutch fluid level
- Power steering fluid level
- Brake system air drier
- Draining the fuel system water separator
- Batteries

# Inspections and Maintenance

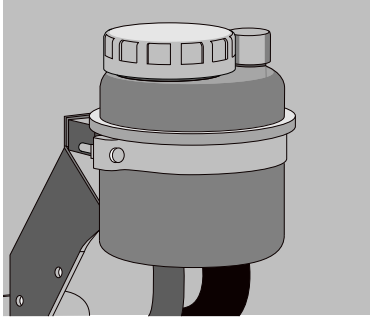

DO 00 581-1

## POWER STEERING FLUID LEVEL

1. Tilt the cab.
2. Clean the dipstick and its immediate surroundings to prevent any dirt from entering the reservoir.
3. Check the fluid level in the reservoir using the dipstick.
4. The fluid level must be between the two marks.
5. Top up oil, if necessary, via the filler opening. Oil type: see "TECHNICAL DATA".
6. If the level is below the minimum mark, this is a sign of leakage. Contact an authorized Service dealer as soon as possible.

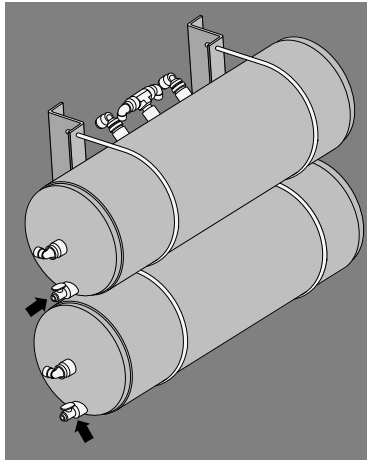

DO 00 592-1

## BRAKE SYSTEM AIR DRIER

The air drier can be checked for correct operation by inspecting the air reservoirs for condensed water.

1. Check the air reservoirs for condensed water by pulling on the rings of the drain valves.
2. If repeatedly more than the normal amount of water is drained off, the air drier element will have to be replaced. Consult your Service dealer.

# Inspections and Maintenance

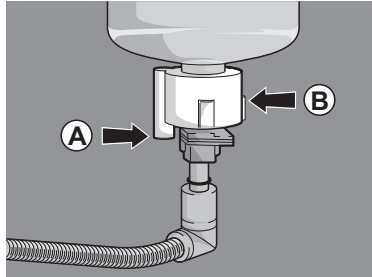

DO 00 620

## DRAINING THE WATER SEPARATOR



### WARNING

When draining the water separator, an amount of fuel will escape. Collect the fuel and avoid the risk of fire.

Water in the fuel system may lead to significant damage.

1. Place a container beneath the water separator.
2. Remove the connector.
3. Unscrew the ring-shaped drain cock (B) on the bottom of the water separator in anti-clockwise direction.
4. Drain the filter until pure diesel fuel comes out of the drain cock (A).
5. Turn the drain cock (B) if it abuts, another 1/8 - 1/4 turn.
6. Check the drain cock (B) for leakage.
7. To prevent pollution, the drained water/diesel fuel mixture should be passed to the relevant authorities for reprocessing.

# Inspections and Maintenance

## BATTERIES

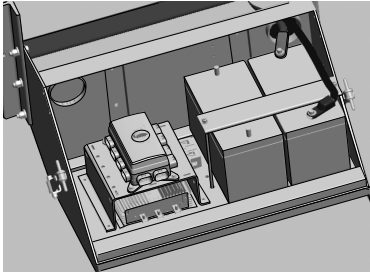

DO 00 627-1



### WARNING

**Avoid sparks and open flames in the vicinity of batteries.**

**Battery acid is an aggressive fluid.**

**In the event of contact with the skin: rinse the skin profusely with plenty of water.**

**Consult a doctor in the event of persistent redness or pain.**

**Remove polluted clothing and rinse in water.**

**In the event of contact with the eyes: rinse with plenty of water for at least 15 minutes and consult a doctor.**

**If swallowed: do NOT induce vomiting. Rinse the mouth, drink two glasses of water and consult a doctor.**

**In the event of inhalation: get fresh air, rest and consult a doctor.**

- Check the electrolyte level; this should be approx. 10 mm above the plates or up to the level indicator, if present. If necessary, top up the batteries with distilled water.
- Check that the battery poles and terminals are clean and greased. If necessary, coat the posts with an acid-free petroleum jelly.

# Inspections and Maintenance

---

## GENERAL MAINTENANCE

The durability, safety, trade-in value and reliability of your vehicle largely depend on the care you give it. This includes regular service in accordance with the maintenance schedules specified.

The driving style of the person at the wheel and the care given to the vehicle will have a direct influence on the condition of the vehicle. The driver can often provide the dealer with information which is very important for correct maintenance.

Prior to the service intervals and the related activities, contact your authorized Service dealer.

## CAB MAINTENANCE

In order to keep this quality as high as possible, during vehicle use, regular maintenance should be carried out on the cab surfaces.

To prevent the formation of rust in box sections and other cavities, the cab is protected with corrosion-inhibiting products (ML) in production.

**Due to the setting of the structure, minor bare spots may develop in this additional protective coating. For this reason, the manufacturer considers it necessary to have further treatment carried out within a specific period (consult the warranty manual) after the vehicle has been taken into service.**

**If this does not happen, the warranty will become invalid.**

**The relevant warranty conditions are listed in the warranty manual.**



# Inspections and Maintenance

---

## CLEANING

### Cleaning the vehicle

Before the vehicle is cleaned, check for leaks in the engine, axles, gearbox, etc. This is no longer possible after cleaning the vehicle and carrying out maintenance work.

When a high-pressure cleaner is used, take special note of the following points:

- Make sure that the doors, windows and roof hatch are properly closed.
- Never spray directly on seals. There is a danger of them being forced open so that water can penetrate or grease packed behind them is flushed away. This may happen, for example, with the universal joint on the steering box. As a result, the spider may seize so that the steering will jam.
- Do not spray directly onto steering ball joints.
- The power steering fluid reservoir is fitted with a vent. Water may enter the reservoir via this vent, which will cause damage to the steering gear.
- When cleaning the radiator/intercooler, take care not to damage the fins.
- Do not direct the high-pressure cleaner/steam cleaner jet too long at the air-conditioning system condenser. As a result of the high temperature, the pressure in the system will rise too high, which may cause damage to the system. Parts of the air-conditioning must not be cleaned with the aid of a high-pressure/steam cleaner as this can cause damage to the seals.
- Make sure that no water can enter the differential and gearbox via the vents.
- Make sure that no water can enter via the reservoir bleed screws of the clutch, brakes, trailing axle, etc.

# Inspections and Maintenance

- The engine and engine compartments can be cleaned with a high-pressure/ steam cleaner. Avoid spraying directly onto electrical components such as the fuel system pump units, electronic units the starter motor, alternator, air-conditioning compressor, headlights, etc.
- Carefully clean the engine encapsulation and its fittings. Remove any spilled oil and diesel oil to avoid the risk of fire.
- Do not aim the jet of water directly at electrical connections such as connectors, cable plugs in the vehicle lighting system, etc. Also do not aim the jet at the gear lever unit.
- When cleaning the vehicle, make sure that no water can enter the air inlet system via the air intake or its flexible seals.
- When the vehicle has been cleaned, it must be lubricated again with a grease gun or via the automatic lubrication system. This is important because it prevents the penetration of moisture and dirt at the various pivot points.

## **Cleaning the cab**

Depending on the vehicle's operating conditions, the external paintwork of the cab is subject to attack by corrosive substances, for example road salt, grit and polluted air. For instance, road salt and air pollution.

The paintwork must therefore be cleaned regularly.

When cleaning the cab, make sure that:

- no caustic cleaners are used
- no hard brushes are used
- all seams, gaps and door shut-lines are thoroughly cleaned.

# Inspections and Maintenance

## **Waxing the cab**

The paintwork of new vehicles is waxed to protect it against the elements.

After a time this wax coating will gradually wear away as a result of cleaning and other external influences.

To give corrosive substances less chance of attacking the paint, it is advisable to protect the paintwork with a new wax coating at least twice a year.

It is advisable to use wax for this.

Your authorized Service dealer can advise you about additional anti-rust treatment and maintenance of the paintwork when the vehicle is in service.

## **Cleaning the interior**

The day cab can be fitted with fabric or plastic trimming.

The sleeper cab is only available with fabric trimming.

The plastic can be cleaned with a household cleaning agent and warm water.

The fabric trimming should be cleaned with a non-aggressive dry-cleaning agent, or an equivalent product.



### **NOTE**

The appearance of your vehicle is your company's face to the world!

# Inspections and Maintenance

## PREVENTATIVE MAINTENANCE BEFORE THE WINTER SEASON

Your authorized Service dealer can always give you good advice to prepare your vehicle for winter.

### DIESEL FUEL

If outside temperatures are persistently low, only fill up with winter diesel oil produced by a reputable oil company.

During the winter months the oil companies often use additives, to prevent blockages caused by the precipitation of paraffin crystals (wax deposits).

It is **not** permitted to use **your own** fuel additives.



#### NOTE

Additives which are used to prevent precipitation of paraffin crystals have a **purely preventative** effect. They can **not** dissolve the paraffin crystals once they have been precipitated.

**Always** carry a spare fuel fine filter in the vehicle so that you can replace it quickly if it becomes blocked in any way (for example, by paraffin crystals).

**Always** preferably fill up in the evenings to prevent condensation (especially in winter).

# Inspections and Maintenance

---

## **CAB HEATER**

If necessary, install a separate fuel tank for the cab heater.

If the tank has been filled up with winter diesel oil because of a cold weather period or a trip to a colder country, allow the cab heater to run on the new fuel for half an hour to ensure that all the old fuel has been used up.

The above recommendations apply for both air and water heating and for all vehicle types.

## **WINDSHIELD WASHER RESERVOIR**

- When topping-up, it is advisable to add a cleaner to the water in the windshield washer reservoir.
- During the winter period, add windshield wash antifreeze.

## **MAINTENANCE AFTER THE WINTER SEASON**

**Your authorized Service dealer can always give you good advice to prepare your vehicle for summer.**

## **COOLING SYSTEM**

The coolant may be left in the cooling system during the summer.

## PDC & Voltage Converter

# PDC & Voltage Converter

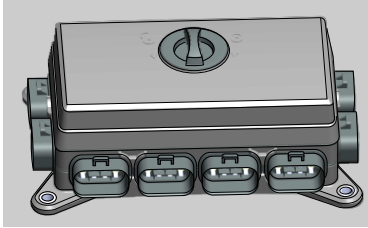

D0 02 012

## POWER DISTRIBUTION CENTER

### Power Distribution Center (PDC)

The PDC provides a fused 24V/12v to the cab and controls 12V to chassis systems, inside of the box and relays 12V to chassis and cab systems.

PDC box has the following Specifications:

- 400 amps max output
- 64 I/O pins (color coded)
- 4 power input terminals
- Customer configurable
- PACCAR branded
- Component labeling

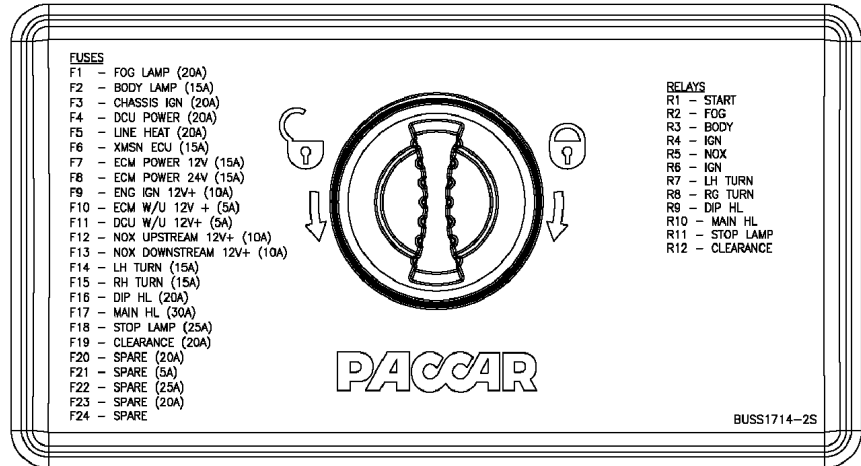

# PDC & Voltage Converter

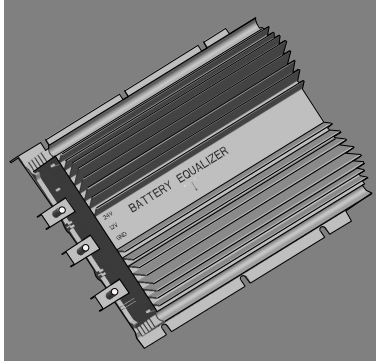

D0 02 013

## **Voltage converter.**

The Voltage converter provides 24V to cab systems. It is located in the battery box.

Below to the PDC support. The Voltage converter has the following Specifications:

- 12V input - 24V output
- Input current: 90 amps
- Output current: 45 amps
- Temperature range: -40C to+85C





Driving

# Driving

---

## GENERAL

### **Before setting out on a journey, always check:**

- vehicle for possible water or oil leaks
- engine oil level
- fluid level in the screen washer reservoir
- air filter indicator
- coolant level
- drawn vehicle coupling for correct attachment and correct operation
- connection and operation of the drawn vehicle lighting and brakes
- wheel attachment and tire pressures
- tread depth of tires
- tread of each tire for even distribution of wear pattern
- correct setting of seat and mirrors
- correct operation of lights and instruments
- fuel level

### **After each journey check that:**

- doors of the vehicle are locked
- load is still properly secured

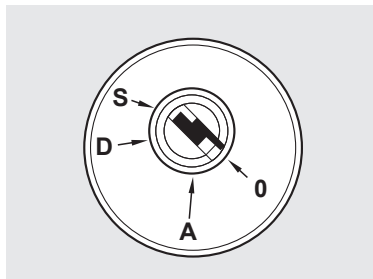

D000970

## STEERING LOCK/CONTACT/STARTER SWITCH



### WARNING

**NEVER** turn the ignition key to the rest position (0) or remove it while the vehicle is in motion. This may cause the steering wheel lock to engage.

### Position 0: rest position

When the key is removed in this position the steering wheel can be locked.

If the steering wheel is turned slightly the steering wheel will lock.

### Position A: accessories position

Steering wheel unlocked. The key cannot be removed. Accessories, such as a radio, can be switched on.

### Position D: ignition turned on

All power consumers can be switched on.

### Position S: starting

When the key is released, it automatically returns to position D.

If the engine is running, the start lock is switched on.

## GLOW SYSTEM

If the ignition is on, the electronic unit determines the necessary pre and after glow time.

The necessary pre- and after glow time depends on the temperature that is measured by the electronic unit of the engine management system.

If the pre- or after glow time is activated by the electronic unit, a warning lamp on the instrument panel lights up.

## STARTING PROCEDURE



### WARNING

If you start the engine inside a building, open the doors fully to ensure adequate ventilation. Exhaust gases contain carbon monoxide, an invisible, odorless, but highly toxic gas. Inhalation of these gases may cause unconsciousness and death.

1. Check that the parking brake is engaged.
2. Depress the clutch pedal and put the gear lever in neutral.
3. Switch the ignition to position D.
4. Check that the warning indicator of the parking brake lights up.
5. Check that the oil pressure warning symbol in the master display is lit.
6. Check the operation of the fuel gauge and the coolant temperature gauge.
7. Check that the glow system warning lamp is off.
8. Without pressing the accelerator pedal down, turn the ignition to position S. If the engine does not start; the key must be released after 10 seconds. Then wait 10 seconds and try again.



### NOTE

The vehicle is equipped with start protection. The gear lever must be in neutral otherwise the start protection device will not allow the starter motor to activate.

If the engine is running, the engine speed may not be increased before the oil pressure warning symbol has extinguished.

# Driving



## NOTE

Depending on the coolant temperature measured by the electronic unit, it is possible that, in extremely cold conditions, the maximum engine speed is limited for a specific period of time.

In case of an optional engine speed control, one of various engine speeds can be selected with the right-hand steering column switch, if so desired.

Before driving away, check that the central "STOP" warning light is not illuminated.

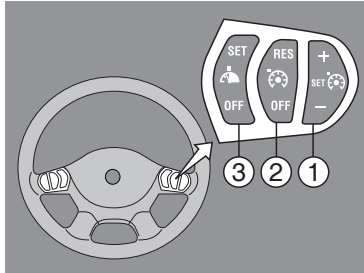

D001135-4

## ENGINE SPEED CONTROL

The minimum and maximum engine speeds that can be set are limited by a programmed value in the electronic unit. This value may be below the idling speed. In this case it will, however, not fall below idling speed.

The programmed engine speeds and conditions for activation or deactivation of the engine speed control can be modified by a Authorized Dealership on request.

### Activating the engine speed control

Press the 'SET+' or 'SET -' button (1) to immediately increase the engine speed to the set speed value. This value may have been or can be changed within specific limits by a Authorized Dealership to meet the customer's requirements.

Hold down the 'SET+' or 'SET-' button on the steering wheel switch (1) to gradually increase or decrease the engine speed.

# Driving



## NOTE

If the engine speed control is active, the engine brake is deactivated.



## NOTE

Depending on how the electronic unit is programmed, the accelerator pedal is active or not. When speed is increased via the accelerator pedal, the speed reduces to the set speed value once the accelerator pedal is released.

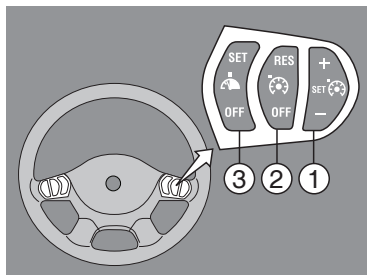

D001135-4

## Deactivating the engine speed control

Press the RES/OFF switch (2) to the 'OFF' position.

## Interruption of engine speed control

- When the vehicle brake is operated.
- When the parking brake is disengaged.
- When the clutch is operated.
- When the RES/OFF switch (2) is pressed to the 'OFF' position.
- When the engine speed control is active via the superstructure.



## WARNING

Check whether the stated conditions for deactivation of the engine speed control apply to the vehicle.

# Driving

## CRUISE CONTROL

Cruise control is a facility that can be used to have the vehicle maintain a constant vehicle speed. The desired driving speed is set, and the electronics maintain this speed. The driver can overrule the cruise control at any time by pushing the accelerator pedal.

The cruise control can be activated at a programmed minimum vehicle speed. This speed is 35 km/h as standard.

The programmed standard speed and the conditions for activation and deactivation of the cruise control can be modified by an authorized dealer upon request.



### WARNING

**Check whether the stated conditions for activation and deactivation of the cruise control apply to the vehicle.**

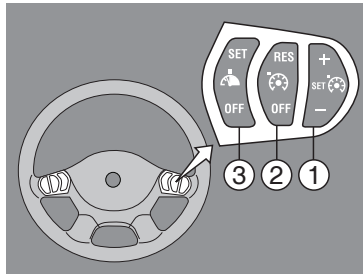

D001135-4

### Engaging Conditions

Cruise control can be activated when:

- The vehicle speed exceeds 36 km/h.
- no braking functions are active.
- there is no current engine management fault.
- the clutch is not operated.
- adjustable vehicle speed limiting is not active.
- vehicle speed limiting for special applications below 35 km/h is not active.



# Driving

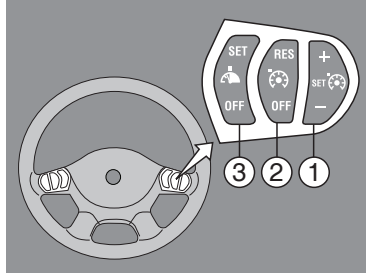

D001135-4

## Disengaging conditions

When the cruise control has been engaged, there are various conditions on which it disengages. Cruise control is deactivated when:

- vehicle speed is outside the programmed limit values.
- parking brake is operated.
- clutch is operated.
- foot brake is operated.
- position 'OFF' on the steering wheel switch (2) is operated or the adjustable vehicle speed limiting 'SET' is activated using the steering wheel switch (3).
- ABS/ASR system is activated.

## Engaging cruise control

Activate cruise control by toggling the steering wheel switch (1) once briefly to the 'SET+' position or to the 'SET-' position when the required control speed is reached. Cruise control can be activated when the vehicle speed is 36 km/h or more (or another value programmed by the Authorized Dealership).

## Modifying cruise control speed

When cruise control is activated, the speed can be increased by pressing 'SET+' or be decreased by pressing 'SET-' on the steering wheel switch (1). Briefly operate the switch to increase or decrease speed in small increments of 0.5 km/h.

Keep the switch down to gradually increase or decrease speed.

This limits the minimum and maximum adjustable speeds by values programmed in the electronic unit. These values can be modified within specific limits by an authorized Service dealer.

# Driving

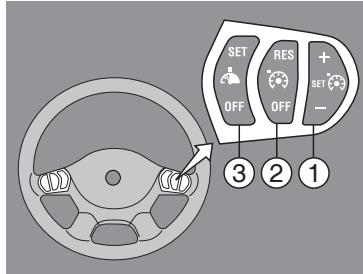

D001135-4

## **Accelerator pedal function during cruise control**

When cruise control is active, the vehicle speed can be increased above the control speed using the accelerator pedal. When the accelerator pedal is released, the vehicle speed will return to the last valid control speed.

## **Disengaging cruise control**

Press the 'OFF' switch (2) on the steering wheel to deactivate cruise control.

## **Re-engaging cruise control (Resume)**

When it has been deactivated, cruise control can be resumed, provided the above conditions are met, by pressing the 'RES' button (2) on the steering wheel. This re-engages cruise control at the last set speed. If the current vehicle speed is lower than this speed, cruise control accelerates to the programmed speed.

# Driving

---

## VEHICLE SPEED LIMITATION FOR SPECIAL APPLICATIONS

Speed limitation for special applications consists of a switch which is fitted on the vehicle superstructure. With this switch, the vehicle speed can be limited to a pre-programmed value. The programmed value can be modified by an authorized Service dealer on request.

## DRIVING STYLE

The following recommendations result in improved economy without adversely affecting the vehicle speed (i.e. slowing down). In other words: an efficient driving style. Anticipate traffic and other conditions; release the accelerator pedal in time (zero fuel consumption) and **do not** press down on the accelerator when it is **not necessary**



### NOTE

In the event of extreme acceleration to 30 to 40 km/h (19 to 25 mph) , and depending on the vehicle and engine type, the engine management system will intervene in the control of the engine to prevent excessive engine noise at high revs and low speeds.

# Driving

---

## STEERING

The steering gear is hydraulically assisted. As excessive pressure may damage the hydraulic pump, stop turning the steering wheel when the wheels are at full lock or are blocked by an obstacle. The steering gear may be damaged, if this is ignored.

## ABS BRAKES

The ABS system is an Anti-lock Braking System.

The ABS ensures good brake stability and good steering in a critical braking situation.

By preventing the wheels from locking, the steering characteristics of the vehicle are retained.

Bear in mind that when the prime mover is equipped with ABS but not the drawn vehicle, or vice versa, the directional stability and steering characteristics will not be as good as when both units are equipped with ABS.



### WARNING

**The ABS does not release the driver from his obligation to adapt his driving style to the traffic and road surface conditions.**

**The anti-lock protection cannot offset the results of driving too close to the vehicle in front or taking a bend at too high a speed.**

# Driving



## WARNING

**Do not adapt your driving style to the ABS system!**

**Above all, do not brake later and then harder.**

**This only causes unnecessary tire wear. It may also be hazardous for other road users.**



## NOTE

Occasionally, but not always, your braking distance will be shorter with ABS.



## WARNING

**If the yellow warning symbol "ABS truck fault" is activated, there is a fault in the ABS system of the prime mover.**

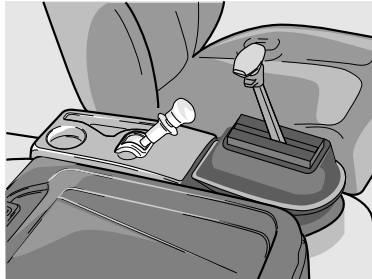

DD 00 587-1

## ABS warning symbol in master display

If the ABS warning symbol in the master display remains illuminated while driving, the ABS system is partly or completely deactivated and the brake system will work as if no ABS is present. The wheels may then lock upon braking.

## PARKING BRAKE AND SERVICE BRAKE



### **WARNING**

**Always apply the parking brake when parking the vehicle. Do not release the parking brake while the steering lock is still engaged. The vehicle cannot be steered if the steering lock is still engaged.**

The service brake is operated by the foot pedal. If the service brake fails to operate owing to insufficient air pressure, the parking brake can be used as an emergency brake. Moving the parking brake lever slowly backwards as far as the stop will gradually brake the vehicle or combination in a controlled manner. The parking brake is engaged by moving the parking lever back past the locking cam. On a vehicle with a drawn vehicle connection, the parking brake has a test position. See "Stopping". The parking brake is disengaged by lifting the locking ring up against the spring pressure and letting the parking brake lever move forwards.

# Driving

## ENGINE BRAKE

The engine brake is primarily intended for prolonged braking, for example when decelerating from high speed on a level road or when driving downhill. This reduces service brake wear.

The engine brake is activated by operating steering wheel switch (C).

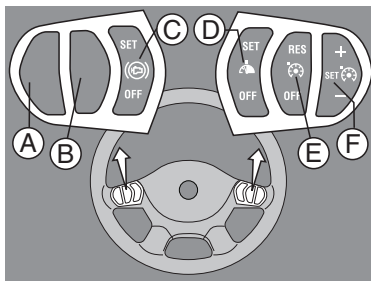

DO 01 190-3



### NOTE

- The engine cannot be switched off with the engine brake.
- To save the service brakes and to prevent the engine brake valve from becoming stuck, it is wise to regularly use the engine brake.

The braking effect decreases as the engine speed falls.

The most appropriate area of use for the engine brake is in the blue area of the revolution counter. The engine brake delivers the highest braking effect in this area.

When using the engine brake, adjust the gear selection so that the engine speed remains in the most favourable range. In case of an AS Tronic Lite gearbox, gear selection is automatic.

The engine brake is automatically switched off when:

- the engine speed drops below 1000 rpm.
- the ABS/ASR system has established a tendency for the wheels to lock.
- the accelerator pedal is depressed.
- the vehicle speed control or engine speed control has been activated.

# Driving



## **WARNING**

If the ABS/ASR control is activated, the engine brake will be switched off as long as the control is in operation. On vehicles where the ABS/ASR control fails to function or on vehicles not equipped with ABS/ASR, use of the engine brake may lead to the risk of skidding on slippery surfaces.

## **STOPPING**

### **Parking**

- Move the parking brake lever (from position A) backwards past the locking cam (position B). The parking brake is now engaged.
- When driving a tractor-trailer, check whether the parking brake lever can be moved even further backwards from position B against the pressure of the spring. Press in the parking brake lever and pull it further back (to position C). This is the test position, the drawn vehicle's brakes are not applied in this position. Check that the tractor-trailer remains in place.
- Let the parking brake spring back to position B.
- Place chocks in front of and behind the wheels.
- Angle the front wheels so that the vehicle will not move into the traffic stream if it is accidentally set in motion.



# Driving

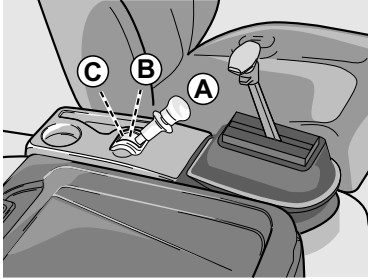

If the tractor-trailer does not remain in place in the test position, find a flatter place to park the vehicle. Always carry out this test if the vehicle is parked in unfavourable circumstances (gradient, slippery road surface, etc.). In this way, the tractor-trailer will remain safely parked, even if air leakage should make the drawn vehicle brakes ineffective.

## Switch off the engine.

Put the gear lever in neutral when the vehicle is stationary.

Before switching off the engine after a long trip or when the engine has been subjected to high loading, let it idle for at least 5 minutes. It is important to let the engine run for a while in order to prevent the coolant temperature becoming too high and to allow the turbocharger to cool down.

Switch the engine off by turning the ignition key to 0 position (rest position).

# Automatic Gearbox

# Automatic Gearbox

## ALLISON 2100 SERIES

### General

The automatic gearbox is fully electronically controlled. The automatic gearbox has 5 forward gears and 1 reverse gear.

The automatic gearbox is operated by a selector lever. The selector lever is located next to the driver's seat.

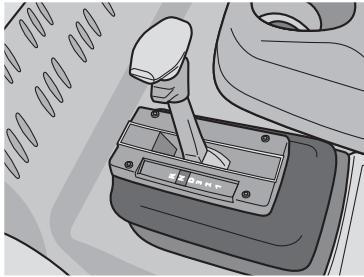

DO 00 789

### Shifting gears

The various gears are selected with the selector lever.

### Neutral position

No gears are activated in the "N" position. The vehicle is **not** locked in this position and can therefore roll.

Use the parking brake to lock the vehicle.

### Automatic forward drive

If the "D" position is selected, the vehicle will immediately begin to move (if the brake system is pressurized and the vehicle is not on the parking brake). It is therefore advisable to depress the brake pedal before selecting position "D". In this position the gearbox will automatically shift up and down in all forward gears. In the "1", "2" and "3" positions the gearbox shifts up to the selected gear. These positions are used to keep the engine within the proper speed range or to obtain the maximum engine brake performance.

### Reverse

If position "R" is chosen the vehicle will also be immediately set in motion. In this case, too, first depress the brake pedal and then select "R" position.

# Automatic Gearbox



## Faults

If the transmission fault warning symbol lights up in the master display, a fault has been detected in the gearbox.

Read the following recommendations first or consult an authorized dealer if necessary.

## Gearbox

The ECU will block the functions of the selector lever and ensure that the gearbox will select a "safe gear". It is important to drive the vehicle to a safe place as soon as possible and switch the ignition off. It will no longer be possible to shift the gearbox to neutral. The ECU will prevent this.

After approximately 30 seconds, try starting the engine again and engaging a gear. If the fault is one whereby the gearbox must in no circumstances be shifted, the ECU will no longer shift the gearbox. **Driving is therefore no longer possible!**

# Automatic Gearbox

## **Gearbox**

The ECU will block the functions of the selector and the gearbox will select a "safe gear" for the gearbox. It is important to drive the vehicle to a safe place as soon as possible and turn the contact off. It will no longer be possible to shift the gearbox to neutral. The ECU will prevent this.

After approximately 30 seconds, try starting the engine again and engaging a gear. If the fault is one whereby the gearbox must in no circumstances be shifted, the ECU will no longer shift the gearbox. **Driving is therefore no longer possible!**

If the fault is one whereby the gearbox may still be shifted, the warning in the main display will disappear. The ECU will have recorded the fault as an inactive fault. It is now possible to drive the vehicle again, though the fault will still need to be remedied.

In this situation, however, it is no longer possible to shift gears.

## **Gearbox oil temperature**

If the transmission fault warning symbol in the master display comes on during driving, this could be an indication that the gearbox oil has reached its maximum temperature.

In this situation, the ECU limits gearbox shifting to the first four gears.

It is important to drive to a safe place as soon as possible and let the engine idle in neutral at an increased idling speed.

As a result, the cooling system of the engine will try to cool the gearbox oil.

If after approximately two minutes the warning in the master display has not disappeared, the engine must be turned off and contact made with the nearest authorized Service dealer.

## Emergency Repairs

# Emergency Repairs

## TILTING THE CAB

### General



#### WARNING

Make sure that the filler caps of the cooling system, the hydraulic clutch and the windshield washer reservoir are tightened. Do not loosen the filler caps when the cab is tilted.



#### WARNING

Only tilt the cab when the engine has stopped.



#### WARNING

Make sure there is sufficient clearance around the cab.



#### WARNING

You can stop tilting the cab forward at any time by turning the valve to position ↓.



#### WARNING

If the vehicle has been involved in a collision, the cab must under no circumstances be tilted without due precautions. The internal mechanism of the lifting cylinder may have been damaged to such an extent that the cylinder is no longer locked by the internal stop washer. In that case there is a danger of the cab no longer being held back and falling forward to the ground. Have your authorized Service dealer check the tilting mechanism.

# Emergency Repairs



## WARNING

Make sure that there is no one in the cab. Also make sure there are no loose objects inside the cab; this includes objects in the refrigerator. Make sure there are no people immediately in front of the cab.



## WARNING

Never work under the cab if the cab has not been tilted fully forward.



## NOTE

If a cooler box/refrigerator has been fitted, it should be switched off and if necessary unplugged before tilting (depending on the type). The cooler box/refrigerator should remain switched off at least 30 minutes after the cab has been tilted back.

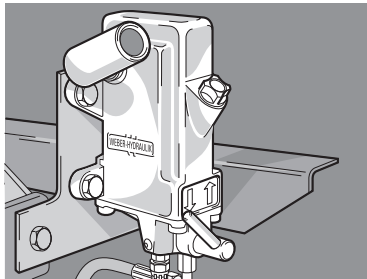

D0 00 623

The cab is tilted hydraulically using a hand pump. This pump is located at the co-driver's side, behind the cab. The pump has a cock which can be moved to two positions:

position  $\uparrow$  to tilt the cab forwards.

position  $\downarrow$  to tilt the cab backwards; this is also the driving position.



# Emergency Repairs

## Tilting forward

- Apply the parking brake.
- Put the gear lever in "neutral" position.
- Close the doors.
- Turn the lever fully to the right, against the spring pressure, until it is locked in position ↑↑; use the jack rod.
- Operate the pump so that the cab tilts forward. The cab locking mechanism automatically releases. As soon as the cab passes its natural point of balance, the force of gravity will gradually tilt the cab further forward without additional pumping.

## Tilting back

- Turn the lever to position ↓↓.
- Tilt the cab back by operating the pump with the jack rod. The last part of tilting-back is effected by the cab's own weight. When the catch engages, the cab is automatically locked.
- Leave the lever in position ↓↓.
- Push the gear lever in 1st gear to lock the gearbox control.
- Put the gear lever in neutral.

## Checking the cab locking

When the cab is back in its normal position, the cab lock warning lamp in the master display should be extinguished.

# Emergency Repairs

## REPLACING THE POLY-V BELT

### Important

Always fit the same type of poly-V-belt as the one being replaced.

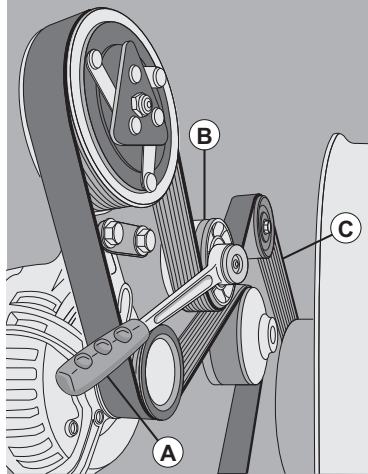

DO 00 633-1

1. Disconnect the earth lead from the battery.
2. Place a ratchet (A) with a 3/8" socket in the arm of the automatic belt tensioner (B).
3. Slacken the poly-V-belt (C) (see arrow in illustration), so that it can be removed from the pulleys.
4. Carefully allow the automatic belt tensioner to spring back to the stop.
5. Push the poly-V-belt between the fan and the wind tunnel collar and remove the poly-V-belt.
6. Check all pulleys over which the poly-V-belt runs for dirt, rust and damage.
7. Fit a new poly-V-belt between the fan and wind tunnel collar. Place the poly-V-belt over as many pulleys as possible.
8. Tension the automatic belt tensioner and place the poly-V-belt over the remaining pulleys. Carefully allow the automatic belt tensioner to spring back against the new poly-V-belt.
9. Check that the poly-V-belt is in all pulley grooves.
10. Connect the earth lead to the battery.

# Emergency Repairs

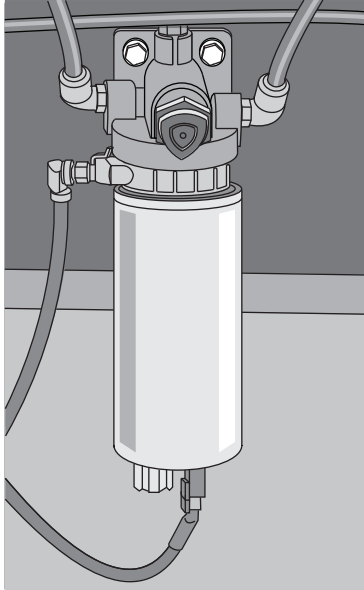

D0 02 002

## REPLACING THE FUEL FINE FILTER



### WARNING

When removing the fuel fine filter, a quantity of fuel will escape. Collect the fuel and avoid the risk of fire.

Dirt in the fuel system can lead to significant damage to the fuel system.

Diesel fuel is toxic and can therefore have a damaging effect on your health. Any direct or indirect physical contact should therefore be avoided.

In the event of contact with the skin: remove with paper or a cloth, wash with soap and water. If irritation persists, consult a doctor.

If swallowed: do NOT induce vomiting. Rinse the mouth, drink two glasses of water and see a doctor.

In the event of inhalation: get some fresh air and rest.

### Removing the fuel filter

1. Place a receptacle under the filter.
2. Remove the filter by turning it anti-clockwise.



### NOTE

The fuel fine filter is a disposable filter and, therefore, may not be cleaned and reused.

# Emergency Repairs

## Fitting the fuel filter

1. Lightly lubricate the sealing ring (see arrow in illustration) with clean engine oil (not diesel fuel).
2. Fit the filter unfilled until the sealing ring abuts and manually rotate it a  $\frac{1}{2}$  to  $\frac{3}{4}$  turn further.
3. Bleed the fuel system. See "BLEEDING THE FUEL SYSTEM".
4. Start the engine and check for leaks. If necessary, retighten the filter by hand.

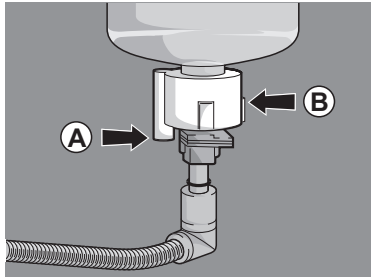

## DRAINING THE WATER SEPARATOR



### WARNING

**When draining the water separator, an amount of fuel will escape. Collect the fuel and avoid the risk of fire.**

**Water in the fuel system may lead to significant damage.**

1. Place a container beneath the water separator.
2. Remove the connector.
3. Unscrew the ring-shaped drain cock (B) on the bottom of the water separator in anti-clockwise direction.
4. Drain the filter until pure diesel fuel comes out of the drain cock (A).
5. Turn the drain cock (B) if it abuts, another  $\frac{1}{8}$  -  $\frac{1}{4}$  turn.
6. Check the drain cock (B) for leakage.
7. To prevent pollution, the drained water/diesel fuel mixture should be passed to the relevant authorities for reprocessing.

# Emergency Repairs

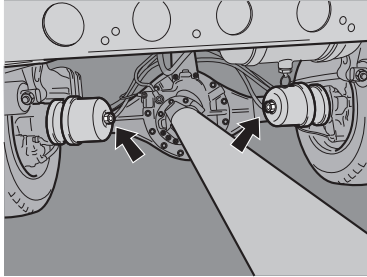

D0 00 606

## RELEASING THE PARKING BRAKE



### WARNING

Never release the parking brake on an incline.

1. Place wheel chocks in front of and behind the wheels.
2. Turn the release bolt counter-clockwise as far as the stop using a ring spanner.
3. This operation should be carried out for each spring brake cylinder.
4. Bring the parking brake back in operating order as soon as possible by turning the bolts clockwise as far as possible and tightening them to a torque of 70 Nm (51.6 lb-ft).

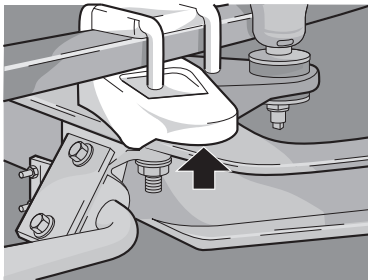

D0 00 626

## JACKING UP THE FRONT AXLE

When jacking up the front axle, the jack must be positioned under the jacking point near the shock absorber.



### WARNING

Always use stands to support the chassis when carrying out repairs or service under a vehicle which is resting on a jack.

# Emergency Repairs

## JACKING UP THE REAR AXLE

When jacking up the rear axle, the jack should always be positioned under the jacking point at the bottom of the spring bracket.

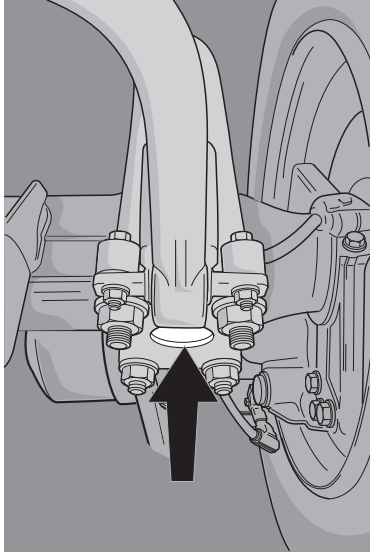

DO 00 719



### WARNING

**Always use stands to support the chassis when carrying out repairs or service under a vehicle which is resting on a jack.**

**To prevent deformation of the axle housing, the jack must under no circumstances be located directly under the axle housing or the differential casing.**

# Emergency Repairs

## CHANGING THE WHEEL



### NOTE

After changing a wheel/tire, the difference between the diameters of the various tires on the vehicle may have become too large (for example, as a result of differences in tread depth and/or tire pressure).



### WARNING

**The ABS system cannot cope with too great a difference in tire diameter and the system will automatically be disengaged. Consequently, the ABS warning symbol will be shown in the master display.**

Depending on the tire types on the front and rear axle, this phenomenon may already with a worn tire that is underinflated by 2 bar. So first check the tire pressure if the warning indicator is on after a tire has been replaced.



### WARNING

**Hence, there will be no ABS control under extreme conditions!**

This is the reason why the maximum permitted difference in tire diameter for new tires is 14%.

(This may occur when different tire sizes are fitted on the front or rear axles.)



### WARNING

**When removing a wheel with a cracked or damaged wheel rim, always deflate the tire (remove the tire valve) in view of possible tensions in the wheel rim.**

# Emergency Repairs

## General

- Only use the original tire wheel rims specified for the vehicle concerned.
- Make sure that tires of the same type are fitted on both sides of the axle.
- Insufficient cleaning of the mating surfaces and/or uneven tightening of the wheel nuts may cause vibrations during driving or braking.



### NOTE

If a wheel stud is renewed, the other wheel studs on the relevant wheel must also be renewed.

## Removing the wheel

1. Chock the wheels to prevent the vehicle moving off.
2. Clean the screw thread of the wheel studs using a wire brush.
3. Oil the wheel studs sparingly.
4. Unscrew the wheel nuts.
5. Fit a jack under the jacking point at the wheel to be replaced.
6. Jack up the vehicle and place a support under the axle.
7. Remove the wheel nuts and take the wheel off the hub.

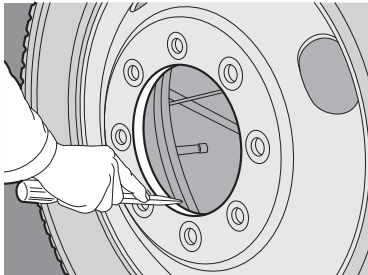

D000495

## Installing the wheel

1. Clean the fitting edge of the wheel hub by scraping off dirt and corrosion with a scraper.



# Emergency Repairs

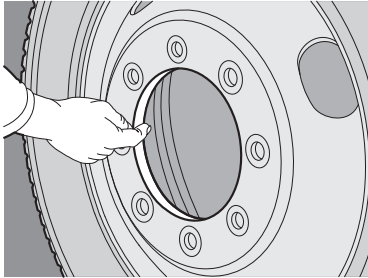

D000496

2. Apply a **thin** layer of grease to the fitting edge of the wheel hub.
3. Also apply a **thin** layer of grease to the fitting edge of the wheel rim. This grease layer should prevent the wheel rim and the wheel hub from becoming "rust-bound".
4. Check whether the contact surfaces of the wheel rim and the drum brake are clean. Clean if necessary.

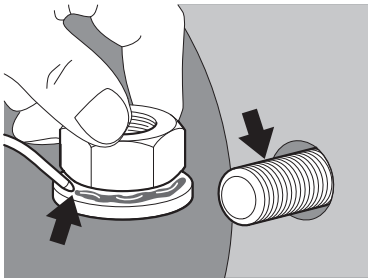

D000520

5. Clean the wheel nuts and then apply a drop of oil between the thrust washer and the nut.
6. Also apply a drop of oil to the first turn of the wheel-stud screw threads.

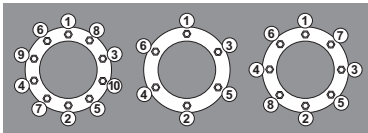

DS 00 015

7. Fit the wheel nuts and tighten them evenly according to the sequence in the illustration.

For the specified tightening torque, see "TECHNICAL DATA".

# Emergency Repairs

---



## **NOTE**

Wheel nuts should always be tightened and retightened in cold condition. However, tightening wheel studs in extreme cold should be avoided.

8. Check the tire pressure.
9. Retorque the wheel nuts after 100 km (62 miles).

If new wheel studs are fitted, they need additional retorquing after 500 km (31 miles).



## **NOTE**

When a wheel had to be replaced, have the wheel nuts torqued to the correct tightening torque by a dealer.

# Emergency Repairs

## TIRE INFLATING CONNECTION

Next to the brake system air dryer to the left rear of the cab there is a tire inflating connection.

1. Remove the rubber protective cap from the tire inflating connection.
2. Connect the tire inflating hose.
3. Pump up the tire. Inflate the tires while the engine is running and with maximum pressure in the air reservoirs.
4. Refit the protective rubber cap to the tire inflating connection after the tire has been inflated and store the hose.

Check as soon as possible that the tires have the correct pressure using a pressure gauge. See the tire pressure table under "TECHNICAL DATA".



### NOTE

The entire air pressure system of the vehicle can be filled with air from an outside source using the tire inflating connection. When doing this, check that the system pressure is correct using the air pressure gauge.

# Emergency Repairs

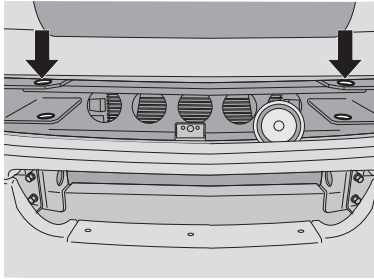

DD 00 723

## TOWING

It is possible to install a towing eye behind the grille.

Always use a towing bar when towing. Departure from this rule is only allowed in emergencies.

When towing, the fault message "Engine management fault" may appear in the master display when the ignition is turned on.



### NOTE

The maximum permissible vehicle speed, weight and distance vary per country.

Tractors may be fitted with a small towing hook at the rear end of the chassis. This towing hook must only be used for light shunting work.



### WARNING

**Do not tow the vehicle when fully loaded or with a drawn vehicle attached.**

### Being towed by another vehicle



**When the engine is not running, there is no power steering and no air is supplied to the braking system.**

**If the service brake is applied or in the case of air leakage, the parking brake might be applied.**

# Emergency Repairs

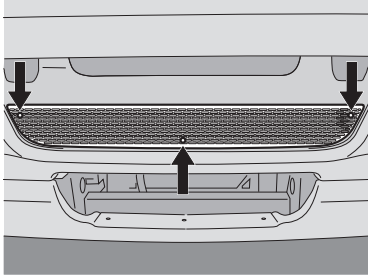

D0 00 722



## WARNING

The towed vehicle can be located asymmetrically (left or right) behind the tractor. Towing may not take place at an angle larger than 20° with the vehicle centerline.

- To clear the towing eyes, the black grid must be removed from the lower grille by turning the attachment screws a quarter turn.
- Always fix the tow rod with its original attachment pin (part of the vehicle tool kit) in the towing eyes.
- Turn the ignition key so that the steering wheel is released (unless the vehicle is in a hoist, see below).
- To prevent damage to the gearbox, the propeller shaft must **always** be disconnected from the differential.
- If there is insufficient pressure in the air reservoirs, release the parking brake. See "Releasing the parking brake".

### If the differential is damaged:

- Hoist the vehicle at the rear and **lock the steering wheel in the straight-ahead position**.

### Tow starting

If the vehicle has to be towed to start the engine, the ignition key must first be turned clockwise to position D of the starter/ignition switch (ignition on).

### Long-distance towing

If the vehicle is to be moved over a larger distance, this must be done by a recovery vehicle that lifts the vehicle to be towed under its front axle.

# Emergency Repairs

## REPLACING BULBS

- Do not touch the glass of the halogen lamps with bare fingers. If necessary, this glass can be cleaned with a cloth, which has been dampened with industrial alcohol (methylated spirits).
- When fitting a new bulb, make sure that the lugs on the bulb holder engage in the slots of the reflector.

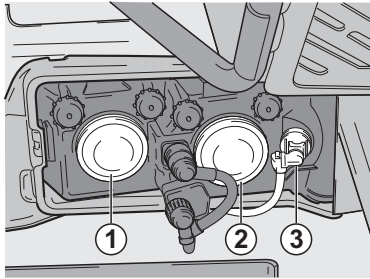

D0 00 594

### Dipped beam

1. Tilt the cab forwards.
2. Detach the rubber cover (2) from the rear of the headlamp unit.
3. Detach the spring clamp and pull the bulb away from the reflector.
4. Detach the double plug from the rear of the bulb.

### Parking light

1. Tilt the cab forwards.
2. Detach the rubber cover (2) from the rear of the headlamp unit.
3. Pull the holder of the parking light from the headlamp unit.
4. Pull the bulb out of the bulb holder.

### Main beam

1. Tilt the cab forwards.
2. Detach the rubber cover (1) from the rear of the headlamp unit.
3. Detach the spring clamp and pull the bulb away from the reflector.
4. Detach the spring clamp and pull the bulb away from the reflector.

# Emergency Repairs

## Direction indicator

1. Tilt the cab forwards.
2. Detach the plug from the rear of the bulb holder (3).
3. Screw the bulb holder anti-clockwise out of the headlamp unit.
4. Pull the bulb carefully out of the bulb holder.

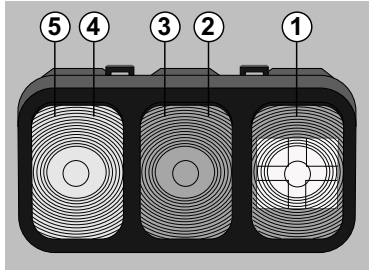

D0 02 016

## Rear lights

1. Unscrew the four Philips screws and remove the lens cap.
  1. Fog light
  2. Reversing light
  3. Rear light
  4. Stop light
  5. Direction indicator

## Direction indicators

1. Detach the plug on the inside bumperend cap/step moulding.
2. Remove the two screws and detach the lamp unit of the direction indicator.
3. Unscrew the bulb holder anti-clockwise out of the indicator lamp unit.
4. Pull the bulb carefully out of the bulb holder.

# Emergency Repairs

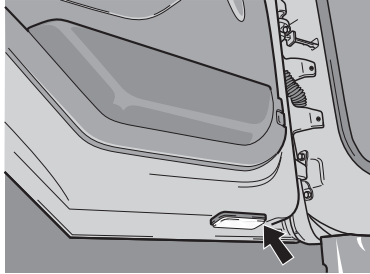

D0 00 590

## Stepwell lighting

1. Remove the stepwell lighting housing from the bottom of the door by inserting a screwdriver in the notch.
2. If necessary, remove the plug.
3. Unscrew the bulb holder anti-clockwise out of the stepwell lighting housing.
4. Pull the bulb carefully out of the bulb holder.

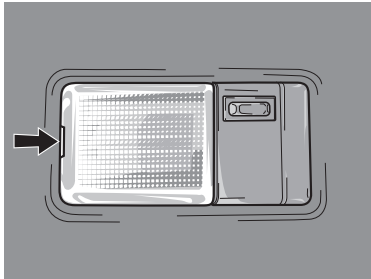

D0 00 571

## Roof light

The transparent covers of the roof lights have a slot allowing the lens to be tilted out of the housing using a screwdriver.

1. Remove the transparent cover of the roof light carefully from the roof upholstery.
2. Pull the bulb carefully out of the bulb holder.



# Emergency Repairs

## FUSES AND RELAYS



### WARNING

To prevent overload and the risk of fire you must **NEVER** replace a burnt-out fuse with a fuse with a higher rating than specified. If a specific fuse repeatedly blows, this means there is a fault in the circuit, which **MUST** be inspected and remedied.

**NEVER** replace or remove a fuse if:

- the contact is on.
- the engine is running.
- a consumer is switched on.

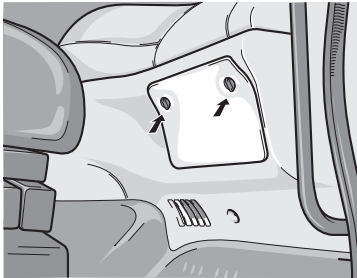

DO 00 617

The fuses are behind a cover in the dashboard on the co-driver's side. Attached to the inside of the cover is a sticker with an overview of the fuses. For replacing fuses there is a special fuse clamp on the fuse board. Each fuse is color-coded to show the rating:

Orange	5 A
Red	10 A
Blue	15 A
Yellow	20 A
Transparent	25 A
Green	30 A

# Emergency Repairs

---

## **Fuses**

E004	Fuse, driver's side dipped beam
E005	Fuse, co-driver's side dipped beam
E006	Fuse, driver's side main beam
E009	Fuse, rear fog lights
E013	Fuse, stop lights
E016	Fuse, reversing lights and cross-axle lock control
E018	Fuse, G.O reverse lamp
E019	Fuse, horn
E023	Fuse, tachograph timer
E025	Fuse, wiper wash
E026	Fuse, cigar lighter/door switches/electronic unit, converter 24/12 V with power supply for radio memory
E027	Fuse, converter 24/12
E028	Fuse, interior lighting/central door locking
E031	Fuse, heater and air conditioner
E035	Fuse, ECU engine ignition
E039	Fuse, seat heating
E044	Fuse, mirror heating/electrical mirror adjustment/electrical window operation/sun roof
E051	(unused)
E052	Fuse, body light

# Emergency Repairs

---

## Fuses

E053	Fuse, diagnostic connector/ECAS
E058	(unused)
E062	Fuse, ECAS remote
E091	Fuse, Mechanical clutch/air Orer
E108	Fuse, VIC
E114	Fuse, cab heater
E142	Fuse, accessories unswitched power
E143	Fuse, option / various/ ABS
E144	Fuse, automatic gearbox AGC
E145	Fuse, gear box
E153	(unused)
E156	Fuse, accessories
E160	Fuse, engine ECU
E163	(unused)
E164	Fuse, fuel heater
E165	Fuse, fuel heater FPH-E, switched power
E190	Fuse, ABS-E / ASR
E198	Fuse, central door lock
E277	Fuse, VIC
E279	(unused)
E280	Fuse, VIC

# Emergency Repairs

---

## Fuses

E282	(unused)
E283	Fuse, side lights
E284	Width marker light
E285	Fuse, fog lights switch
E286	(unused)
E290	Fuse, customer adaptation cab
E297	Fuse, airbag and seat belt tensioner system
E299	(unused)
E310	Fuse, instrument panel, DIP-4
E330	(unused)
E349	(unused)
E350	Fuse, remote bat ISO
E354	(unused)
E357	Fuse, dosing unit
E390	Fuse, body builder module
E409	Fuse, dosing module
E434	Fuse, Nox unit

# Emergency Repairs

---

## Technical Data and Identification

# Technical Data and Identification

## ENGINE

### Type

Model: KW: K270, K370 or PB:210, 220, PX6-2010

### Engine

Engine type	B ENGINE
Model	EPA 10, water-cooled, four-stroke diesel engine with electronically controlled fuel injection system, 4 valves per cylinder and turbo-intercooling.
Number of cylinders	6 In Line
Bore x stroke	107 x 124 mm
Total capacity	6.7 litres
Capacity of lubrication system, including filter and oil cooler	liters TBD
Sump capacity, maximum level	liters 18L (w/OP9517 Option)
Sump capacity, minimum level	liters 16L (w/OP9517 Option)
Capacity of cooling system, including heater	liters TBD

### Output and torque

Type	Maximum output P (kW/hp)	Engine speed at max. output $n_p$ (rpm)	Maximum torque M (Nm)/(lb ft)	Engine speed at max. torque $n_m$ (rpm)
PX-6 220hp	164/220	1600	705 / 520	215-2600
PX-6 240hp	179/240	1600	759.2 / 560	235-2600
PX-6 250hp	186/250	1600	894.8 / 660	245-2600

# Technical Data and Identification

## ELECTRICAL SYSTEM

Voltage	12/24 V
Alternator	160 A / 14 V
Batteries	700 / 1000 CCA
Starter motor	3.3 Kw / 12 V

## Bulbs

Dipped beam Left/right	12V/55W
Main beam Left/right	12V/55W
Auxiliary high beam	12V/55W
Fog lights	12V/55W
Tail light Left/right	12V/45W
Cab interior lighting	24V/15W
Stepwell lighting	24V/5W
Marker lights	12V/5W
Side repeater lights	12V/21W
Roof lights	24V/5W



# Technical Data and Identification

## WHEELS

Whenever the wheel nuts have been slackened or removed, they must be retorqued with a torque wrench after 100 km (62 miles).



### WARNING

**If a wheel stud is renewed, the other wheel studs on the relevant wheel must also be renewed. If new wheel studs are fitted, the nuts must be retorqued after 500 km (310 miles).**

## Wheel nut tightening torques

### Model K270 / K370, 210 / 220

Version with 8 M20 wheel nuts	485 Nm (357.7 lb ft)
Version with 10 M22 wheel nuts	644 Nm (475 lb ft)

# Technical Data and Identification

## TIRE PRESSURE TABLE (METRIC)

Recommended pressure (bar) at various loads (kg) E= single fitting D= twin fitting																						
Tires size		2000	2500	3000	3500	4000	4500	5000	5500	6000	6500	7000	7500	8000	8500	9000	10000	11000	12000	13000	Max. axle load (kg)	Pressure at maximum axle load
245/70 R19.5	D							4.2	4.7	5.2	5.7	6.2	6.7	7.2							7248	7.5
285/70 R19.5	D									4.6	5.2	5.6	6.0	6.5	7.3						9513	7

## TIRE PRESSURE TABLE (IMPERIAL)

Recommended pressure (psi) at various loads (lb) E= single fitting D= twin fitting																						
Tires size		4400	5500	6600	7700	8800	9900	11000	12100	13200	14300	15400	16500	17600	18700	19800	22000	24200	24600	28600	Max. axle load (lb)	Pressure at maximum axle load
245/70 R19.5	D							60.9	68.15	75.4	82.65	89.9	97.15	104.4							9592	120.35
285/70 R19.5	D									66.7	75.4	81.2	87	94.25	105.85						12320	101.5

# Technical Data and Identification

## Checking the tire pressures

Tire pressures depend on axle load and tire size.

### Tire pressure table\*

- The tire pressures shown in the table apply to cold tires.
- Unnecessary tire wear is frequently caused by vehicle operation with tire pressures which do not match the axle load.
- When twin wheels are fitted:
  - Both tires must be inflated to the same pressure;
  - The tread depth must be practically the same on both tires.

\* The axle loads and corresponding tire pressures shown in the table apply to normal operating conditions. For all other cases, refer to the specifications of the tire manufacturer.

## LUBRICANT-, ENGINE COOLANT- AND FUEL SPECIFICATIONS

**To comply with the warranty terms and to guarantee the durability of the manufacturers products, it is essential that the correct lubricants, engine coolant and fuel are used and that the oil change intervals are adhered to.**

**Additives to lubricants, engine coolant and fuel - of whatever type - must not be used except in those circumstances prescribed by the manufacturer.**

**Always follow the safety instructions below and the instructions that are supplied with the product.**

**Use Ultra Low Sulfur Diesel Fuel only. Failure to do so may cause exhaust equipment damage.**

# Technical Data and Identification

Ask your lubricant and fuel suppliers whether their products comply with specifications.

The manufacturer is not liable for damage or problems in the following instances:

- If oil has been used of a lower grade than specified.
- If oil has been used of a different viscosity than specified.
- If the specified oil change interval has been exceeded.
- If fuel, lubricants or coolants have been used which do not meet the requirements specified.



## **WARNING**

**Avoid physical contact with:**

- lubricants
- coolants
- Fuel
- battery acid

**In the event of skin contact: remove substance with paper or cloth, wash with soap and water.**

**Consult a doctor in the event of persistent irritation.**

**In the event of contact with the eyes: remove substance with soft cloth and rinse with water.**

**Consult a doctor in the event of persistent irritation.**

**If any is swallowed: DO NOT induce vomiting. Rinse mouth, drink two glasses of water and consult a doctor.**

**In the event of inhalation: get some fresh air and rest.**

# Technical Data and Identification

---

## **Battery acid:**

**In the event of skin contact: rinse the skin profusely with plenty of water.**

**Consult a doctor in the event of persistent redness or pain. Remove polluted clothing and rinse in water.**

**In the event of contact with the eyes: rinse with plenty of water for at least 15 minutes and see a doctor.**

**If any is swallowed: do NOT induce vomiting. Rinse the mouth, drink two glasses of water and see a doctor.**

**In the event of inhalation: get some fresh air, rest and consult a doctor.**

## **ENGINE OIL**

**Specification lists refer to international standards, such as ACEA and API. Viscosity is also subject to specific requirements.**

Additional information:  
PX-6 2010:Synthetic oil

Explanation of overview:  
**V** = may be used

# Technical Data and Identification

## COOLANTS



### WARNING

Coolant is a toxic fluid. Protect skin and eyes. In case of accidental contact with skin and/or eyes, see "Lubricant, engine coolant and fuel specifications".

Coolant is harmful to the environment; after use, it should be processed as industrial chemical waste.

The cooling system should preferably be filled with a ready-mixed coolant containing antifreeze and corrosion inhibiting additives.

The coolant present in the cooling system from the factory consists of an ethylene glycol base: Climatech

### Coolant identification

A sticker behind the grille states the information on the coolant used.

<p><b>⚠ CAUTION / ⚠ CAUTION</b> Extended Life Coolant / Antifreeze</p> <ul style="list-style-type: none"><li>- Factory Filled with Extended Life Coolant Antifreeze</li><li>- Use only Extended Life Coolants meeting Caterpillar CAT EC-1 or equivalent specifications</li><li>- Do Not mix with conventional coolants or any Supplemental Coolant Additives (SCAs)</li><li>- Use only Blank or Non-Chemical Filters if vehicle is equipped with a coolant filter</li><li>- Refer to Operator's or service manual for instructions to ensure proper level and mixture</li><li>- Failure to maintain proper coolant level and mixture can cause engine damage</li></ul>
<p><b>Fluide de refroidissement de grande longévité / Antigél</b></p> <ul style="list-style-type: none"><li>- Système rempli en usine avec antigél de grande longévité.</li><li>- UTILISER SEULEMENT l'antigél de grande longévité rencontrant les spécifications Caterpillar CAT EC-1 ou équivalent.</li><li>- NE PAS mélanger avec liquide de refroidissement conventionnel ou tout additif SCA.</li><li>- Si le véhicule est équipé d'un filtre à antigél, utiliser seulement un filtre neuf et non chimique.</li><li>- Se référer au manuel d'opérateur ou de maintenance pour les instructions relatives au niveau de remplissage et composition du mélange.</li><li>- Maintenir un niveau de fluide inadéquat ou un mélange non approprié peut causer des dommages au moteur.</li></ul>

DO 02 018

# Technical Data and Identification

## Coolant according to specification 74002

The below table lists the current suppliers that meet specification 74002. It is not allowed to fill the cooling system with another product than the one specified in this overview.

<b>Brand name</b>	<b>Supplier</b>
Long Life Coolant	N.V.
Havoline XLC/Havoline Extended Life Antifreeze Coolant	ChevronTexaco
Caltex Extended Life Coolant	Caltex
Total Organifreeze	Total
Maxigel Plus/Ultracooling Plus	Renault Truck Oils
Bevercool Organic	Beverol
BP Procool	BP
Castrol Antifreeze SF Premix	Castrol
Inugel Optimal/Inugel Optimal Ultra	Motul
Yacco LR Organique	Yacco
Valvoline Antifreeze Extreme	Valvoline
Petrol Antifriz Koncentrat	Petrol
Orvema Protex Long Life/Coolmix LL	Orvema
SB-G12	Sotragel

# Technical Data and Identification

---

## **STEERING GEAR**

Hydraulic power steering

ATF DEXRON III with valid approval number

## **CAB TILTING MECHANISM**

Cab tilting pump

The following may be used:

Oil must meet MIL-H-5606C

ESSO Univis J13

FINA Hydran B5219B

TEXACO Aircraft Hydraulic Oil 5606G

TOTAL Aerohydraulic 520



# Technical Data and Identification

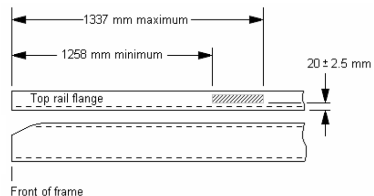

D0 02 015

## CHASSIS NUMBER

The chassis number is the last 6 digits of the VIN number. It is stamped on the right chassis side member close to the front axle.

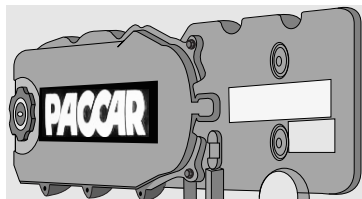

D0 00 597-1

## ENGINE NUMBER

The engine number is located on the data plate located on the top cover of the engine.

 Cummins Cummins Engine Co. Inc. Columbus, Indiana 61801-0001	C.I.D./L	PSL	Engine Model No.
	Family		Gen. spec.
• Weights and capacities are approximate. A number of factors can affect actual capacity and performance. Maximum values for this model and application.	Year (to 9999)	Stk.	Engine Model
	Year (last used)	Stk.	Plant code or plant SP
Serial No.	Plant code	Plant code	Plant code
Made in: China/ Mexico / Cummins Engine Co. Ltd.	Plant code	Plant code	Plant code

D0 00 599

# Technical Data and Identification

## PAINT IDENTIFICATION PLATE

The paint identification plate is attached to the bulkhead behind the front panel.

## VEHICLE IDENTIFICATION LABEL

The vehicle identification plate is located on the door jamb. Each vehicle uses a Vehicle Identification Number (VIN) that contains the model year designation of your vehicle. The practice is in compliance with 49 CFR 565, Code of Federal Regulations. The VIN contains 17 digits. The 10th digit is the code for the model year of your vehicle. The example VIN below from a 1999 model shows how this code works:

EXAMPLE VIN: 1XP 9D2X9 6 X D 345678

Model Year \_\_\_\_\_ Serial Number

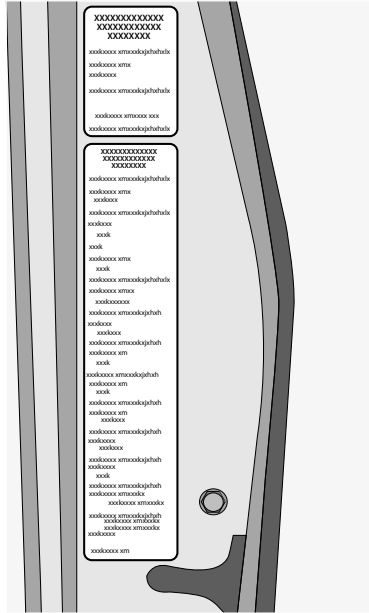

D0 00 667-1



## Consumer Information

# Consumer Information

## FEDERAL SAFETY STANDARD CERTIFICATION LABEL

The National Highway Traffic Safety Administration regulations require a label certifying compliance with Federal Safety Standards, for United States and U.S. Territories, be affixed to each motor vehicle and prescribe where such label may be located. This certification label, which indicates the date of manufacture and other pertinent information, is located on the left hand cab door post

MANUFACTURED BY		TIRE SIZE		RIM SIZE		PSI COLD	THIS VEHICLE CONFORMS TO ALL APPLICABLE FEDERAL MOTOR VEHICLE SAFETY STANDARDS IN EFFECT ON THE DATE OF MANUFACTURE SHOWN ABOVE
PETERBILT MOTORS CO. FR. DIV.	DATE MFD	DATE MFD	DATE MFD	DATE MFD	DATE MFD	VIN	
DIVISION OF FACCOR Inc. 2ND DIV.	GVMR	4TH DIV.				TYPE VEH TRUCK ISector	
						LABEL NO. 22-50199 REV. 8	

## How To Order Parts

When you need replacement parts for your Kenworth / Peterbilt vehicles, contact your nearest authorized Kenworth / Peterbilt dealer, who may be located from the "Kenworth / Peterbilt Authorized U.S. and Canadian Dealers" listing (Cat. No. 5212).

When you order, it is IMPORTANT that you have the following information ready:

- Your name and address.
- Serial number of the truck.
- The name of the part you need.
- The name and number of the component for which the part is required.
- The quantity of parts you need.
- How you want your order shipped.

# Consumer Information

---

## **NHTSA Consumer Information**

The National Highway Traffic Safety Administration requires that the following information be included in the owner's manual of motor vehicles manufactured after September 1, 1990:

If you believe that your vehicle has a defect which could cause a crash or could cause injury or death, you should immediately inform the National Highway Traffic Safety Administration (NHTSA) in addition to notifying KW/PB Motors Company.

If NHTSA receives similar complaints, it may open an investigation, and if it finds that a safety defect exists in a group of vehicles, it may order a recall and remedy campaign. However, NHTSA cannot get involved in individual problems between you, your dealer, and KW/PB Motors Company.

To contact NHTSA, you may either call the Auto Safety Hotline toll-free at 1-800-327-4236 (TTY 1-800-424-9153), email to [nhtsa.webmaster@dot.gov](mailto:nhtsa.webmaster@dot.gov) or write to: Office of Defects Investigations, CRD NVS-216, 1200 New Jersey Ave SE, Washington, D.C. 20590. You can also get other information about auto safety from the Hotline.

For additional road safety information, please visit the NHTSA website at <http://www.safercar.gov>

# Consumer Information

## Canadian Consumer Information

Canadian customers who wish to report a safety-related defect to Transport Canada, Defect Investigations and Recalls, may telephone the toll free hotline 1-800-333-0510, or contact Transport Canada by mail at

Transport Canada, ASFAD

Place de Ville Tower C

330 Sparks Street

Ottawa ON K1A 0N5.

For additional road safety information, please visit the Road Safety website at <http://www.tc.gc.ca/roadsafety/menu.htm>

## Environmental Protection



### Warning

**Diesel engine exhaust and some of its constituents are known to the State of California to cause cancer, birth defects, and other reproductive harm. Other chemicals in this vehicle are also known to the State of California to cause cancer, birth defects or other reproductive harm. This warning requirement is mandated by California law (Proposition 65) and does not result from any change in the manner in which KW/PB trucks are manufactured.**

Some of the ingredients in engine oil, hydraulic oil, transmission and axle oil, engine coolant, diesel fuel, air conditioning refrigerant (R12, R134a, and PAG oil), batteries, etc., may contaminate the environment if spilled or not disposed of properly. Contact your local government agency for information concerning proper disposal.

# Consumer Information

---

State of California

California Vehicle Code, Section 9951 - Disclosure of Recording Device

Your vehicle may be equipped with one or more recording devices commonly referred to as “event data recorders (EDR)” or “sensing and diagnostic modules (SDM)”. If you are involved in an accident, the device(s) may have the ability to record vehicle data that occurred just prior to and/or during the accident.

For additional information on your rights associated with the use of this data, contact the California Department of Motor Vehicles - Licensing Operations Division

or

[http://www.dmv.ca.gov/pubs/vctop/d03\\_6/vc9951.htm](http://www.dmv.ca.gov/pubs/vctop/d03_6/vc9951.htm)

## **California Proposition 65 Warning**

Diesel engine exhaust and some of its constituents are known to the State of California to cause cancer, birth defects, and other reproductive harm.

Other chemicals in this vehicle are also known to the State of California to cause cancer, birth defects or other reproductive harm.

Battery posts, terminals, and related accessories contain lead and lead compounds, chemicals known to the State of California to cause cancer and reproductive harm. Wash hands after handling.





---

## Alphabetical index

<b>A</b>			
Adjustable steering column.....	68	Draining the water separator .....	101, 139
Air conditioning switch .....	57	Driving style .....	122
Air filter indicator .....	97	<b>E</b>	
Air pressure gauge, circuits 1 and 2 .....	40	Electrical mirror adjustment .....	35
Antifreeze .....	165	Electrical system.....	159
<b>B</b>		Electrically operated windows .....	34
Batteries.....	102	Engine .....	158
Bleeding the fuel system.....	139	Engine brake .....	126
Brake system air drier .....	100	Engine number .....	168
Bulbs .....	159	Engine oil.....	164
<b>C</b>		Engine oil level .....	93
Cab maintenance.....	103	Engine Speed Control .....	117
Cab tilting mechanism.....	167	Environmental Protection .....	174
Center console.....	62	<b>F</b>	
Central door locking.....	34	Fan opening selector switch .....	61
Changing the wheel .....	142	Fan speed selector switch .....	60
Chassis number .....	168	Federal Safety Standard Certification Label.....	172
Cleaning.....	104	Fluid level in screen washer reservoir .....	97
Consumer Information .....	173	Fuses and relays .....	152
Control panel.....	51	<b>G</b>	
Coolant.....	94	Glow system .....	115
Coolant temperature gauge .....	40	<b>H</b>	
Coolants.....	165	Hazard warning lights .....	62
Cooling system .....	108	<b>I</b>	
Cruise control.....	119	Instrument panel.....	40
<b>D</b>		Interior lighting .....	37
Dashboard .....	38	ITS .....	9
Diesel fuel .....	107		
Doors .....	33		

**J**

Jacking	
front axle .....	140
Rear axle .....	141

**L**

Lubricant, coolant and fuel specifications .....	162
--	-----

**M**

Maintenance	
general.....	103
operations after the winter season .....	108
operations before the winter season .....	106
Master display .....	79
Menu overview .....	84
Menu selector switch.....	82
Mirrors .....	35
Modifications to the vehicle .....	14

**O**

Opening the front panel.....	92
Overview of daily checks.....	92, 110
Overview of weekly checks .....	99

**P**

Paint identification plate .....	169
Parking brake .....	140
Parking brake and service brake.....	125
Power steering fluid level .....	100

**R**

Replacing the fuel fine filter.....	138
Replacing the poly V-belt .....	137
Rev counter.....	40
Roof console .....	36

**S**

Seat belts.....	72
Starting procedure .....	116
Steering .....	123
Steering column switch	
Engine brake .....	67
left .....	65
right .....	66
Steering gear .....	167
Steering lock/contact/starter switch .....	115
Stopping.....	127

**T**

Temperature adjustment.....	60
Tilting the cab .....	134
Tire pressure table .....	161
Towing .....	147
Tyre inflating connection.....	146
Tyre pressure table.....	161

**V**

Vehicle identification plate .....	169
Vehicle speed limitation for special applications.....	122

**W**

Warning indicators .....	45
Warning symbols .....	87
Wheel winch .....	140
Wheels .....	160
Windscreen washer reservoir .....	108



