



**MODEL 270**  
**OPERATOR'S MANUAL**

**California  
Proposition 65 Warning**

Diesel engine exhaust and some of its constituents are known to the State of California to cause cancer, birth defects, and other reproductive harm.

Other chemicals in this vehicle are also known to the State of California to cause cancer, birth defects, or other reproductive harm.

Battery posts, terminals, and related accessories contain lead and lead compounds, chemicals known to the State of California to cause cancer and reproductive harm. Wash hands after handling.

## Foreword

---

# FOREWORD

### How to use this handbook

This handbook contains information for you, the driver, to enable you to operate the vehicle as efficiently and safely as possible and generally to make your driving easier and more satisfying. Besides subjects such as operating instructions, attention also focuses on maintenance and minor repairs which you may be able to carry out yourself.

**i** *NOTE: This handbook is based on the chassis and components as it originally left the factory. Depending upon the required body and equipment, the bodybuilder may have made fundamental changes to various parts or systems, such as the instrument panel, the lighting, or the electrical wiring.*

The vehicles covered by this handbook consist of various types and models. Individual vehicles are constructed in accordance with all Federal Motor Vehicle Safety Standards and in accordance with the expected operating conditions. Certain descriptions or illustrations in this handbook may therefore not correspond entirely to the situation on your own vehicle. However, this has no influence on its operation or maintenance.

**i** *IMPORTANT: Ensure that this handbook is in the vehicle at all times and read it carefully before making your first journey, especially the “**Safety precautions**”, “**Technical items of special impor-***

*tance*”, “*Instruments and controls*” and “*Driving*” sections of this handbook.

In addition to this handbook (available from your dealer) the following publications have also been produced:

Bodybuilders' guidelines  
Maintenance manual

For information on how to order the above publications, please contact your dealer.

### Safety Signals

A number of alerting messages are in this manual. Please read and follow them. They are there for your protection and information. These messages can

help you avoid injury to yourself, your passengers, and help prevent costly damage to the vehicle.

Key symbols and “signal words” are used to indicate what kind of message is going to follow. Pay special attention to instructions preceded by symbols and signal words “WARNING”, “CAUTION”, or “NOTE”. Please do not ignore any of these alerts.

© PACCAR Inc. 9/00

All rights reserved. No part of this publication may be reproduced, stored in a retrieval system, or transmitted, in any form, whether electronic, or mechanical, or by photocopying, recording, or other means without prior permission of PACCAR Inc.

## Foreword

---

### WARNING



When you see this word, the message that follows is especially vital. It signals a **potentially hazardous situation** which, if not avoided, could result in death or serious injury. This message will tell you what the hazard is, what can happen if you don't heed the warning, and how to avoid it.

Example:



**WARNING!** *Never carry additional fuel containers in the vehicle. Such containers, full or empty, may leak, explode or cause a fire in the event of a collision.*

### CAUTION



Signals a **potentially hazardous situation** which, if not avoided, could result in minor or moderate injury or damage to the vehicle.

Example:



**CAUTION:** *Continuing to operate your vehicle with insufficient oil pressure will cause serious engine damage.*

### NOTE



Provides general information: for example, the note could warn you on how to avoid damaging your vehicle or how to drive the vehicle more efficiently.

Example:



**NOTE:** *Pumping the accelerator will not assist in starting the engine.*

Please take the time to read these messages when you see them, and remember:

**WARNING!** Something that could injure you seriously.

**CAUTION:** Something that could cause injury to you or your vehicle.

**NOTE:** Useful information.



## CONTENTS

### **Foreword**

How to use this handbook.....	i
Safety Signals .....	i

### **Contents**

#### **General**

<b>Safety Precautions .....</b>	<b>1</b>
General .....	1
Engine.....	1
Cooling System.....	1
Components.....	2
Electrical .....	2
Oils and Lubricants .....	3
Maintenance Activities .....	3
Chassis Frame .....	3
Vehicle Load .....	4
First Aid Kit.....	4
Winter Driving Conditions .....	4
<b>Items of Special Importance.....</b>	<b>5</b>
Break-in.....	5
Cooling System.....	6
Air Leakage.....	6

System Voltage.....	6
Batteries .....	6
Battery Charging .....	7
<b>Protecting the Environment.....</b>	<b>10</b>
<b>Cleaning the Vehicle.....</b>	<b>11</b>
Cleaning the Cab.....	12
Waxing the Cab .....	12
Cleaning the Cab Interior .....	12

#### **Getting to Know Your Vehicle**

<b>Cab .....</b>	<b>13</b>
Entry and Exit.....	13
Doors.....	14
Tilting the Cab .....	14
Door Mirrors.....	16
Windshield Wiper Blades.....	17
Seats .....	17
Seat Belts .....	18
Storage Tray .....	21
Glove Box .....	21
Sun Visors .....	22
Roof Vent (option).....	23
Courtesy Lights .....	23
Interior Light Unit.....	24
Ashtray .....	24

Cigarette Lighter .....	24
<b>Instruments and Controls.....</b>	<b>25</b>
Instrument Panel .....	26
Switches, Gauges, and Warning Lights on the Instrument Panel .....	28
<b>Chassis.....</b>	<b>46</b>
Towing Pin.....	46

#### **Daily and Weekly Maintenance**

Driver's Check List .....	47
<b>Daily Maintenance .....</b>	<b>50</b>
Front Access Panel .....	50
Engine Oil Level .....	50
Coolant Level .....	51
Wheels And Tires.....	52
Lighting And Instruments .....	52
Driver's Seat And Mirrors .....	52
<b>Weekly maintenance .....</b>	<b>53</b>
Power Steering Fluid Level .....	53
Air Filter Restriction Indicator .....	53
Brake System Air Dryer (optional equipment) .....	54
Clutch Fluid Level.....	55

## Contents

Windshield Washer Fluid Level .....	56		
Tires .....	56		
<b>Driving</b>			
<b>General</b> .....	<b>57</b>	<b>Periodical maintenance</b>	
<b>Ignition Switch</b> .....	<b>57</b>	<b>General</b> .....	<b>71</b>
<b>Starting Procedure</b> .....	<b>58</b>	Maintenance and	
<b>Operating the Transmission</b> .....	<b>58</b>	Lubrication Intervals.....	72
Introduction.....	58	Lubrication Specifications .....	83
Operating Manual Transmissions ..	59	Oil Reservoirs .....	85
Putting the Vehicle in Motion .....	59	Lubrication Chart .....	85
More Transmission Tips .....	61	Maintenance in Special and	
Operating Automatic Transmissions	62	Exceptional Operating Conditions..	88
Operating Automated Manual		Cab Maintenance.....	88
Transmissions.....	63	Preventive Maintenance Before the	
Cruise Control .....	64	Winter Season .....	88
<b>Steering</b> .....	<b>65</b>	<b>Emergency repairs</b>	
<b>Brakes</b> .....	<b>65</b>	Vehicle Tool Kit.....	93
Service brakes.....	66	Replacing The Drive Belt .....	93
Parking brake / emergency brake..	66	Replacing The Compressor Belt....	93
Engine Retarder (option) .....	67	Replacing The Fuel Filter.....	94
<b>Stopping</b> .....	<b>69</b>	Adjusting The Brakes.....	94
Parking .....	69	Spring Brakes — Manual Release.	94
Turning off the engine.....	69	Jacking The Vehicle .....	96
<b>Diesel Fuel</b> .....	<b>70</b>	Wheels.....	97
Cold Weather Recommendations .	70	Towing Pin.....	99
		Towing.....	99
		Replacing Bulbs.....	100
		Fuses.....	103
		Radio (optional) .....	103
		Electrical Connections.....	104
		Speakers .....	104
		<b>Noise and Emission Control</b> .....	<b>105</b>
		Noise Emission Warranty .....	105
		Inspection and Maintenance	
		Instructions .....	106
		<b>Consumer Information</b>	
		<b>and Vehicle Identification</b>	
		<b>Reporting Safety Defects</b> .....	<b>109</b>
		<b>Vehicle Identification</b> .....	<b>109</b>
		Complete Vehicle Certification	
		Label.....	111
		Incomplete Vehicle Certification	
		Label.....	111
		Tire and Rim Information Label ...	111
		Noise Emission Label.....	112
		Paint Data Label .....	112
		Federal Safety Standard	
		Certification Label .....	112
		Component Identification.....	113
		<b>General Alphabetical Index</b>	



## Safety Precautions

---

### GENERAL

#### Safety Precautions



**The following list of safety precautions against possible safety hazards is not exhaustive and, therefore all safety related workshop practices and precautions must be exercised.**

#### General

Ensure all Warnings and Cautions listed in this publication are strictly adhered to. Always read carefully the instructions printed on labels or

stamped on components and obey them completely. Such instructions are included for your health and safety; do **not** disregard them.

Wear clean protective clothing or apparatus when necessary.

#### Engine

Do **not** run engine in a confined space or unventilated area or with a leaky exhaust system. If the engine must be run in a confined space ensure that an exhaust extractor is used.

To prevent a possible fire risk, ensure that the engine and its surrounding areas are clean and free from leakages/spillages of any inflammable liquids (e.g. fuel oil, engine oil, etc.).

#### Cooling System

Do **not** attempt to remove the surge tank filler cap while the engine is running or still hot.

Do **not** attempt to fill a hot engine with cold coolant.

Do **not** fill the cooling system through the pressure cap aperture.

## Safety Precautions

## General

### Components

Ensure that all personnel are clear of any rotating parts or moving components.

Synthetic rubber seals, O-rings and gaskets which have been damaged by fire or come into contact with direct heat, may produce **hazardous fumes** and **highly corrosive chemicals**. Allow burnt or decomposed seals etc. to completely cool. Use impervious protective clothing and gloves. Work in a well ventilated area when handling these components. **In the event of skin contact seek medical attention immediately.**

### Electrical

Batteries contain electrolyte (sulfuric acid) which is a highly corrosive and toxic substance. Accidental skin/eye contact with battery electrolyte can cause serious personal injury.

Always wear protective clothing and suitable eye protection when handling batteries and wash hands after use.



***WARNING! Battery posts, terminals and related accessories contain lead and lead compounds, chemicals known to the State of California to cause cancer and reproductive harm. Wash hands after handling.***

Always disconnect the batteries before commencing work on the vehicle. To minimize the risk of accidental short circuits when disconnecting the batteries,

ensure that the negative (–) lead is disconnected **first** and the positive (+) lead **last**; reverse this procedure when re-connecting the batteries.

To prevent accidental short circuits do **not** place tools/metal objects on or near the battery terminals.

Batteries produce a highly flammable and explosive gas while being charged. It is essential that the area around the battery is well ventilated and protected against any flame, spark or intense heat source. The use of “boost” chargers is **not** recommended.

The ignition switch, steering lock, and its electrical circuits are designed to prevent the auxiliary circuits and starter motor from being energized while the steering lock is engaged. Serious consequences could result from alteration or substitution of the ignition switch and

## Safety Precautions

## General

steering lock or its wiring. Under no circumstances must the ignition switch be separated from the steering lock.

### Oils and Lubricants

Many liquids and other substances used in commercial vehicles are highly toxic. These must **not** be consumed or inhaled and, as far as possible, must be kept from skin contact. These substances, amongst others, include battery acid, anti-freeze, hydraulic fluid, lubricants, fuel, windshield washer fluid, refrigerant, and various adhesives.

Avoid unnecessary contact with used engine oil. Prolonged and repeated contact with used engine oil may cause serious skin disorders.

Extreme care must be taken when draining engine oil; hot engine oil can cause severe personal injury.

### Maintenance Activities

Do **not** use the jack as the sole means of support; position suitable supports beneath the chassis frame.

Do **not** attempt to work on the vehicle with the cab partially tilted.

Do **not** attempt to stand on the cab roof.

### Chassis Frame

Do **not** weld or subject the chassis frame to a severe localized heat source. Failure to observe this precaution may result in irreparable damage to the material structure of the chassis frame with consequent loss in chassis frame strength.

Welding or drilling on the chassis frame must **not** be undertaken without the prior written consent of PACCAR Inc.

Unauthorized, indiscriminate welding or drilling may adversely affect the safe load-carrying characteristics of the chassis frame.

### Welding

- Observe these recommended procedures to protect electronic systems during welding operations.

### All Electronic Engines

Before welding on vehicles equipped with electronic engines, the following precautions should be observed:



*NOTE: Welding to frame rail may void frame rail warranty.*

- Turn engine OFF.
- Disconnect all electronic connections to the vehicle batteries.
- Remove battery power cable and insulate it from the vehicle.

## Safety Precautions

## General

- Disconnect all Electronic Control Module (ECM) connectors (on electronic engines).
- Do not use the ECM or engine ground stud for the ground of the welding probe.
- Ensure that the ground connection for the welder is as close to the weld point as possible. This ensures maximum weld current and minimum risk to damage of electrical components on the vehicle.

### All Anti-Lock Braking Systems (ABS)

Before welding anywhere on the vehicle, detach the ABS Electronic Control Unit (ECU) connector and all other electronic control units.

### Vehicle Load

The load must always be properly secured so that it cannot move while the vehicle is in motion, even during an emergency stop. Side walls, partitions, headboards, etc., are not designed to withstand high forces. Loads must not project more than is permitted by local or national regulations. The stability of the vehicle may be impaired by the load and an increased turning circle may be required.

### Fire Extinguisher

Ensure that you always have a fire extinguisher with you. It should be well secured within hand's reach of the driver and easily accessible for rescue workers and others providing assistance. Have the fire extinguisher checked for operational readiness as

recommended by the manufacturer. When it has been used, have it refilled at the earliest opportunity.

### First Aid Kit

Make sure that you always have a first aid kit with you. Replenish the contents as soon as possible after use.

### Winter Driving Conditions

When winter driving conditions are expected, ensure that your vehicle is prepared in accordance with the recommendations in ["Preventive Maintenance Before the Winter Season" on page 88](#). When severe winter driving conditions are anticipated, ensure that your vehicle is fitted with winter tires or that you have snow equipment, as allowed by state law.

## Items of Special Importance

To prevent damage to the vehicle, the following instructions must be strictly observed.

### Break-in

The following “break-in” recommendations should be applied during the first 1,000 miles (1,600 km) of a new vehicle:

- Do **not** operate at full engine power in any gear.
- Do **not** allow the engine to labor in any gear.
- Do **not** allow the engine to run at idling speeds for excessive periods.

During the “break-in” period do **not** subject the new vehicle to excessive loads; this also applies when an overhauled engine, transmission, or differential has been installed.

**After a cold start** continue to drive in a low gear and at a moderate engine speed until the engine coolant temperature has reached 140°F (60°C).

Check the **instrument panel** regularly when driving and take immediate steps to rectify possible problems at the first sign of trouble.

**Do not let the engine idle for longer than necessary.** This is harmful for the engine and also causes unnecessary pollution of the environment.



**CAUTION:** *In the event of the engine stalling while the vehicle is in motion, power assistance to the steering will be lost and, consequently, greater effort will be required to steer the vehicle.*

The **engine turbocharger** is a precision instrument. For this reason the following operating procedures should be observed:

- When starting the engine, do not allow it to exceed its idling speed for 10 seconds; this procedure will ensure that adequate oil pressure is available at the turbocharger bearings thus preventing initial oil starvation.

## Items of Special Importance

General

- Before stopping the engine, allow it to idle for one to two minutes (particularly if the engine has been subjected to a high speed journey or high engine loadings). This procedure will ensure an adequate oil supply to the turbocharger bearings while the rotor assembly is cooling, thus improving the life span of the turbocharger bearings.
- Any abnormal noises or vibrations from the turbocharger must be reported immediately.

## Cooling System



**CAUTION: Damage to the engine and cooling system, such as corrosion and cavitation erosion, will occur unless antifreeze ZEREX PENRAY 2792 is used and maintained with supplemental**

**coolant additive Pencoool 3000 with Stabil-Aid. As needed, fill or top off the cooling system only with a ready-mixed clean water/approved antifreeze solution using these products. The use of other antifreeze products will void your engine, radiator, and cooling system warranties.**

The engine cooling system is thermostatically controlled, so the **use of a radiator cover** in cold weather is unnecessary.

## Air Leakage

If the **pressure in the air reservoirs** drops rapidly with the engine switched off, this indicates a leak in the compressed air system. Since this affects the safety of the brake system, the leak must be traced and repaired as quickly as possible.

## System Voltage

The vehicle is equipped with a 12 volt negative ground electrical system. When replacing or fitting electrical or electronic components, always verify that they are suitable for this system voltage, polarity, and capacity.

## Batteries

Do **not** disconnect the battery terminals while the engine is running; failure to observe this precaution may result in major damage to the alternator.

Serious battery damage and vehicle starting difficulties will occur if the batteries are discharged ("drained") below 12 volts. To prevent the batteries from being inadvertently discharged, it is essential the following precautions are observed:

## Items of Special Importance

## General

- Ensure that all lights are switched off when not required.
- *Vehicles fitted with a liftgate:* Avoid excessive and severe battery drain when operating the liftgate.

### Battery Charging



**WARNING! Battery posts, terminals and related accessories contain lead and lead compounds, chemicals known to the State of California to cause cancer and reproductive harm. Wash hands after handling.**



**WARNING! Do not try to charge a frozen battery. (Even a battery with ice particles on the electrolyte surface is dangerous.) Allow it to thaw out first. And always allow the battery to thaw gradually—do not apply direct heat. Gas trapped in the ice may cause an explosion.**

First connect the positive (+) terminal of the battery charger to the positive (+) terminal post of the battery and then the negative (–) terminal to the negative (–) terminal post. After charging, switch off the battery charger and then disconnect the negative (–) terminal followed by the positive (+) terminal. For normal charging, the battery cables may remain in place. For fast-charging, both battery cables **must** be disconnected.

### Jump Starting Vehicles

It is **not** recommended that you attempt to jump start your vehicle. If you have a battery problem, it is best to contact a dealer or a reputable towing service.

However, if your battery is discharged (dead), you may be able to start it by using energy from a good battery in another vehicle. This is termed “jump starting.” Be sure to follow the precautions and instructions below.



**WARNING! Batteries can injure you severely. They contain acid, produce poisonous and explosive gases, and supply levels of electric current high enough to cause burns. A spark or flame near a battery on charge may cause it to explode with great force.**

## Items of Special Importance

## General



**WARNING!** Do not allow battery fluid to contact eyes, skin, fabrics, or painted surfaces. Always wear eye protection. Battery acid that may spill during charging should be washed off with a solution of warm water and baking soda to neutralize the acid. If you accidentally get acid in your eyes or on your skin, immediately rinse with cold water for several minutes and call a doctor.

- Be careful that metal tools (or any metal in contact with the positive terminal) do not contact the positive battery terminal and any other metal on the vehicle at the same time. Remove metal jewelry and avoid leaning over the battery.
- If metal jewelry or other metal comes in contact with electrical circuits, a short circuit may

occur causing you to be injured, as well as electrical system failure and damage to the vehicle.

- If the level of electrolyte is low, add distilled water and replace the battery caps before proceeding. If no water is available, remove the battery caps and cover the filler openings with a cloth before proceeding. After jump starting the vehicle, dispose of the cloth.

## To Jump Start Your Vehicle



**WARNING!** The voltage of the booster battery must have a 12-volt rating. And the capacity of the booster battery should not be lower than that of the discharged battery. Use of batteries of different voltage or substantially different capacity rating may cause an explosion and personal injury.



**CAUTION:** Applying a higher voltage booster battery will cause expensive damage to sensitive electronic components, such as relays, and the radio.

- Improper hook-up of jumper cables or not following these procedures can damage the alternator or cause serious damage to both vehicles.



**WARNING!** To avoid serious personal injury and damage to the vehicle, heed all warnings and instructions of the jumper cable manufacturer.

- The jumper cables must be long enough so that the vehicles do not touch.

If either battery has vent caps, remove them and check the fluid level. If it is OK, replace the caps before proceeding. If no water is available, remove the



## Items of Special Importance

## General

caps and cover the filler openings with a cloth before proceeding. After jump starting the vehicle, dispose of the cloth.



**WARNING! If you do not cover the filler openings on the battery, electrolyte could boil out of the openings and hurt someone or damage the vehicle. Replace caps securely if the battery has the full level of electrolyte. If the electrolyte is low and no water is available, cover with a cloth.**

### Preparing the vehicles:

1. Position the two vehicles together, but do not let them touch.
2. Turn OFF all lights, heater, radio, and any other accessories.
3. Set the parking brakes.

4. Ensure that the transmission is in neutral position or, if auto shift, that it is in park position.
5. Turn engine OFF (booster vehicle).
6. Disconnect ground cable on booster battery.

### Connect the batteries:

1. Attach one end of a jumper cable to the positive terminal of the discharged (dead) battery. This will have a large red “+” or “P” on the battery case, post, or clamp.
  - Attach the other end of the same cable to the positive (+) terminal of the good (booster) battery.
  - Attach the remaining jumper cable FIRST to the negative terminal (black “-” or “N”) of the good battery.

- Attach the other end of the negative cable to a bare metal part bolted to the engine block (of the vehicle with the dead battery) or, if possible, clamp directly to the engine block.

*IMPORTANT: Always connect positive (+) to positive (+) and negative (-) to negative (-).*

2. Start the engine:
  - Start the vehicle that has the good battery first. Let it run for a few minutes.
  - Then start the vehicle that has the discharged (dead) battery.

If the engine fails to start, do not continue to crank the starter. Contact the nearest Authorized Service Center.

**Remove jumper cables:**

***WARNING! When disconnecting jumper cables, make sure they do not get caught in any moving parts in the engine compartment. You could be seriously injured.***

- Reverse the above procedure exactly when removing the jumper cables. With engine running, disconnect jumper cables from both vehicles in the exact reverse order (Steps 4 – 1), making sure to first remove the negative cable from the vehicle with the discharged battery.

**Protecting the Environment**

The growing scarcity of the world's natural resources and the escalating problem of pollution pose serious threats to the environment. In order to conserve resources and to minimize pollution it is recommended that the following practices are adopted:

- Do not dispose of used oils, hydraulic fluids, or engine coolant in drains, sewers, water courses, or land-fill sites. These fluids are harmful to the environment and must be disposed of properly.
- Used oils, coolant, and hydraulic fluids should be returned to the appropriate authority for recycling. Ensure that all waste fluid products are segregated and are not intermixed; this practice will increase the efficiency and viability of the recycling process.
- Ensure that the vehicle is regularly serviced to maintain peak efficiency. A correctly maintained vehicle will contribute to maximum fuel economy and a reduction in exhaust gas pollutants.

## Cleaning the Vehicle

Before cleaning the vehicle, check for evidence of leakage around the engine, axles, transmission, etc., because this will not be possible when carrying out service operations after the vehicle has been cleaned.

When a high-pressure cleaner is used, take special note of the following points:

- Ensure that all doors, windows, and cab grille are correctly closed.
- Do not spray directly on seals. There is a danger of the seals being forced open by the high-pressure jet of water so that the grease packed behind them is flushed away.
- The hydraulic fluid reservoir for the steering gear is provided with a ventilation opening. Water may enter the reservoir through this opening and damage the steering gear.
- When cleaning the radiator/inter-cooler, take care not to damage the ribs or fins of the cores.
- Make sure that no water can enter the differential or transmission via the ventilation openings.
- Ensure that no water is allowed to enter the clutch fluid reservoir via the ventilation opening.
- The engine and engine compartment may be cleaned with a high-pressure cleaner. However, do not

aim the jet of water directly at electrical components such as the starter motor, alternator, etc.

- Do not aim the jet of water directly at electrical connections such as connectors, cable feed-through for the vehicle lighting, etc.
- When cleaning the vehicle, make sure that no water enters the air intake system via the air inlet or its flexible joints.



**CAUTION:** After steam cleaning the vehicle, it is essential that all grease points are lubricated with a grease gun or with the automatic chassis lubrication system to prevent moisture and dirt from entering the various pivot points.

## Cleaning the Cab

The external paintwork of the cab is subject to attack by aggressive substances, the severity of which depends upon the specific transport role and operating conditions of the vehicle, for example salt scattered on icy roads, and air pollution. The paintwork must therefore be cleaned regularly.

When cleaning the cab, make sure that:

- no aggressive cleaners are used;
- no stiff brushes are used;

- all seams, gaps, and door frames are thoroughly cleaned.

## Waxing the Cab

To maintain and protect the cab paintwork, it is recommended that a coating of wax is applied at least twice a year.

Your dealer can advise you about additional anti-rust treatment and maintenance of the paintwork when the vehicle is in service.

## Cleaning the Cab Interior

Clean the carpets and seats with a brush or vacuum cleaner and occasionally with diluted upholstery cleaner; do **not** attempt to “dry clean” the carpets or seats.

Clean vinyl faced upholstery and paintwork with a mild household detergent; do **not** use harsh abrasives or solvent-based cleaning solutions.



*NOTE: The appearance of your vehicle is the calling card of your company!*

## GETTING TO KNOW YOUR VEHICLE

### Cab

The equipment, controls, and switches within the cab may vary depending on the vehicle specification.

### Entry and Exit

When entering or exiting the cab observe the following procedures:

- Always face the cab when entering or exiting the cab.
- Always use the grab handles fitted to the driver's and passengers door pillars when entering or exiting the cab.
- Do **not** use the steering wheel or instrument panel as a grab handle.

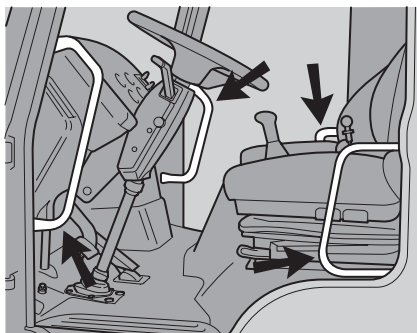

- Always use all cab steps when entering or exiting the cab.
- Do **not** use the fender as a step.



**WARNING! Do not jump out of the cab or get into the cab without proper caution. You could slip or fall, possibly suffering a serious injury.**

*You could slip and fall if the steps are wet or icy, or if you step in fuel, oil, or grease.*

**To help avoid personal injury due to a slip or fall:**

- Use three points of contact (two feet-one hand or one foot-two hands) to grip the steps or handholds whenever possible and look where you are going.
- Use even more care when steps and handholds (or footwear) are wet, coated with ice, snow, mud, oil, fuel, or grease.

## Cab

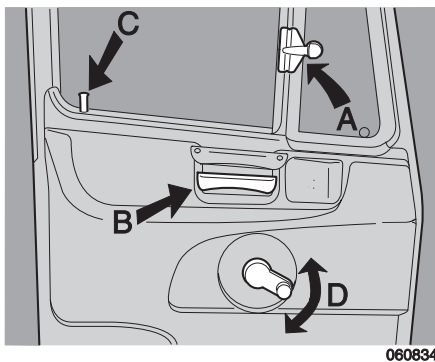

060834

### Doors

Do not drive the vehicle if the doors are not closed.

To open the vent window:

depress the sliding collar and push handle A downwards.

To open the door:

pull handle B upwards.

To lock the door from the inside:  
depress button C.

To open the door window:  
turn the window crank D.

Both doors can be locked and unlocked from the outside with the key.

### Tilting the Cab

The cab is tilted and lowered hydraulically. The cab should only be tilted while the vehicle is parked on level ground.



**WARNING!** You can be seriously injured by the cab if you do not follow safety precautions. Whenever you raise or lower the cab, or when you work under the cab, please remember the following safety rules:

## Getting to Know Your Vehicle

- Ensure that the area in front of the cab is clear.
- Ensure that the vehicle tool kit and hydraulic jack are secured in their stowed positions.
- Ensure that there are no loose objects in the cab.
- Ensure that the engine is switched off, the parking brake is applied, and the shift lever is in neutral position.
- Ensure that the cab tilt cylinder is fully extended before attempting to work on the vehicle.

## Cab

### Tilting

- Ensure that all cab doors and cab grille are closed and secure.
- Rotate the tilt pump spool valve pin (A) to the up position.
- Using the pump handle from the tool kit, operate the hydraulic tilt pump until the cab attains its fully tilted position.

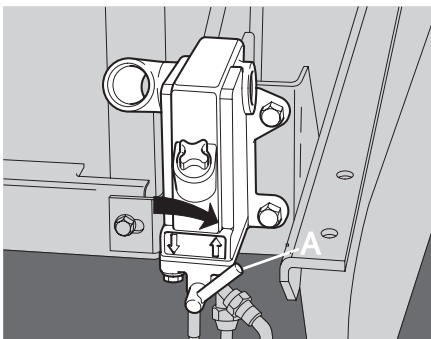

060308



**NOTE:** The cab is secured in the down position by hydraulically operated mounting locks; operation of the tilt pump will automatically disengage the mounting locks.

### Lowering

- Ensure that all personnel are standing clear and that there are no obstructions that would impede the lowering of the cab.
- Ensure that the shift lever is in the neutral position.
- Rotate the tilt pump spool valve pin (A) to the down position.

## Getting to Know Your Vehicle

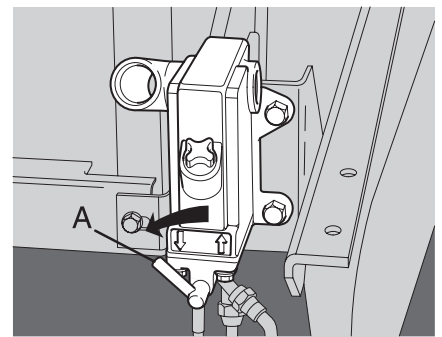

060309

- Operate the hydraulic tilt pump until the cab is fully lowered and the cab mounting locks have automatically engaged. Ensure that the spool valve pin remains in the **down** position while the vehicle is in service.
- Check that the cab is correctly secured by both cab mounting locks. This condition is shown by the lock-down warning light on the

instrument panel. This warning light **must** remain **extinguished** when the ignition is switched on.

## Door Mirrors

This vehicle is equipped with electrically heated door mirrors, a passenger-side mirror and, dependent upon vehicle specification, an auxiliary wide angle mirror (electrically heated).

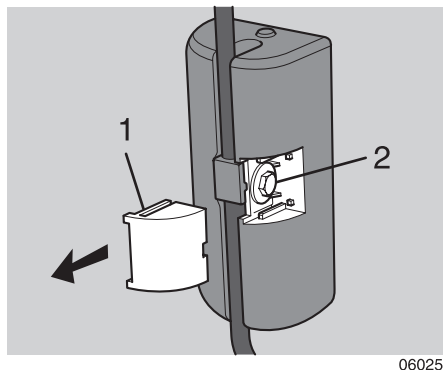

060253

### Mirror head attachment

When required, the attachment of the door mirror head to the mirror arm can be loosened (to aid adjustment) or tightened (to secure in position) using the following procedure:

- Using a suitable implement inserted into the slot provided, release the trim cover (1) and then extract it from its slotted location in the mirror head.
- As applicable, release/tighten the mirror head retaining bolt (2) to 11 lb. ft. (15 Nm).
- When replacing the mirror head trim cover, ensure that it is correctly located within its slotted location and then pushed firmly in to its engaged position; no gaps must exist between the trim cover (slotted end) and mirror head.

### Mirror arm fold positions

The mirror arms are held in position by a detent located under the mirror arm shroud. The detent is equipped with a spring-loaded clutch to enable the mir-



## Cab

ror arms to remain in position during normal conditions; this enables the mirror arms to be folded forward or rearward against the cab when maneuvering the vehicle in a confined space.



**WARNING!** It is unsafe to drive without full visibility to the rear. Do not attempt to drive the vehicle with the mirror arms in the folded position.

## Windshield Wiper Blades

To prevent damage to the wiper blades during operation in winter conditions, always check that the blades are not frozen to the windshield. This can be prevented by placing something under the wiper blades. Clean the wiper blades regularly with water and dry them with a soft cloth.

## Seats



**WARNING!** Do not adjust the driver's seat while the vehicle is moving. The seat could move suddenly and unexpectedly and can cause the driver to lose control of the vehicle. Make all adjustments to the seat while the vehicle is stopped.

- After adjusting the seat and before driving off, always check to ensure that the seat is firmly latched in position.

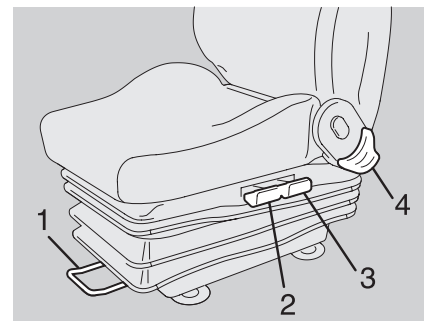

060312

The driver's seat must be adjusted only when the vehicle is stationary. Do not attempt to adjust the seat while the vehicle is in motion.

### Driver's Seat (adjustable)

The driver's seat has the following adjustment modes:

#### Fore/aft adjustment

Pull up **bar 1** and slide the seat to the required position.

#### Seat cushion height adjustment-front

Pull up **handle 2** and adjust the front end of the seat cushion to the required height.

#### Seat cushion height adjustment-rear

Pull up **handle 3** and adjust the rear end of the seat cushion to the required height.

#### Backrest adjustment

Pull up **handle 4** and adjust the backrest to the required position.

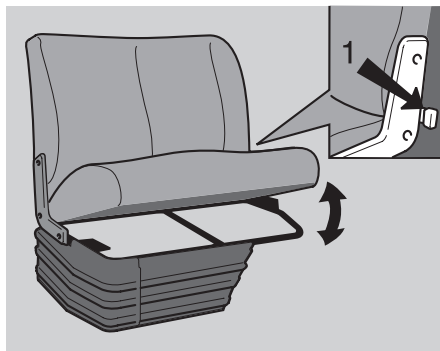

### Passenger's Seat (2-man)

The 2-man passenger seat is fixed and non-adjustable. A storage compartment, containing the vehicle tool kit, is located beneath the seat cushion. To gain access to the storage compartment depress the **lock control lever 1**

and lift the seat cushion. When the seat cushion is fully upright, it will automatically lock in position; depress the lock control lever to release the seat cushion.

### Passenger's Seat (single-adjustable)

The single passenger's seat can be adjusted for fore/aft position, seat cushion height, and backrest rake. Refer to "Driver's Seat (adjustable)" for the adjustment procedures.

### Seat Belts

The driver's seat and passengers seat are equipped with seat belts, these should be worn by the seat user when the vehicle is in motion.

## Cab

## Getting to Know Your Vehicle



**WARNING!** Do not drive vehicle without your seat belt and your riders' belt fastened. Riding without a safety belt properly fastened can lead to increased injury or death in an emergency. Unbelted riders could be thrown into the windshield or other parts of the cab or could be thrown out of the cab. They could strike another person. Injuries can be much worse when riders are unbelted. Always fasten your seat belt and be sure anyone riding with you does the same.



**WARNING!** Always wear your seat belt low over your pelvic bones.

- You can be seriously injured if your belt is buckled too high. In a crash, it would apply force to

your abdomen, not your pelvic bones. This can result in serious internal injuries.

- Do not drive with your seat belt loose. A too-loose seat belt can allow you to fall too far forward, possibly causing head and neck injuries. You could strike the wheel or the windshield. Adjust your belt so that there is no more than 1 in. (25mm) of slack.



**WARNING!** Do not wear the shoulder part of belt under your arm or otherwise out of position. In a crash your body would move too far forward, increasing the chance of head and neck injury. Also, the belt would apply too much force to the ribs, which are not as strong as your shoulder bones, and could cause you to suffer internal injuries. Wear the shoulder belt over your shoulder.



**WARNING!** Do not twist the belt in the process of putting it on. A twisted belt will not work as well to protect you. In a crash, the full width of the belt would not be protecting you. A twisted belt could cut into your body and cause serious injuries. Straighten the belt before buckling it. If you are unable to wear it without twisting it, have your dealer or service person replace it as soon as possible.

Observe the following recommendations:

- Do not use any seat belt for more than one person.

- Before securing a seat belt, ensure that the webbing is not twisted, looped or obstructed in any way that could impair the operating mechanism.
- Optimal safety can be offered by a seat belt only when it is properly tightened.
- Never have repairs or modifications made to the seat belts.
- Replace the seat belt when the webbing is worn or damaged.
- If the seat belts have been subjected to high loading during a collision, then the complete assembly must be replaced, even if there is no visible evidence of damage.

#### **Seat belt upper anchorage adjustment**

The seat belt upper anchorage point should be adjusted so that the belt webbing crosses **midway between the user's neck and the edge of the shoulder**.

To adjust the position of the upper anchorage point, depress the locking button and, simultaneously, slide the anchorage point to the desired position; release the locking button when the required position is obtained.

#### **Seat belt care**

- Regularly inspect all seat belt webbing, anchorage points, and locking mechanisms for correct operation and for evidence of excessive wear or damage.

- Check the seat belt locking action by rapidly pulling the belt webbing out of its retracting unit; the belt webbing **must** lock, i.e. it must not be pulled out of the retracting unit.
- Do **not** clean the belts with aggressive cleaning agents; if necessary, use an all-purpose cleaner.

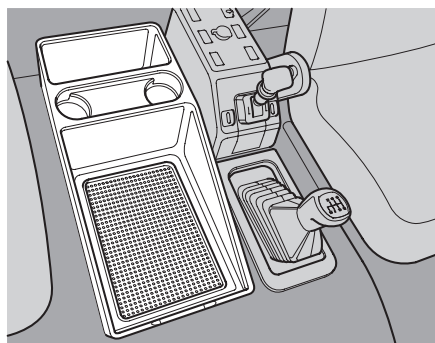

### Storage Tray

Your truck may be equipped with a fixed storage tray. The storage tray is of a pre-formed construction incorporating storage bins and cup holders.

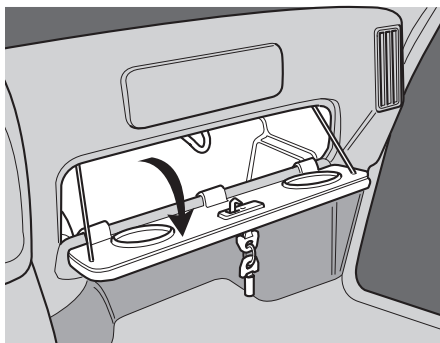

### Glove Box

All vehicles are equipped with a lockable glove box.



*NOTE: The "Operator's Manual" is stored in the glove box. Keep this book in the cab at all times.*

## Sun Visors

The cab is fitted with 3 sun visors which are provided for the driver and passenger. The sun visors can be swung down to block the sun.

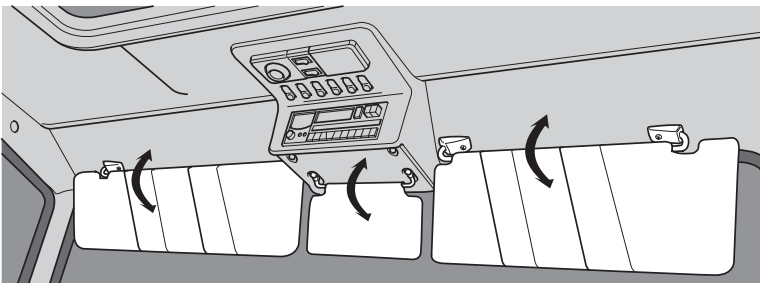

060728

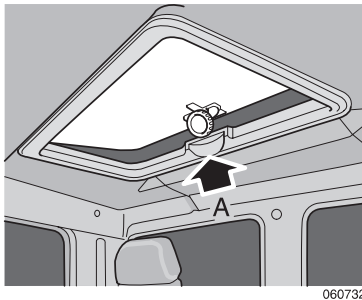

### Roof Vent (option)

Rotate the control knob (A) to open and raise the roof vent to the required position.

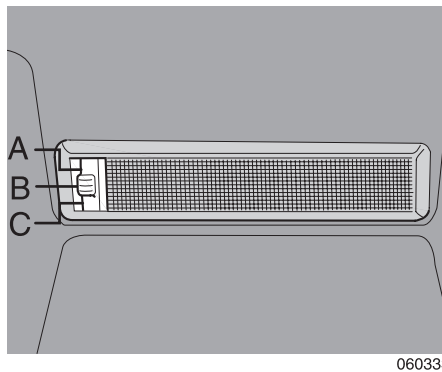

### Courtesy Lights

All cabs are equipped with two courtesy lights which are fitted in the cab roof lining above each door.

The courtesy light switch has three positions:

Position A: the light will only illuminate when the door is opened.

Position B: light is switched off.

Position C: light is on permanently.

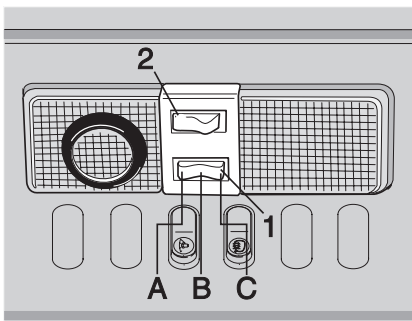

### Interior Light Unit

All cabs are equipped with an interior light unit which is fitted in the cab center roof panel. The interior light unit incorporates a directable reading light and a courtesy interior light; both lights are independently operated using the interior light mounted switches.

### Courtesy interior light

The courtesy interior light switch (1) has three positions:

Position A: light is switched off.

Position B: light is switched off.

Position C: light is switched on.

### Reading light

The reading light is operated by the on/off switch (2); the light beam can be directed to the required position by moving the swivel lens.

### Ashtray

An ashtray is provided in the center panel. Raise the cover to open the ashtray. To empty the ashtray, close the cover and extract the complete ashtray unit from its holder. Replace the ashtray by reversing the removal procedure.

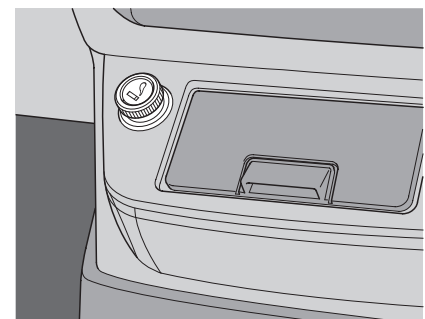

### Cigarette Lighter

A cigarette lighter is provided in the center panel adjacent to the ashtray. Depress the cigarette lighter in its socket; the cigarette lighter will partially eject when ready for use.

The cigarette lighter can be used as a 12 volt accessory power supply. Before connecting electrical equipment to the



## Instruments and Controls

cigarette lighter socket it is **essential** to ensure that:

- only 12 volt (negative ground) electrical equipment is connected to the cigarette lighter power socket.
- the power consumption of any electrical component does **not** exceed **10 amps**.

## Instruments and Controls

### General

The instruments and controls are located on the instrument panel, center console, center roof console, and steering column.

### Warning Lights

All warning lights are color coded to indicate the level of their importance. The color codes and the required driver's response are as follows:

#### Red

Illumination of any red warning light during normal driving conditions indicates a major system or equipment malfunction. In the event of any red warning light illuminating, the vehicle must be stopped and the engine switched off. Do not attempt to drive the vehicle until the fault has been fixed.

#### Amber

Illumination of any amber warning light during normal driving conditions indicates an equipment/system malfunction. In the event of an amber warning light illuminating, the vehicle may con-

## Getting to Know Your Vehicle

tinue on its journey but additional driving caution must be observed. The fault should be fixed at the earliest opportunity.

### Green Or Blue

Illumination of any green or blue warning light indicates that a unit/system is operational.



***WARNING! Do not ignore a warning light or buzzer. These signals may tell you something is wrong with your vehicle. It could be a failure in an important system, such as the brakes, which could lead to an accident. Have the appropriate system checked immediately.***

### Instrument Panel

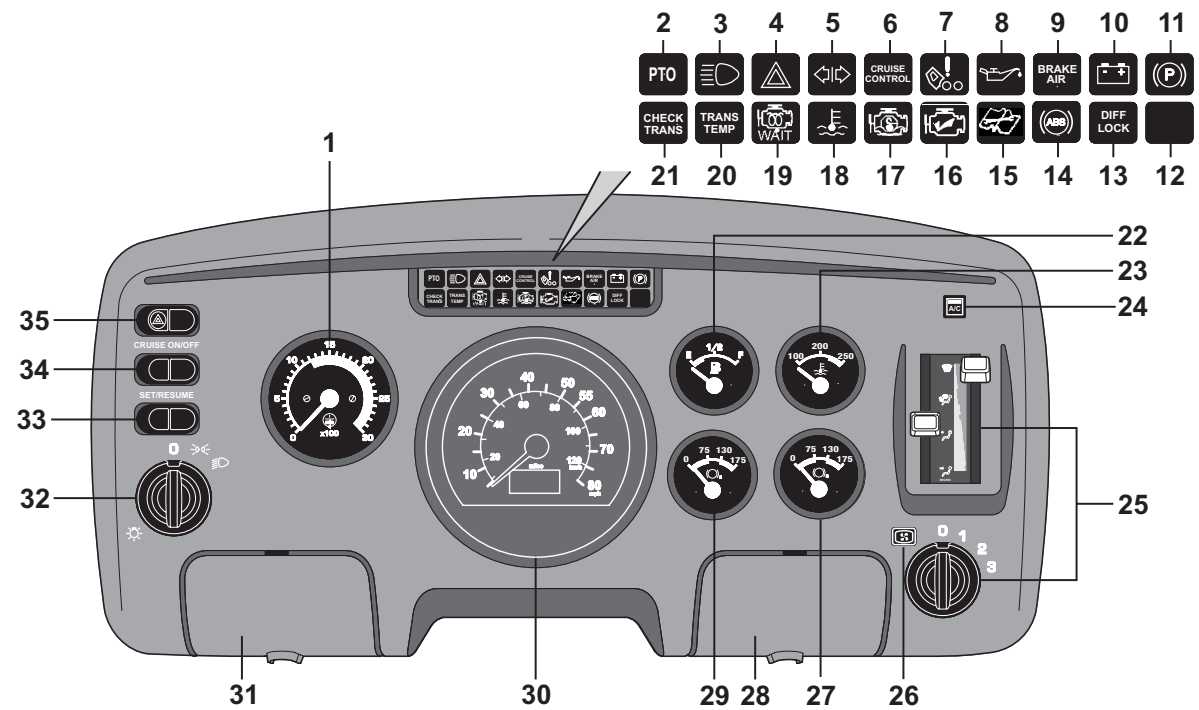

---

**Instruments and Controls****Getting to Know Your Vehicle**

---

- |  |  |                                      |
|--|--|--------------------------------------|
| 1. Tachometer                          | 13. Differential lock warning light            | 24. A/C On-Off switch                |
| 2. PTO warning light                   | 14. ABS warning light                          | 25. Heating and ventilation controls |
| 3. High beam warning light             | 15. Maintenance - Water in Fuel                | 26. Ventilation fan indicator light  |
| 4. Hazard switch warning light         | 16. Check engine warning light                 | 27. Air pressure gauge - (secondary) |
| 5. Turn signal warning light - vehicle | 17. Stop engine warning light                  | 28. Fuse box - right                 |
| 6. Cruise control warning light        | 18. Coolant temperature warning light          | 29. Air pressure gauge - (primary)   |
| 7. Cab-lock warning light              | 19. Wait to Start engine warning light         | 30. Speedometer/odometer             |
| 8. Oil pressure warning light          | 20. Transmission oil temperature warning light | 31. Fuse box - left                  |
| 9. Low air pressure warning light      | 21. Check transmission warning light           | 32. Vehicle lighting switch          |
| 10. Battery charge warning light       | 22. Fuel gauge                                 | 33. Cruise control Set/Resume switch |
| 11. Parking brake warning light        | 23. Coolant temperature gauge                  | 34. Cruise control On-Off switch     |
| 12. Not used                           |  | 35. Hazard warning light switch      |

## Switches, Gauges, and Warning Lights on the Instrument Panel

### 1. Tachometer

White field: low-idling speed

Green Field: economical speed range

Yellow field: maximum power range

Red field: excessive/overspeed range (not permitted)

### 2. PTO Warning Light

(A PTO is not available from the factory.) This warning light will illuminate whenever the PTO is engaged.

Do not drive vehicle at highway speeds if PTO is engaged (light is ON).

### 3. High Beam Warning Light

This warning light will illuminate whenever the headlights are in the high beam position or when the headlight flash is operated.

### 4. Hazard Switch Warning Light

This warning light will flash simultaneously in conjunction with both direction indicators whenever the hazard warning light switch is activated.

### 5. Turn Signal Warning Light - Vehicle

This warning light flashes in conjunction with the vehicle turn signals.

### 6. Cruise Control Warning Light

This warning light will illuminate whenever the cruise control is switched ON.

### 7. Cab-lock Warning Light

This warning light will illuminate and a warning buzzer will sound if the cab is not correctly locked in the down position; this warning light is only operative while the ignition is switched on. Also see the "Cab" section of this handbook.

Do **not** attempt to drive the vehicle while this warning light is illuminated.

### 8. Oil Pressure Warning Light

This warning light will illuminate and a warning buzzer will sound when the engine oil pressure is too low. In the event of the oil pressure warning light illuminating during normal driving conditions, the vehicle **must** be stopped and the engine switched off. Do **not** attempt to re-start the engine until the fault has been rectified.



**WARNING!** *The air pressure warning light and the audible alarm indicate a dangerous situation: there is not enough air pressure in the reservoirs for repeated braking and, except when the engine is started, indicates the brake system has failed. Without the use of your service brakes your spring brakes could suddenly apply causing a wheel lock-up, loss of control, or over-take by following vehicles. You could be in an accident and severely injured.*

- **Bring the vehicle to a safe stop right away, while you still have control of the vehicle. Follow the procedure below:**

#### **Air Loss Emergency Procedure**

1. Slow down carefully.
2. Move a safe distance off the road and stop.

3. Place the transmission in park and set the parking brake. (See pages [58](#) and [66](#) for transmission shifting and parking brake information.)
4. Turn OFF the engine.
5. Turn ON the emergency flasher and use other warning devices to alert other motorists.

If the light and alarm do not turn off at startup, do not try to drive the vehicle until the problem is found and fixed.

#### **9. Low Air Pressure Warning Light**

This warning light will illuminate and a warning buzzer will sound whenever there is insufficient air pressure (less than 80 psi or 5.5 bar) available in any air reservoir.

Do **not** attempt to drive the vehicle while this warning light is illuminated.

#### **10. Battery Charge Warning Light**

This warning light will illuminate if the battery charging voltage falls below 11 volts.

#### **11. Parking Brake Warning Light**

This warning light will illuminate whenever the parking brake is applied or when there is insufficient air pressure available to release the parking brake.

#### **12. Blank**

This warning light is not used.

#### **13. Differential Lock Warning Light**

(A locking differential is not available from the factory.) This warning light will illuminate whenever the differential is locked.

#### 14. ABS Warning Light

This warning light monitors the vehicle anti-lock braking system (ABS). This warning light will illuminate when:

- the ignition is switched on; the light should extinguish as soon as the vehicle road speed exceeds 5 mph (7 km/h);
- the vehicle ABS is defective; the conventional braking will remain operative but the vehicle must be driven with care and the ABS must be rectified at the earliest opportunity.

Also see “*Driving*” and “*Emergency repairs*” sections of this handbook.

#### 15. Maintenance - Water in Fuel

This warning light will illuminate if the water/fuel separator needs to be drained.

#### 16. Check Engine Light

This warning light will illuminate when an engine problem exists, but the vehicle can still be safely driven. The vehicle should be serviced to correct the problem but the situation should not be considered an emergency.

#### 17. Stop Engine Light

This warning light will illuminate when a major engine problem exists. It means you should stop and shut down your vehicle as soon as it is safely possible.



**NOTE:** *If you need to determine the exact engine problem that turns on warning light 16 or 17,*

*you must access the on-board diagnostic system. With the key switch ON but the engine NOT running, press the throttle pedal to full throttle and release to idle three times. The active fault codes will flash out as described in the Cummins ISB Engine Operation and Maintenance Manual. Contact your dealer or the Cummins engine service center for the explanation of the code. Turn the key switch OFF to exit the diagnostic mode.*

#### 18. Coolant Temperature Warning Light

This warning light will illuminate and a warning buzzer will sound whenever the engine coolant temperature exceeds the maximum permissible level.

**19. Wait to Start Light**

This warning light will illuminate when the air intake heater is ON. Do not attempt to start the engine until the light goes out.

**20. Transmission Oil Temperature Warning Light**

(Functional only if optional Allison automatic transmission is installed.) This warning light will illuminate whenever the transmission oil temperature exceeds the maximum permissible level.

**21. Check Transmission Warning Light**

(Functional only if optional Allison automatic transmission is installed.) This warning light will illuminate when a problem exists with the transmission,

but the vehicle can still be safely driven. The vehicle should be serviced to correct the problem, but the situation should not be considered an emergency.

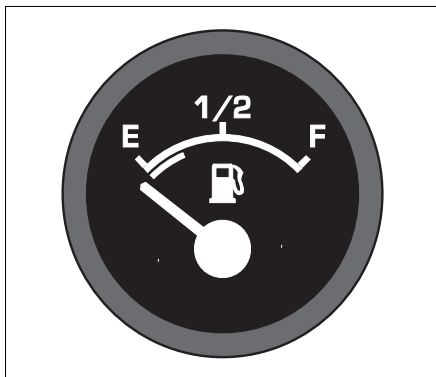
**22. Fuel Gauge**

The fuel gauge gives an approximate indication of the fuel tank contents and only operates with the ignition switched on.

Instruments and Controls

Getting to Know Your Vehicle

**23. Coolant Temperature Gauge**

The coolant operating temperature should be between 165°F (74°C) and 198°F (92°C). At a temperature of less than 140°F (60°C) the engine should not be fully loaded by the driver. If the coolant temperature suddenly rises and/or the gauge pointer enters the red field, then the following items should be checked:

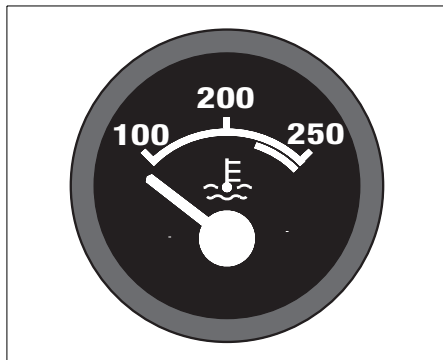

- The coolant level. See [“Coolant Level”](#) on page 51.
- The drive belt and water hoses.
- The operation of the viscous fan drive.



**24. A/C On/Off Switch**

(With optional air conditioning only)  
This switch turns the air conditioner compressor and the remotely mounted condenser on and off.

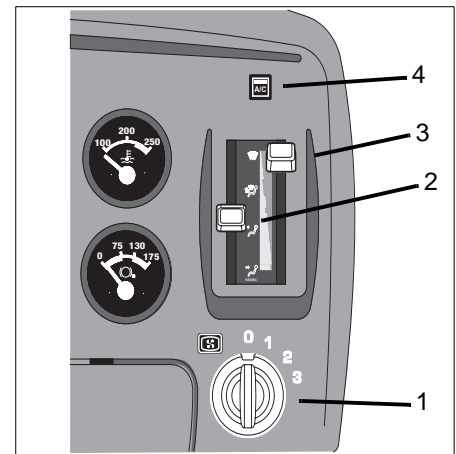

**25. Heater And Air Conditioner Controls**



**WARNING!** Do not drive with your visibility reduced by fog, condensation, or frost on the windshield. Your view may be obscured, which could result in an injury



## Instruments and Controls

**accident. For clear visibility and safe driving it is extremely important for you to follow the instructions on the use of the ventilation/heating and defogging/defrosting system. If in doubt, consult your dealer. Maximum heating output and fast defrosting can be obtained only after the engine has reached operating temperature.**



**WARNING! Excessive heat may cause the pressurized components of the air conditioning system to explode. Never weld, solder, steam clean, or use a blow torch near any part of the air conditioning system.**

- **If a refrigerant leak develops in the presence of excessive heat or an open flame, hazardous gases may be generated. These gases may cause unconsciousness or death. If you become**

**aware of a refrigerant leak on your vehicle, have your system serviced immediately and observe the following precautions:**

- **Stay away from the hot engine until the exhaust manifold has cooled.**
- **Do not permit any open flame in the area. Even a match or a cigarette lighter may generate a hazardous quantity of poisonous gas.**
- **Do not smoke in the area. Inhaling gaseous refrigerant through a cigarette may cause violent illness.**

The heating and air conditioner controls are located on the instrument panel.

The heater and air conditioner controls consist of a rotary switch for regulating the blower speed, a slide control for selecting air distribution, a slide control

## Getting to Know Your Vehicle

for selecting air temperature, and with optional air conditioning, a push button switch for turning the air conditioning on or off.

## 22. Ventilation Fan Indicator Light

When illuminated, indicates the blower switch is on (Positions 1-3).

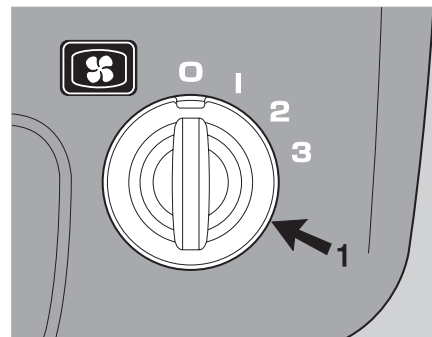

060317



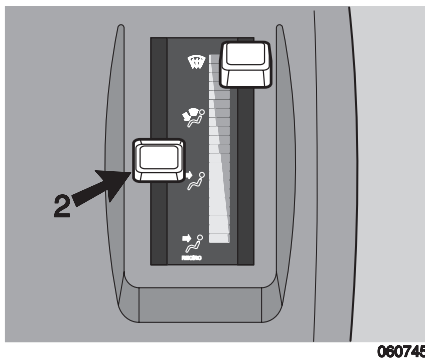

**Rotary switch (1)** Controls the blower speed (3 speeds and an off position).

## Instruments and Controls

## Getting to Know Your Vehicle



**Slide control (2)** Controls the air distribution within the cab.

-  = Windshield
-  = Floor
-  = Panel (Fresh)
-  = Panel (Recirc)

A bi-level mode exists when the slide control is placed between Windshield and Floor positions or between Floor and Panel (Fresh) positions.

The optional air conditioner compressor is engaged when the control is placed in Windshield mode (top-most position).

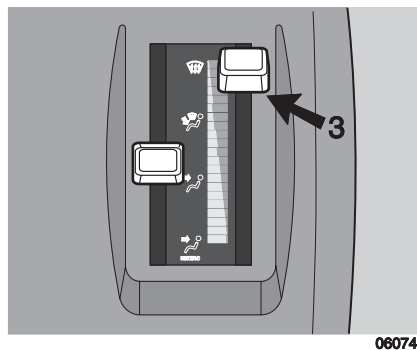

**Slide control 3.** Controls progressive adjustment of the heater from 0 to 100% output.

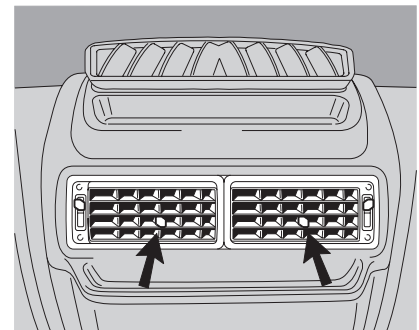

### Air vents and defoggers

The heater and air conditioner system has fixed and adjustable air vents for windshield defogging, heating or cooling the interior of the cab, defogging the door glass, and heating or cooling the footwell area.

The **center panel** has two air vents, adjustable for direction and volume of air flow.

## Instruments and Controls

## Getting to Know Your Vehicle

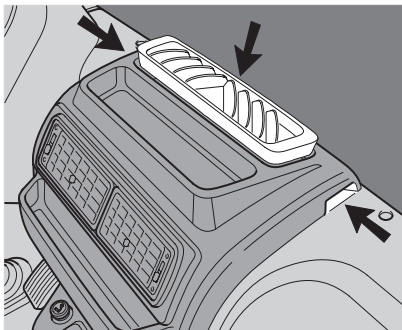

The **center panel** incorporates a central defogger with two integral side vents for defogging the entire width of the windshield.



**NOTE:** *The central defogger outlet is fitted with a protective mesh to prevent the entry of foreign objects. To maintain maximum air flow efficiency, do **not** place objects on the protective mesh or obstruct the central defogger in any way.*

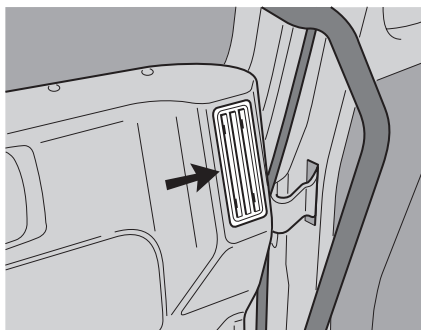

060322

Two fixed air outlets at the left and right of the cab fascia are directed at the door glass. These vents and outlets admit heated or cooled air into the cab.

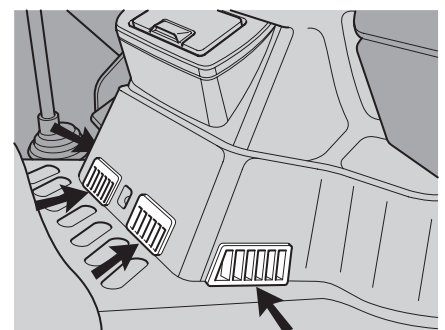

060749

**In the footwell area** there are four outlets which are not adjustable for direction of the air flow. These vents and outlets admit heated or cooled air into the cab.

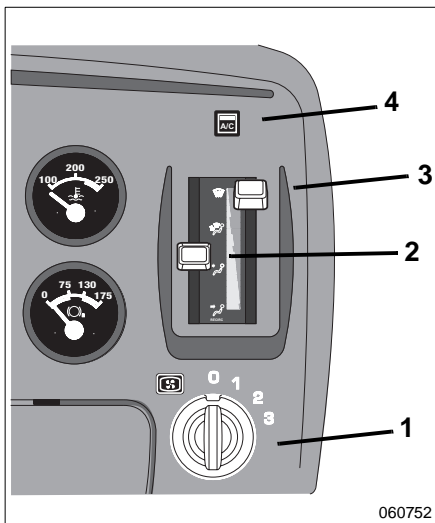

060752



**NOTE:** For the remainder of the Heating section, numbers in parentheses ( ) refer to items shown in this figure .

### Heating

To heat the cab: select the desired air distribution (2) and temperature (3) to hot (red position on the control). Adjust the fan speed (1) as desired.



**CAUTION:** During extreme cold weather, do not blow hot air onto cold windshields. This could crack the glass. Turn the air direction lever to Defrost and adjust the fan speed accordingly while the engine warms. If the engine is already warm, move the temperature selector to Cool, then gradually increase the temperature when you see that the windshield is starting to warm up.

CONTROLS	HEATING A/C CONTROL					
	HEATING		COOLING		DEFOGGING	
	MAX	NML	MAX	NML	MAX	NML
Fan Speed (1)	High	Adjust	High	Adjust	High	Adjust
Air Distribution (2)	Panel	Panel or Bi-Level	Recirc	Adjust	Windshield	Windshield or Bi-Level
Temperature (3)	Warm	Adjust	Cool	Adjust	Warm	Adjust
Air Conditioner - AC (4)	OFF	OFF	ON	ON	—	—

## Instruments and Controls

### Defogging



*NOTE: If equipped with optional air conditioning, the air conditioning system is active when the Defrost mode is selected.*

To defog the windshield: select air distribution to Windshield or between Windshield/Floor and turn the fan speed switch (1) to high. Set the temperature control (3) to hot (red position on the control). The air conditioner (if equipped) is automatically activated to remove moisture from the cab. After the windshield is clear, adjust the controls as desired.

### Cooling

To cool the cab: turn on the air conditioner (if equipped) (switch 4), set the temperature control (3) to cool (blue

side), and the fan (1) to high until the cab becomes cool—adjust as desired.

When set to Recirc mode, the air conditioning system will automatically shut off fresh air intake and will recirculate cab air.

### For Efficient Cooling:

1. Ensure all heater/air conditioner controls are off.
2. Start the engine. Allow time for warm-up.



*NOTE: A cold compressor can cause refrigerant to liquefy and warp the valve plates or cause a hydraulic lock. Warm the engine before starting the air conditioner.*

3. Set the air conditioner for maximum cooling.
4. Close all windows.

5. Idle the engine between 1,000 and 1,500 rpm and turn the fan switch to High.
6. After the cab temperature cools to a comfortable level, adjust the fan speed and other controls to keep the desired condition.
7. For efficient air flow in fresh air mode, regularly clean the HVAC filter located on the bottom of the cab. First, place the system in "recirc" mode and then clean the filter with a low pressure air hose.
  - If the air conditioner does not cool the air, have the unit checked at an Authorized Service Center.



*NOTE: When the air conditioner isn't in regular use, operate it for at least 15 minutes at least once a month or every 5,000 miles (8,000 km), whichever comes first. This will lubricate the seals in the air conditioning system.*

## Getting to Know Your Vehicle

Instruments and Controls

Getting to Know Your Vehicle

**27. Air Pressure Gauge “Secondary”**

Air gauge “2” constantly monitors the air pressure in the rear brake reservoir. At reservoir air pressures below 80 psi (5.5 bar) a warning buzzer will sound and a warning light, mounted in the instrument panel, will illuminate; the warning buzzer and warning light are only operative while the ignition is switched on. Do **not** attempt to drive the vehicle with less than 80 psi (5.5 bar) of air pressure.

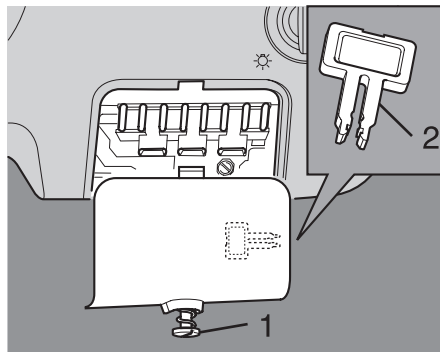

080995

**29. Air Pressure Gauge “Primary”**

Air gauge “1” constantly monitors the air pressure in the front brake reservoir. At reservoir air pressures below 80 psi (5.5 bar) a warning buzzer will sound and a warning light, mounted in the instrument panel, will illuminate; the warning buzzer and warning light are only operative when the ignition is switched on. Do **not** attempt to drive the vehicle with less than 80 psi (5.5 bar) air pressure.

**28. Fuse Box - Right**

To gain access to the circuit and spare fuses, rotate the quick release fastener (1) using a coin and then slide the fuse cover downward. To enable the fuses to be easily removed, a fuse extraction tool (2) is attached to the inside of the fuse cover. Also see the “*Emergency repairs*” section of this handbook.

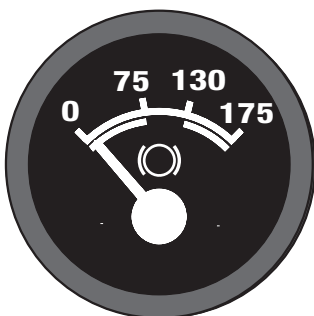

060751

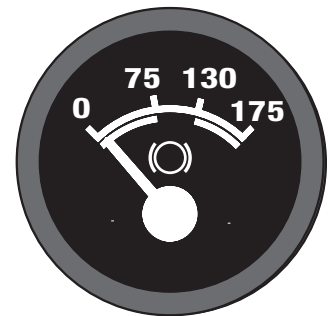

060751

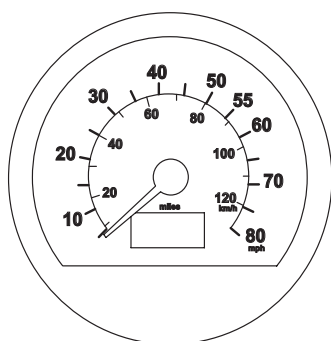

### 30. Speedometer/Odometer

The speedometer indicates the vehicle speed in miles per hour (MPH) and in kilometers per hour (kph)

The odometer records the distance traveled by the vehicle, either in miles or kilometers, depending on which unit is installed in the vehicle.

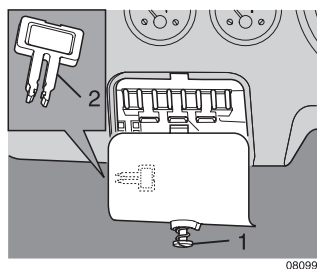

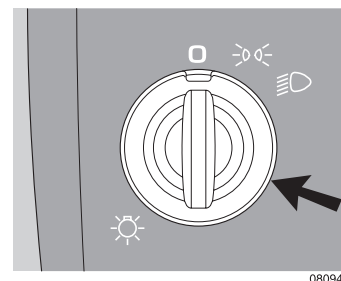

### 31. Fuse Box - Left

To gain access to the circuit and spare fuses, rotate the quick release fastener (1) using a coin and then slide the fuse cover downward. To enable the fuses to be easily removed, a fuse extraction tool (2) is attached to the inside of the fuse cover. Also see the “*Emergency repairs*” section of this handbook.



### 32. Vehicle Lighting Switch

The vehicle lighting is operated by a rotary type switch with three positions:

-  lighting switched off
-  side lights, instrument panel, and cab marker lights
-  headlights, side lights, instrument panel, and cab marker lights

### 33. Cruise Control Set/Resume Switch

This switch allows the desired speed to be set or resumed after the cruise control function is turned on or interrupted.

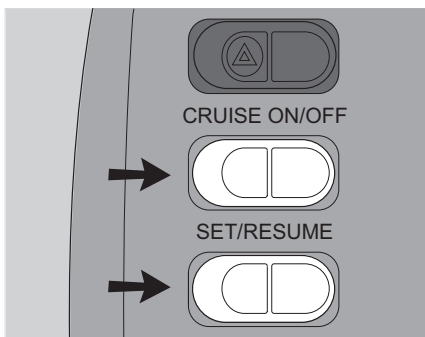

081175A

### 34. Cruise Control On/Off Switch

This switch turns the cruise control function ON or OFF.



**WARNING!** Do not operate the cruise control when operating on road surfaces with poor traction (wet, icy, or snow covered roads) or in heavy traffic. Accelerations caused by the normal operation of the cruise control could cause you to lose control of the vehicle resulting in an injury accident.

### 35. Hazard Warning Light Switch

Activating this rocker type switch causes all the turn signals to flash simultaneously; a warning light on the instrument panel will illuminate while the hazard lights are working. Return the rocker switch to its off position to cancel the hazard lights.

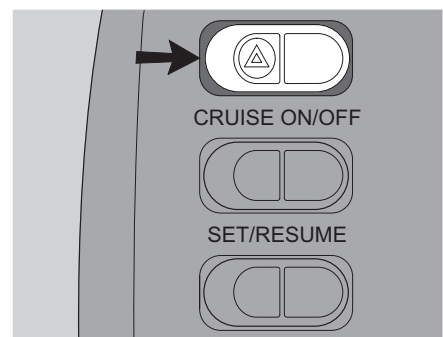

081175



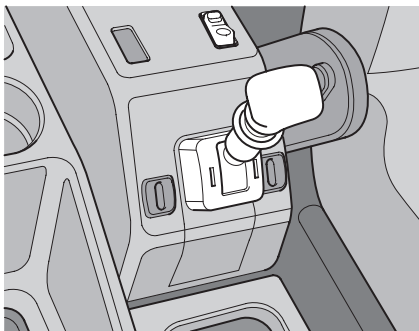

070577

### OPERATING LEVER, PARKING BRAKE

This lever is used to actuate the parking brake. Also see the “Driving” section of this handbook.



**WARNING!** *Never drive your vehicle with the parking brake applied. Always release the parking brakes prior to moving the vehicle. Failure to disengage the parking brakes prior to moving your vehicle could result in excessive heat build-up in the brake system, resulting in a fire.*



**NOTE:** *Today's diesel electronic engines have significant torque and startability power at low RPM. Combinations of engine speed and available torque may over-power the vehicle's parking brakes.*

### CENTER ROOF CONSOLE

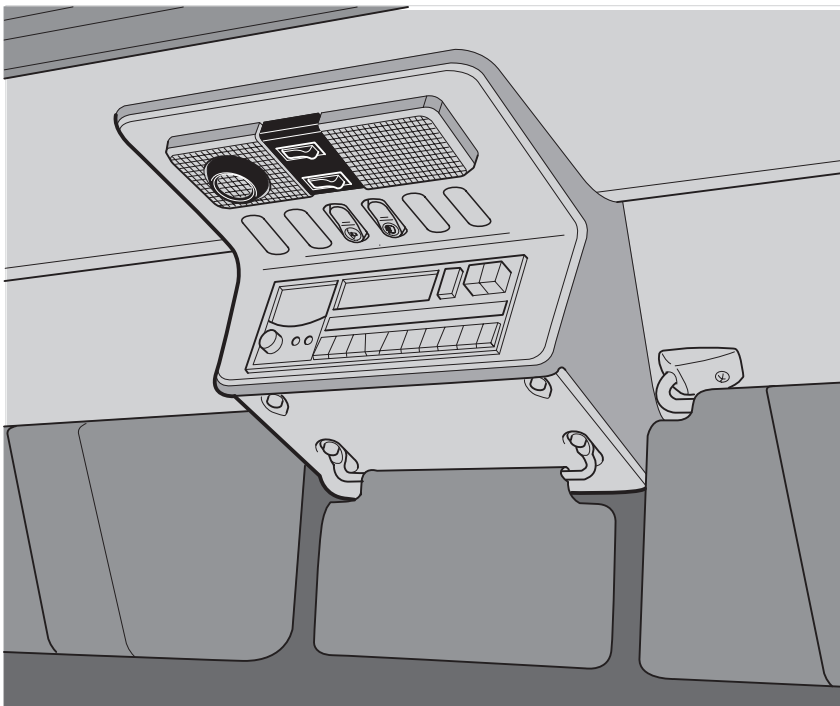

*NOTE: Optional radio shown*

081146B

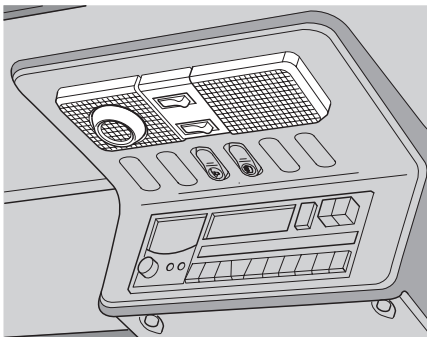

081147A

### Interior Light

The interior light unit incorporates a directable reading light and a courtesy interior light; both lights are independently operated using the interior light unit mounted switches. Refer to the “Cab” section of this handbook for the interior light unit operating procedures.

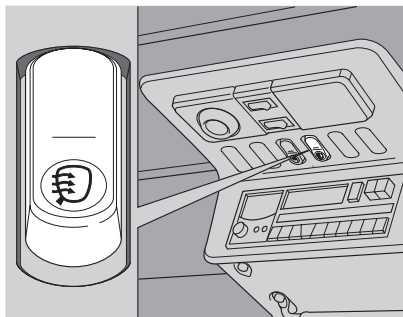

081133A

### Mirror Heating Switch

The door mirror heating can be activated with this switch. When the door mirror heating is on, the switch warning light will illuminate.



**CAUTION:** The mirror heating must be switched on only for the period of time required to clear moisture from the mirror glass; excessive use may damage the mirror and the heating element.

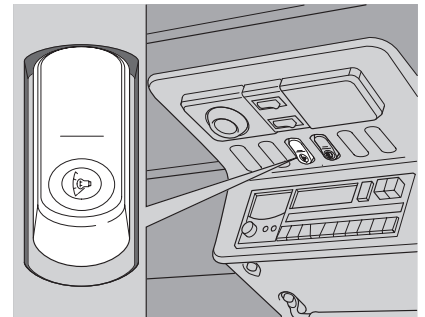

081133B

### Instrument Panel Lighting Switch

The instrument panel will automatically illuminate when the lights are switched on. The intensity of the instrument panel illumination can be increased by activating this rocker switch. Return the rocker switch to its off position to revert to low level illumination.



**NOTE:** Optional radio shown on this page

Instruments and Controls

**Controls Around The Steering Column**

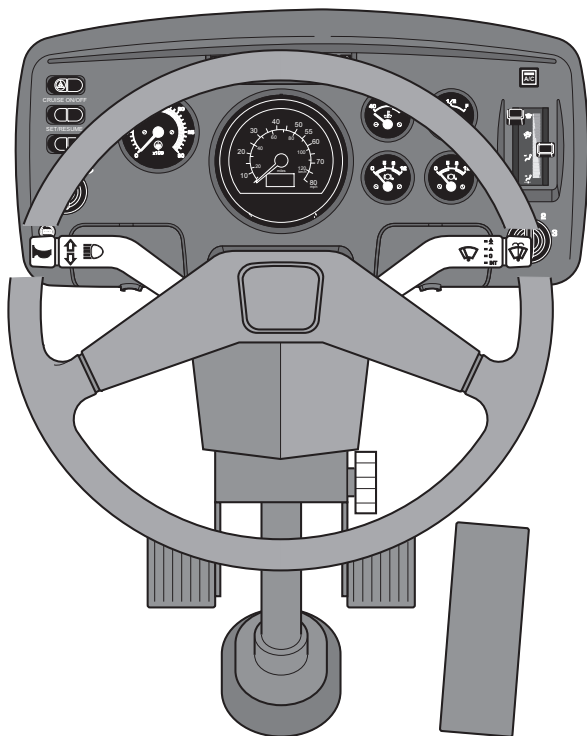

### Adjustable Steering Column



**WARNING!** Do not adjust the steering column while the vehicle is in motion, it could cause loss of control. You would not be able to steer properly and could have an accident. Make all adjustments to the steering column while the vehicle is stopped.

Loosen the locking control and move the steering wheel forward or rearward to the required position; ensure that the locking control is tightened and that the steering column is locked in position before attempting to drive the vehicle.

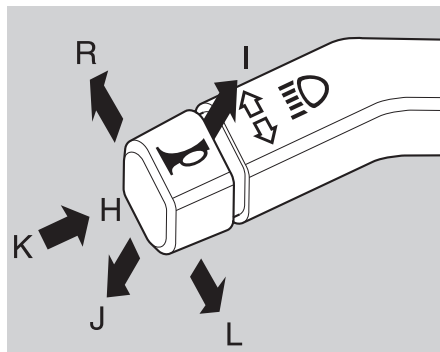

081140

#### Multi-function Switch, Left

##### Headlight flash, low beam, high beam

Position H: rest position.

Position I: lift against spring pressure = headlight flash.

Position J: position for switching between low beam or high beam.

The lever always returns to position H when it is released.

#### Turn Signals

The lane-change mode of the turn signals is operated by keeping the lever pushed in against spring pressure. The turn signals work only with the ignition switched on.

Position L: *turn signals, left*

Position H: *rest position*

Position R: *turn signals, right*

#### Horn

The horn works when button K is pushed in against spring pressure.

## Chassis

## Getting to Know Your Vehicle

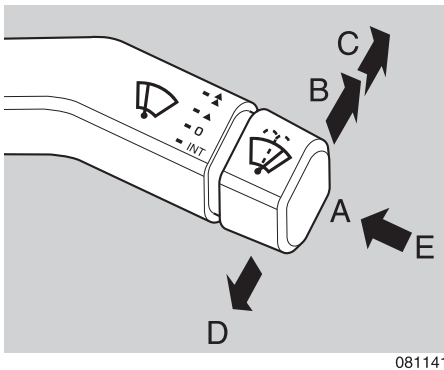

081141

**Multi-function Switch, Right****Windshield wipers**Position A: *wipers off.*Position B: *wipers on, normal speed.*Position C: *wipers on, high speed.*Position D: *single wipe and intermittent wipe function*

Momentarily depress the switch (up to ½ sec.) and then release to obtain a single wipe of the windshield. Depress the switch for between ½ to 1½ secs to activate the intermittent wipe function; depress the switch for ½ to 1½ secs to cancel the intermittent wipe mode.



**NOTE:** *A single wipe can be carried out between intermittent wipes without cancelling the intermittent wipe cycle.*

The windshield wipers work only with the ignition switched on.

**Windshield washers**

The windshield washers are activated by depressing button (E) against spring pressure.

The wipers simultaneously make three sweeps across the windshield.

**Chassis****Towing Pin**

The front bumper incorporates a towing pin which can be fitted to the left or right side of the bumper and is suitable for all normal towing. Refer to the “*Emergency Repairs*” section of this handbook for the recommended towing procedures.

## Daily and Weekly Maintenance

---

# **DAILY AND WEEKLY MAINTENANCE**

### **Driver's Check List**

To keep your truck in top shape and maintain a high level of safety for you, your passengers, and your load, make a thorough inspection every day before you drive. You will save maintenance time later, and the safety checks could help prevent a serious accident. Please remember, too, that the Federal law requires a pre-trip inspection per Federal Motor Carrier Safety Regulation 392.7 and so do commercial trucking companies.

You are not expected to become a professional mechanic. The purpose of your inspections is to find anything that might interfere with the safe and efficient transportation of yourself, any

passengers, and your load. If you do find something wrong and cannot fix it yourself, have an Authorized Service Center or qualified mechanic repair your vehicle right away.

The following operations are to be performed by the driver. Performing these checks and following the maintenance procedures in this manual will help keep your truck running properly.

### **Approaching Your Vehicle**

- Check the overall appearance and condition. Are windows, mirrors, and lights clean and unobstructed?
- Check beneath the vehicle. Are there signs of fuel, oil, or water leaks?

- Check for damaged, loose, or missing parts. Are there parts showing signs of excessive wear or lack of lubrication? Have a qualified mechanic examine any questionable items and repair them without delay.
- Check your load. Is it secured properly?

### **Daily Checks**

#### **Engine Compartment**

1. Engine Fluid Levels—add more if necessary.
  - Engine oil
  - Coolant (check while engine is cold)
  - Power steering fluid level

2. Engine Belt—check tension and condition of belts per engine manufacturer's Operation and Maintenance Manual.

- Measure the belt tension at the longest span of the belt.
- If cracks, breaks or tears are found in any belt, the belt should be replaced before operating the vehicle.

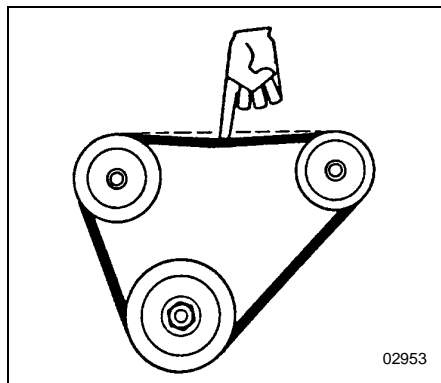

Tension Test

#### Retensioning New Belts

A belt is considered "used" after 30 minutes of operation. After running for an hour or more, new belts will loosen. Check for proper tension after the first period of operation. If the belt can be deflected 1/8 in. (3 mm) more than specified, tighten according to the instructions above.

## Daily and Weekly Maintenance



**CAUTION: Do not tighten belts beyond specified limits. Damage to bearings and belts may occur.**

3. Fuel Filter/Water Separator Draining—check and drain. Depending on the fuel storage facility, more frequent draining may be required.
4. Windshield washer reservoir fluid level—fill if necessary.

#### Chassis and Cab

Before entering the cab and operating the vehicle, check the following equipment for proper maintenance:

1. Lights—do headlights, turn signals, emergency flashers, and exterior lamps function and are they clean and adjusted properly?
2. Windows and Mirrors—are they clean and adjusted properly?



## Daily and Weekly Maintenance

---

3. Tires and Wheels—are they inflated properly? Are all wheel cap nuts in place and torqued properly—tighten if necessary. Check front wheel bearing oil levels. Inspect all tires and wheels for damage—correct if found.
4. Suspension—check for loose or missing fasteners. Check damage to springs or other suspension parts.
5. Brake Components—check lines, linkages, chambers, parking and service brake operation.
6. Air System—are there leaks?
  - Air Tanks—drain water from all air tanks. Make sure the drain cocks are closed.
7. Steps and Handholds—check for worn surfaces and loose or missing fasteners.
8. Fluid Tanks—check underneath the vehicle for signs of fluid leaks. If any are found, correct before operating the vehicle.
9. Fuel Tank Caps—are they secure?



**WARNING! Diesel fuel in the presence of an ignition source (such as a cigarette) could cause an explosion. You could be seriously injured. A mixture of gasoline or alcohol with diesel fuel increases this risk of explosion.**

- **Do not remove a fuel tank cap near an open flame.**
- **Use only the fuel and/or additives recommended for your engine.**

### Cab Interior

1. Seat—adjust the seat for easy reach of controls.
2. Seat Belts—fasten and adjust safety restraint belts.
3. Steering Column—adjust for easy reach.
4. Mirrors—check and readjust mirrors if necessary.
5. Lights—turn ignition key to the ON position and check for warning lights and buzzer. Check operation of turn signals and emergency lights.
6. Instruments—check all instruments.
7. Windshield—check operation of windshield wipers and washers.
8. Horn—check operation of horn.

## Daily Maintenance

9. Storage Compartment—all loose items stowed securely. Is the fire extinguisher fully charged? Is your road emergency kit complete? Compartments closed?
10. Fuel—check fuel. Is there enough fuel?



**NOTE:** *The above items (Engine Compartment, Chassis and Cab, and Prestart Checks) should be checked daily, as a minimum. They are in addition to, not in place of Federal Motor Carrier Safety Regulations. These regulations may be purchased by writing to:*

Superintendent of Documents  
 U.S. Government Printing Office  
 Washington, DC 20402

## Daily Maintenance Front Access Panel

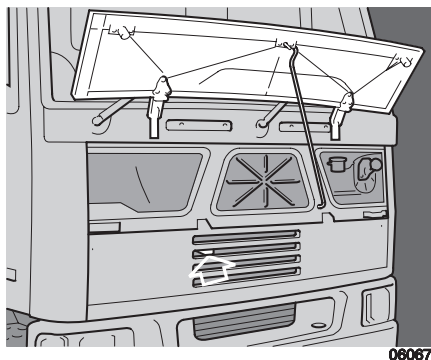

### To Open

The hinged front panel can be unlocked by pushing the release control sideways. The front access panel can then be swung up and secured in position with the support stay.

## Daily and Weekly Maintenance

### To Close

To close the front access panel, release and stow the support stay and lower the front panel into position. Gently push each lower corner of the front access panel until the internal locks are heard to engage.

### Engine Oil Level

1. The vehicle must be parked on flat and level ground.
2. Pull the dipstick (1) out of the dipstick tube and wipe it clean with a lint-free cloth.
3. Place the dipstick completely back in the dipstick tube.
4. Withdraw the dipstick again and check the oil level; the oil level should always be between the two marks on the dipstick.

## Daily and Weekly Maintenance

## Daily Maintenance

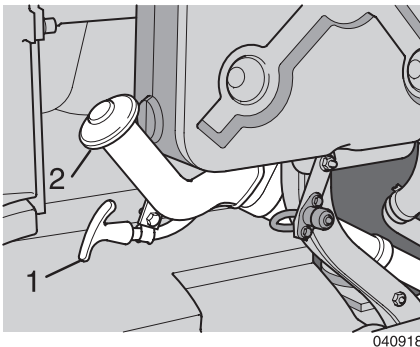

5. If necessary, add oil through the filler opening (2). Always use oil of the same brand and grade. Never overfill with oil!

**i** **NOTE:** Difference between the MAX and MIN marks on the dipstick is approximately 1 3/4 quarts (2 liters).

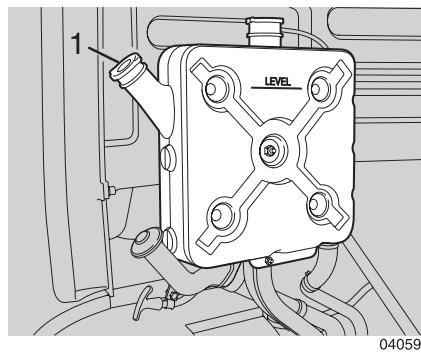

### Coolant Level



**WARNING!** Do not attempt to remove the surge tank filler cap while the engine is running or still hot. The complete cooling system is under pressure in these conditions. Scalding steam and fluid under pressure may escape and cause serious injuries. You could be badly burned.

**Before attempting to check the coolant level, ensure that the following safety instructions are observed:**

- Do not fill the cooling system through the pressure cap aperture.
- Do not attempt to fill a hot engine with cold coolant.
- Anti-freeze solutions contain toxic chemicals which must not be consumed or allowed to come into skin contact. Use impervious protective clothing and gloves when handling antifreeze. In the event of slight skin contact, thoroughly rinse the affected area with water. If there is excessive skin contact, ingestion, or inhalation seek medical advice immediately.

## Daily Maintenance

1. Remove the filler cap (1) and check that the engine coolant is level with the lower lip of the filler neck; if necessary, fill the surge tank with approved coolant.



**CAUTION:** *The use of unapproved coolants can cause severe damage to the cooling system and its components. Should the cooling system require an excessive amount of coolant, the complete system must be inspected for leaks and repaired (consult your dealer).*

## Wheels And Tires

Remove any stones or other foreign objects from the tire tread and from between the tires (axles fitted with dual wheels).

- Check for evidence of wear and damage and for nails or other foreign objects embedded in the tires.
- Check the wheel lug nuts.
- Check the tire pressures. Do this while the tires are cold.

## Daily and Weekly Maintenance

### Lighting And Instruments

- Check the vehicle lighting, stoplights, and instruments for correct operation.
- Also check the operation of the horn, windshield wipers, and washers.

### Driver's Seat And Mirrors

- Adjust the seat and mirrors to the correct position.

## Daily and Weekly Maintenance

## Weekly maintenance

### Weekly maintenance

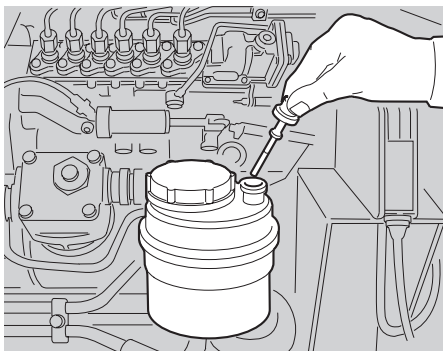

#### Power Steering Fluid Level



**WARNING!** Hydraulic fluid is a toxic substance which must not be consumed or allowed to come into skin contact.



**WARNING!** Ensure that the parking brake is on or all wheels are chocked prior to inspecting the power steering fluid level.



**NOTE:** Suitable wheel chocks are at a minimum an 18-inch (46 cm) long 4x4.



**CAUTION:** Do not operate the vehicle if the power steering fluid level is low.

1. Thoroughly clean the area around the dipstick.
2. Check the fluid level in the reservoir with the dipstick.
3. With the engine running, the fluid level should be up to the upper mark (MAX) on the dipstick. With the engine switched off the fluid level is approximately 3/4 inch (2 cm) higher.

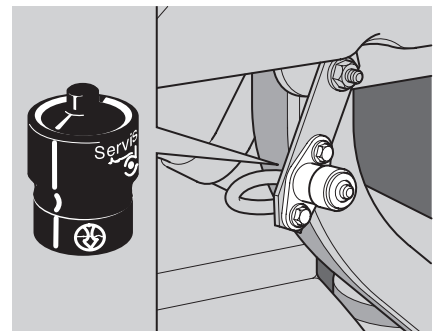

#### Air Filter Restriction Indicator

The air induction system is equipped with a vacuum operated restriction indicator. The air filter element **must** be replaced whenever the restriction indicator has been activated; this is indicated by the appearance of a red-colored plunger within the indicator body. For further information contact your dealer.

## Weekly maintenance

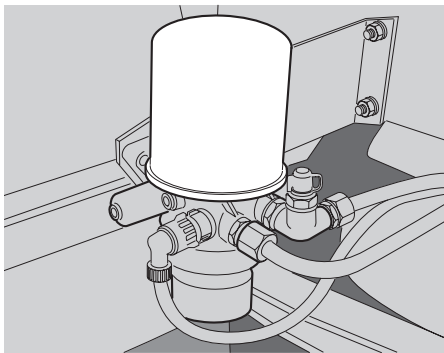

070387

### Brake System Air Dryer (optional equipment)

 **WARNING!** Do not operate the vehicle in the event of a malfunction in any air circuit. Such a malfunction may prevent the brake system from operating properly, and could result in an injury accident. The vehicle should not be operated until the sys-

*tem is repaired and both braking circuits, including all pneumatic and mechanical components, are working properly.*



**WARNING!** Ensure that the following safety instructions are strictly observed:

- Fully charged air reservoirs contain air at an approximate pressure of 120 psi (8.4 bar). It is essential that suitable eye protection and protective gloves are worn while releasing the air pressure from the reservoirs.
- The air dryer and filter cartridge contain pressurized air at the brake system operating pressure. Do not puncture nor attempt to remove the filter cartridge.

## Daily and Weekly Maintenance

1. Chock the road wheels and fully charge the vehicle air system.



**WARNING!** If the supply and service tanks are not drained at the recommended frequency, water could enter the air lines and valves. This could cause corrosion or blockage, which could compromise the brake system safety and potentially cause an injury accident.

2. Pull each air reservoir drain valve ring and check that the expelled air is free of any condensate (water/oil/particles); should any condensate be observed from any air reservoir consult your dealer.

## Daily and Weekly Maintenance

## Weekly maintenance

**Clutch Fluid Level**

**WARNING!** Hydraulic fluid is a toxic substance which must not be consumed or allowed to come into skin contact.

1. Open the cab front panel to gain access to the clutch reservoir.
2. Check that the hydraulic fluid level registers on or above the level mark (5), molded on the clutch reservoir; if necessary, fill the fluid level as follows:
  - Remove the reservoir cap (1) and extract the rubber diaphragm (3) from the reservoir (4).
  - Fill the reservoir with clean hydraulic fluid of the approved specification (DOT 3 brake fluid).

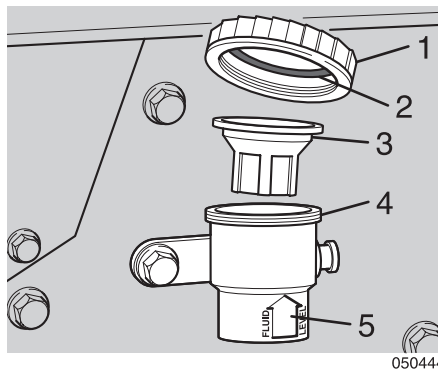

**CAUTION:** Should the clutch fluid reservoir require an excessive amount of hydraulic fluid, the complete system must be inspected for leaks and repaired if necessary (consult your dealer).



**CAUTION:** Do not allow the clutch hydraulic fluid to contact paint finished surfaces. It could damage the paint.

- Insert the rubber diaphragm into the reservoir.
- To prevent leakage from the reservoir, ensure that the seal (2) in the reservoir cap is in good condition before refitting the cap.

## Weekly maintenance

## Daily and Weekly Maintenance

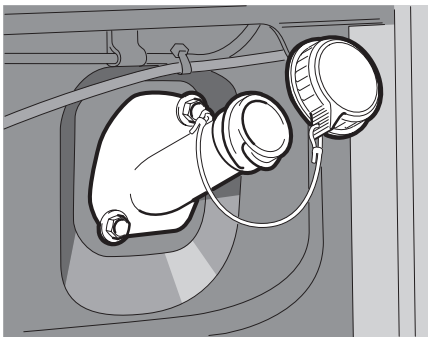

060622

### Windshield Washer Fluid Level

1. Open the cab front panel to access the reservoir filler tube.
2. Remove the filler cap and refill the reservoir with a suitable windshield cleaning solution.



*NOTE: During the winter period, it is recommended that a suitable solution with anti-freeze protection is used.*

### Tires

- Check the tread depth of the tires.
- Check that the wear pattern is evenly distributed over the running surface of each tire.



## DRIVING

### General

**Before starting the engine or setting out on a trip, always check:**

- The vehicle for water, fuel, or oil leaks.
- The seat and mirrors for correct positioning.
- The operation of the lights and instruments.
- That the vehicle load is correctly secured.

**After each trip always check that:**

- The doors of the vehicle are locked.
- The load is still properly secured.

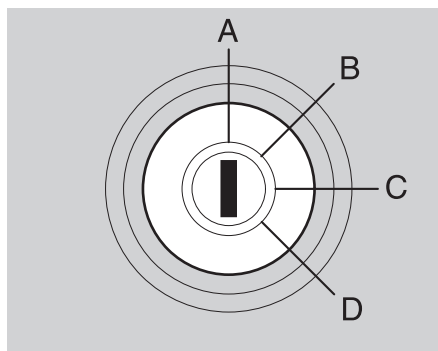

08049:

### Ignition Switch



**WARNING! Do NOT remove the key from the steering lock/ignition and starter**

**switch while the vehicle is in motion because this may cause the steering wheel lock to engage.**

#### **Position A: rest position**

The key can be removed. When the key is removed from the switch, the steering wheel is locked.

#### **Position B: accessories position**

Steering wheel unlocked. The key cannot be removed. Accessories, such as a radio, can be switched on.

#### **Position C: ON position**

All power consumers can be switched on.

#### **Position D: starting**

When the key is released, it automatically returns to position C.

## Starting Procedure



**WARNING!** Ensure that the following safety instructions are strictly observed:

- Do not start the engine in a confined space or unventilated area. Exhaust fumes contain toxic gases which, if inhaled, can prove fatal.
- Before driving away, ensure that all warning lights have been extinguished and the warning buzzer has ceased to sound.



**CAUTION:** When the engine starts and runs, do not allow the engine to exceed its idling speed for 10 seconds; this procedure will ensure

*that adequate oil pressure is available at the turbocharger bearings.*

1. Ensure that the parking brake is applied and the shift lever is in the neutral position.
2. Turn ignition key to position 'C' and check that the oil pressure and parking brake warning lights illuminate and that the fuel gauge shows sufficient fuel for the trip.
3. If the engine WAIT light is on, wait until it goes out.
4. With the accelerator pedal released, turn the ignition key to position D; release the key immediately after the engine has started. If the engine fails to start after 10 seconds, release the key. Wait 10 seconds and repeat the starting procedure.

## Operating the Transmission

### Introduction

Your is equipped with either a manual, automatic, or automated manual transmission with special features and gearing to meet your particular needs. It is important for you, the driver, to understand how your particular transmission is operated.

In addition to the instructions listed in this *Operator's Manual*, additional instructions and guidelines are available in the transmission manufacturer's *Driver/Operator's Instruction Manual* in your glovebox. Read the general guidelines and instructions that follow and

read the specific instructions contained in the transmission manufacturer's *Driver/Operator's Instruction Manual*.

## Operating Manual Transmissions

If your truck has an automatic transmission, go to page [62](#).

If your truck has an automated manual transmission, such as the Eaton® Auto-shift™, go to page [63](#).

Your transmission has six forward gears with full synchromesh engagement, and one reverse gear. You will find a shift pattern diagram on the gearshift knob. Make sure you follow the correct sequence for shifting your transmission.

## Transmission Warm-Up

In cold weather [below 32°F (0°C)], you may find shifting sluggish when you first start up. Transmission warm-up is especially important at this time, but it is always a good idea to warm your transmission oil before starting out on the road.

To warm the transmission lubricating oil during engine warm-up:

1. Put the transmission in Neutral.
2. Release the clutch pedal and let the transmission operate in Neutral for three to five minutes prior to shifting into either a forward or reverse range.

## Putting the Vehicle in Motion



**WARNING!** *Never drive your vehicle with the parking brake applied. Always release the parking brakes prior to moving the vehicle. Failure to disengage the parking brakes prior to moving your vehicle could result in excessive heat build-up in the brake system, resulting in a fire.*



**NOTE:** *Today's diesel electronic engines have significant torque and startability power at low RPM. Combinations of engine speed and available torque may over-power the vehicle's parking brakes.*



**CAUTION: Always use first gear or a low speed range to start the vehicle in motion. The use of a higher gear or speed range forces undue strain on the engine, clutch, other transmission components, and may cause damage.**

After making sure the vehicle's oil and air pressure are correct and all other parts and systems are in proper working condition:

1. Fully depress the clutch pedal and shift the transmission into first gear.
2. Lift the sleeve on the parking brake handle and push the handle fully forward to release the brakes.
3. Release the clutch pedal, then gradually accelerate.
4. Do not allow your vehicle to roll (even a little) in the opposite direction during clutch engagement. If

you need to start up on an incline, apply your service brakes before you release the parking brake. Then release your service brakes as you engage the clutch and apply throttle.

For further instructions on operating your transmission, see the transmission manufacturer's *Driver/Operator's Instruction Manual*.

If you have a misaligned gear condition in your vehicle's transmission and cannot start, gradually release the clutch, allowing the drive gear teeth to line up properly. Then the drive gear can roll enough to allow the teeth to line up properly and complete the shift.

The best engine performance and maximum economy is obtained if gears are properly selected. This efficiency is achieved by always selecting gears

within optimum engine rpm, which is where maximum torque and power are obtained.

### Shifting Gears in a New Vehicle

Shift carefully in a new vehicle. The transmission may be a little stiff at first. Avoid gear clashing by closely following these procedures.

When you are operating a new vehicle or one that has been exposed to cold weather, you want the transmission lubricant (fluid) to circulate and coat the contacting surfaces of the gears. Metal contacting metal in moving parts may seriously damage your transmission—do not drive in one gear for long periods of time until the transmission lubricant has a chance to coat all contacting surfaces.



***WARNING! Do not coast with the transmission in neutral or with the clutch pedal depressed—it is a dangerous practice. Without the use of the retarding power of the drivetrain, your vehicle can reach dangerous speeds. At very high speeds you may not be able to put the transmission in any gear. At high speeds you could seriously damage your vehicle or cause an accident when you put the transmission in gear. The engine speed could exceed the maximum governed speed and cause a serious accident due to mechanical failures.***

## More Transmission Tips

### “Riding” the Clutch

The clutch is not a footrest. DO NOT DRIVE WITH YOUR FOOT RESTING ON THE CLUTCH PEDAL. It will allow your clutch to slip, causing excessive heat and wear—damage could result.

### Release Bearing Wear

When you must idle your engine for any period of time, shift your transmission to Neutral and disengage the clutch (take your foot OFF of the pedal). This helps prevent unnecessary wear to your clutch release bearing, and it is less tiring for you, too.

## Clutch Adjustment

If your truck has an Eaton® Solo clutch, no adjustments are necessary. This is a self-adjusting clutch and requires no adjustments for wear.

Inspect manual clutches according to the maintenance and lubrication intervals in this manual. Regular maintenance must be followed to maintain correct clutch adjustment. Have your dealer's Service Department perform any adjustment necessary.

## Tips for Manual Transmission Operation

- Always use the clutch when making upshifts or downshifts.
- Always start in first gear.
- Never downshift when the vehicle is moving too fast.

## Operating the Transmission

Driving

- Never slam or jerk the shift lever to complete gear engagement.
- Never coast with the transmission in Neutral and the clutch disengaged.
- To provide smooth gear engagements while shifting, use proper coordination between shift lever and clutch.

### Operating Automatic Transmissions

An automatic transmission makes shifting much easier, of course. But because your truck pulls a heavy load, it is important to use it efficiently. For correct automatic transmission operation, also see the transmission manufacturer's *Operator's Manual*.

- On most automatic transmissions there is no "PARK" position, so you will need to apply the parking brake before leaving the cab. See [page 66](#).



**WARNING!** Do not leave the cab without applying the parking brake. The truck could roll and cause an injury accident. Always apply the parking brake before you leave the cab.

#### The MD Automatic Transmission

The MD (electronic) Series of transmissions have four, five, or six forward speeds, a Neutral position, and one reverse speed. Pressing the appropriate button selects the desired gear.

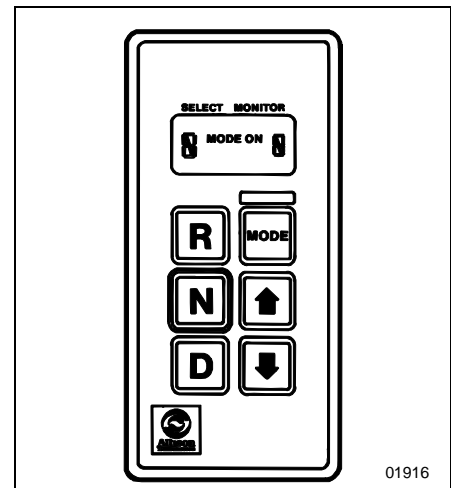

MD Automatic Transmission - Electronic Shift Selector

Vehicles equipped with the MD transmissions have various diagnostic features. Refer to the transmission manufacturer's *Operator's Manual* for information on all diagnostic features.

## Operating the Transmission

Driving

The MD transmission is programmed to restrict full operation until specific temperatures are reached. See the transmission manufacturer's *Operator's Manual* for details.

### Operating Automated Manual Transmissions

The Eaton® Autoshift™ transmission is an automated manual transmission. The Autoshift™ is a partially automated Eaton® Fuller® Roadranger® transmission that automatically selects and engages the transmission's gears. The driver must use the clutch to start and stop the vehicle, but not for shifting through the gears. A shift begins when

the Autoshift™ computer detects that conditions are right for a shift. The transmission signals the engine controller to break driveline torque and provides engine RPM for synchronizing the next gear. When engine speed and gear speed are synchronized the transmission engages the next gear and signals the engine to resume operation. Please see the transmission *Operator's Manual* for further details on the transmission's operation and components.



**WARNING! Do not leave the cab without applying the parking brake. The truck could roll and cause an injury accident. Always apply the parking brake before you leave the cab.**

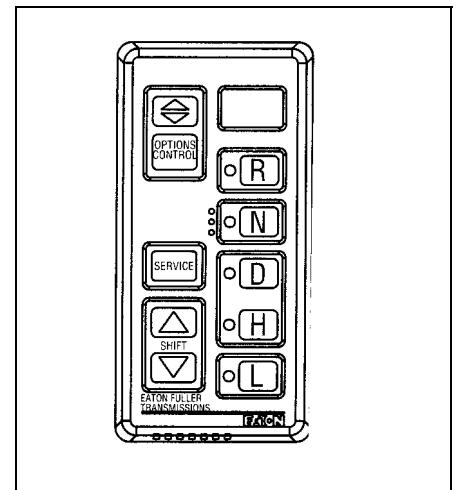

Eaton® Autoshift™ Transmission -  
Electronic Shift Selector

## Cruise Control

This feature improves fuel mileage and reduces driver fatigue by maintaining a constant vehicle speed. The cruise control will only operate above a programmed minimum vehicle speed of 30 mph for the Cummins ISB engine.

### Engaging the Cruise Control



**NOTE:** Ensure that the vehicle speed is above the minimum cruise control speed and the engine speed is above 1100 rpm.

1. Move the ON/OFF switch to the ON position.

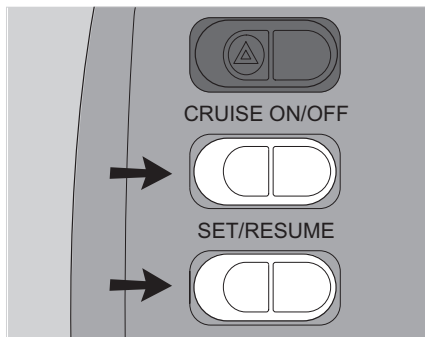

081175A



**NOTE:** Toggling the SET/RESUME switch to the RESUME position at this point will select the previously set cruise speed.

2. Accelerate the vehicle to the desired cruise speed.
3. Toggle the SET/RESUME switch to the SET position to set the cruise speed.

- To **decrease** the cruise set speed, hold the SET/RESUME switch in the SET position and coast to a lower speed.
- To **increase** the cruise set speed, hold the SET/RESUME switch in the RESUME position; this will accelerate the vehicle to a higher speed.

### Disengaging the Cruise Control

Do **one** of these steps to disengage the cruise control:

- Move the ON/OFF switch to the OFF position.

or

- Depress the brake pedal.

or

- Depress the clutch pedal.



### Reengaging the Cruise Control

1. Move the ON/OFF switch to the ON position.
- or
2. Toggle the SET/RESUME switch to the RESUME position.

### Steering

The steering gear is hydraulically assisted. As excessive pressure may damage the hydraulic pump, stop turning the steering wheel when the wheels are at full lock or are blocked by an obstacle. Steering is also possible without power assistance, but this requires considerable effort.

### Brakes

#### Anti-Lock Braking System (ABS)

Your truck is equipped with an anti-lock braking system (ABS). The ABS reduces the possibility of wheel lock-up. If a wheel is about to lock during braking, the ABS will automatically adjust air pressure to the brake chambers on the appropriate wheel(s) to prevent wheel lock-up. The ABS is automatically turned on when the ignition switch is turned on.



**WARNING!** Do not rely on an anti-lock brake system that is functioning improperly. You could lose control of the vehicle resulting in a severe accident and personal injury. If your ABS lamp goes on while you are driving or stays on after the self-check, your anti-lock system might not be working. The ABS may not function in an emergency. You will still have conventional brakes, but not anti-lock brakes. If the lamp indicates a problem, have the ABS checked.



**CAUTION:** It is essential that the following driving procedures are observed:

- Do not abuse the ABS system by excessively harsh or delayed applications of the service brakes.

- **Do not adapt your normal driving style when driving a vehicle equipped with ABS. It is essential that the braking system is operated in a safe and conventional manner.**
- **ABS does not shorten the overall vehicle braking (stopping) distance.**
- **In the event of an ABS malfunction, the ABS will be automatically disengaged and the ABS warning light will illuminate. The conventional braking system will remain operative, but the vehicle must be driven with care and the fault repaired as soon as possible.**



*NOTE: The operation and function of the ABS warning lights are detailed in the “Instruments and controls” section of this handbook.*

### Service brakes

The service brakes are operated by the footbrake pedal. If the vehicle has been driven through water or subjected to high pressure washing, full braking power may not be available; dry the brakes by lightly applying the brakes while the vehicle is in motion.

If there is a malfunction in the service brake system, the parking brake can be used for emergency braking; do **not** continue a trip with a faulty service brake system.

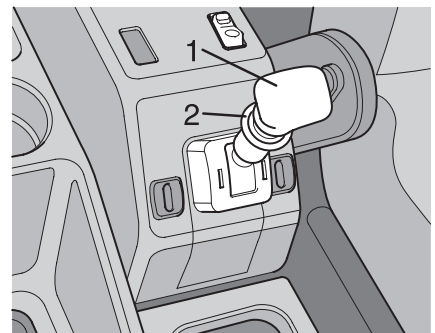

070578

### Parking brake / emergency brake



**WARNING! Do not attempt to release the parking brake while the steering lock is engaged; failure to observe this precaution can result in vehicle movement with the loss of steering control.**

## Brakes

## Driving

The parking brake control operates the spring brake actuators to apply the rear brakes on the vehicle.

Move the control lever (1) fully rearward to apply the parking brakes; a locking sleeve (2) will lock the control lever in position. To release the parking brake, lift the locking sleeve and move the control lever fully forward to the off position. A red warning light in the instrument panel will illuminate whenever the parking brake is applied; refer to the “*Instruments and controls*” section of this handbook.

In the event of a failure in the service brakes, the parking brake can be used as an emergency brake. Gradually move the parking brake control lever rearward to slowly apply the rear brakes on the vehicle. Braking effort will be proportional to the control lever movement.



**WARNING! Do not drive this vehicle with malfunctioning brakes. If one of the brake circuits should become inoperative, braking distances will increase substantially and handling characteristics while braking will be affected. You could lose control of your vehicle, be severely injured, or cause an accident. Have it towed to the nearest dealer or qualified workshop for repair.**

### Engine Exhaust Brake (option)

An engine exhaust brake may be installed (as an option) to create a braking effect on the drive wheels. This device uses your engine's power to slow your vehicle down. Because it can help keep your vehicle's brakes from overheating, it can save wear and tear

on the service brakes. However, the engine exhaust brake is not an emergency brake.

Ideally (on normal road surfaces), you should slow your vehicle with the engine exhaust brake (where permitted by law) and use the service brakes only for stopping completely. Operating this way will greatly prolong the life of the service brakes.



**WARNING! The service brakes must be used in an emergency. The engine exhaust brake alone might not stop you fast enough to prevent an accident. You could be badly hurt if you relied only on the engine exhaust brake.**

- **The engine exhaust brake is NOT intended as the primary brake for the vehicle, nor is it an emergency brake. The engine**

***exhaust brake only helps the service brakes by using pressure to slow the drivetrain. Use the service brakes for quick stops.***

### Exhaust Brake Operation

With the exhaust brake switch ON, the engine exhaust brake automatically creates its braking effect when you remove your foot from the accelerator pedal and all other required conditions are met (see below).

The brake switch is located on the switch panel between the seats. It controls whether the brake is ON (ready to slow the vehicle down) or OFF (no braking action).

- Make sure the exhaust brake switch is OFF before starting the engine.

- After the engine is started, warmed up, and you are ready to get under way, turn the exhaust brake switch ON for added braking effect.

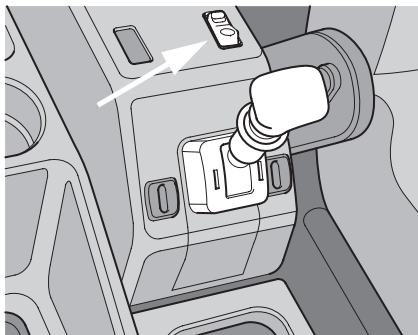

The engine exhaust brake activates if **all** of the following conditions are true:

- 0% throttle
- Clutch pedal is not depressed
- PTO and cruise control are inactive

- Engine speed is greater than 1000 rpm



***WARNING! Do not use the engine exhaust brake when operating on road surfaces with poor traction (such as wet, icy, or snow covered roads or gravel). The engine exhaust brake can cause the wheels to skid on a slippery surface. You could lose control of the vehicle and/or jackknife if the wheels begin to skid, resulting in an accident.***

Your vehicle is equipped with Rockwell/WABCO anti-lock brakes (ABS) and the operation of the engine exhaust brake (if turned ON) will be controlled by the ABS. For more ABS information, see [“Anti-Lock Braking System \(ABS\)” on page 65.](#)

## Stopping

## Driving

### Stopping

#### Parking

When the vehicle is parked on a grade, one or more of the following precautions should also be taken:

- Chock the wheels at front and rear.



**NOTE:** Suitable wheel chocks are at a minimum an 18-inch (46 cm) long 4x4.

- Angle the front wheels so that the vehicle will not move into the traffic stream if it is accidentally set in motion.

Apply the parking brake with the parking brake lever. Check that all the windows and the roof vent are closed. Turn off the ignition and remove the key. Then lock all the doors of the vehicle.

#### Turning off the engine



**WARNING! Do not remove the ignition key nor turn off the engine while the vehicle is in motion. Failure to observe this precaution can result in steering lock engagement.**

With the vehicle stationary, apply the parking brake and place the shift lever in Neutral. Before stopping the engine, allow it to idle for one to two minutes. This will allow the following:

- An adequate oil supply to the turbo-charger bearings while the turbo-charger rotor assembly is cooling preventing the possibility of turbo-charger bearing failure.
- Prevention of excessive engine coolant temperatures.

Turn the engine off by turning the ignition key to the OFF position. Then remove the key.

## Diesel Fuel

### Cold Weather Recommendations

When diesel fuel is subjected to low temperatures (below 21°F or -6°C), paraffin wax particulates will form within the fuel which will eventually create blockages in the fuel system. To minimize the risk of fuel *'waxing'*, it is recommended that the following precautions are observed:

- The use of winter grade fuel will give added protection to the fuel system during cold weather conditions. Ensure that the vehicle is using winter grade fuel in anticipation of cold weather conditions.
- In the event of the fuel waxing, it is recommended that a replacement fuel filter is carried to enable a blocked filter to be replaced; wax particulates cannot be dissolved by the application of heat.
- For extreme and prolonged cold weather conditions, it is recommended that the vehicle be equipped with a heated fuel filter and that all fuel pipes and fuel tanks are adequately insulated; refer to your dealer for further information.

---

## **PERIODICAL MAINTENANCE**

### **General**

The durability, safety, trade-in value, and reliability of your vehicle largely depends on the care you give it. This includes regular servicing in accordance with the maintenance schedules specified here.

The driving style of the crew members and how they care for the vehicle have a direct influence on the condition of the vehicle. The driver can frequently give the dealer information which is very important for correct maintenance.

The maintenance intervals stated in the Maintenance Schedule are based on the oil specifications stated in [“Recommended Lubrication Types” on page 86](#).

General

Periodical maintenance

**Maintenance and Lubrication Intervals**

normal pick-up and delivery operations. For all other applications, see your dealer for intervals.



*NOTE: Different lubricants or service intervals than those listed below may be required.*

Table 1, "Recommended Maintenance Intervals", shows service intervals for

**Table 1** Recommended Maintenance Intervals

ITEM	MILEAGE INTERVAL (miles) / TIME INTERVAL (Which-ever Occurs First)	COMMENTS
Engine Lubricating Oil -Check Fluid Level		See Engine Manufacturer's Specifications and Recommendations
-Change Oil, Oil Filter		Per Engine Manufacturer's Specifications and Recommendations
Clutch Inspect and Adjust Per Manufacturer's Specifications	7500 / 3 mos	w/ Eaton SAS 1401 Clutch
Clutch Release Bearing	7500 / 3 mos	
Clutch Cross Shaft	7500 / 3 mos	
Drivelines: City applications #	7500 / 3 mos	Grease Yokes and Slip Splines if lubrication zerks are provided
On-Highway applications##	15,000 / 3 mos	Grease Yokes and Slip Splines if lubrication zerks are provided



## General

## Periodical maintenance

**Table 1** Recommended Maintenance Intervals

ITEM	MILEAGE INTERVAL (miles) /TIME INTERVAL (Which- ever Occurs First)	COMMENTS
HVAC Filter Inspect and Clean as necessary per this manual	7500 / 3 mos	Clean the filter regularly with low pressure air. See <a href="#">page 37</a> . Replace HVAC Filter Annually
Inspect Front Axle Fluid Level *	7500 / 3 mos	
Inspect Transmission Fluid Level *	7500 / 3 mos	Inspect Fluid Level per Manufacturer's Recommended Procedures
Inspect Rear Axle Fluid Level *	7500 / 3 mos	Inspect Fluid Level per Manufacturer's Recommended Procedures
Inspect all Brake Components, replace per Manufacturers Recommendations	7500 / 3 mos	
Inspect Engine Air Filter	7500 / 3 mos	Have Filter Element Cleaned, as required via Restriction Indicator, at a Certified PACCAR Dealership, Replace Filter Element Annually
Front and Rear Brake Camshafts	15,000 / 6 mos	
Front and Rear Brake Autoslack Adjusters	15,000 / 6 mos	
Front Axle Kingpins, Tie Rod Ends	15,000 / 6 mos	
Replace Power Steering Fluid and Filter	15,000 / 6 mos	Twice Yearly ( After Summer and Winter )
Steering Column Shaft U-joint	15,000 / 6 mos	

General

Periodical maintenance

**Table 1** Recommended Maintenance Intervals

ITEM	MILEAGE INTERVAL (miles) / TIME INTERVAL (Which-ever Occurs First)	COMMENTS
Steering Shaft Telescopic Slide Surfaces	15,000 / 6 mos	
Door Hinges, Latches, and Striker Plate	15,000 / 6 mos	
Test Coolant for Freeze Point and Nitrite Levels with 2-Way Test Strip	15,000 / 6 mos	Maintain as Indicated by Test Strip Replace Coolant annually
Front Axle Fluid Replace *	Perform at brake lining replacement	Per Manufacturer's Specifications and Recommendations
Inspect and Adjust Per TMC RP618 Guidelines		
-Front Wheel Bearings	30,000 / Annually	
-Rear Wheel Bearings	30,000 / Annually	
Lock Cylinders	30,000 or As Required	
Door Weatherstrip	30,000 or As Required	
Transmission Fluid Replace *	250,000 / 3 yrs	
Rear Axle Fluid Replace *	250,000 / 3 yrs	
# City applications are defined as all applications that require a minimum of 90% of operation time within city limits.		
## On-Highway applications are defined as all applications requiring less than 10% of operating time on gravel, dirt or unpaved roads.		
* Use only synthetic fluid Per Manufacturers Specifications and Recommendations		

General

Periodical maintenance

**Maintenance Schedule**

Use Table 2, "Maintenance Schedule," as a guide to plan service work. Be sure and follow the frequency recommendations for your vehicle. Also refer to engine manufacturer's maintenance guidelines.

**TABLE KEY**

<b>i</b>	<i>NOTE: If a scheduled service interval is shaded, skip to the next interval..</i>
I	Inspect and Service as required
R	Replace
G2	Synthetic Lube Required

**Table 2** Maintenance Schedule

OPERATION \ FREQUENCY	INTERVAL					COMMENTS
	7,500 mi 12,000 km	15,000 mi 24,000 km	30,000 mi 48,000 km	60,000 mi 96,000 km		
INITIAL DRIVE-IN	A	B	C	D		
Clutch Inspect and Adjust per mfr's instructions	I					
Glass for Cracks or Chips	I					
Door Window Operation			I			
Radio		I				
Interior Lights	I				Replace As Required	
Interior Appearance / Condition:					Check For Tears, Stains, Wear	
Seats	I					
Floor Mats	I					
Door Panels	I					
Headliner	I					
Dash	I					
Covers	I					

General

Periodical maintenance

**Table 2** Maintenance Schedule

Wiper Operation					
Wiper Blade Condition					Replace As Required
Horns (Electric and Air) - Operation					
Mirrors - Cracks or Mounting					
<b>SAFETY EQUIPMENT</b>	<b>A</b>	<b>B</b>	<b>C</b>	<b>D</b>	
Drain Water from Air Tanks					
Air Tank Check Valve					
Emergency Operation of Spring Brakes					
Air Press. Build-up time:					
Governed Air Pressure:					
Air Press. Drop-Brakes not Applied: ____					
Air Press. Drop-Brakes Applied: ____					
Fire Extinguisher Charge					Replace or Recharge Per Extinguisher Manufacturer Recommendation
Flare Kit / Reflectors					
<b>CIRCLE INSPECTION</b>	<b>A</b>	<b>B</b>	<b>C</b>	<b>D</b>	
Physical Damage:					
Exterior Sheet Metal					
Grille and Radiator					
Air Lines					
Headlights - High and Low Beams					
Road Lights					
Marker Lights					
Turn Signals					
Emergency Flasher					
Brake Lights					
Backup/Loading Lights					
License Plates: Permits and Mounting					
Mud Flaps / Serviceable					
Fuel Tank Mounting					Check Fastener Torque And Condition Of Rubber Lining
Exhaust System-Condition and Mounting Bolts					Leaks / Corrosion

General

Periodical maintenance

**Table 2** Maintenance Schedule

Frame Fastener Torque:		I			
Cab: Hold-down Latches			I		
Mounts			I		
Front Pivot Assembly		I			
Jack Operation and Leaks		I			
<b>ENGINE SERVICE</b>	<b>A</b>	<b>B</b>	<b>C</b>	<b>D</b>	
Cooling: Test Coolant for Freeze Point and Nitrite Level w/2-way Test Strip		I			Maintain Coolant as Indicated by Test Strips Replace Coolant Annually
Coolant Level	I				
Coolant Protection: _____ degrees		I			
Pressure Test					Check At Time Of Coolant Replacement
Hose Condition and Connections	I				Leaks And Cracking
Radiator Mounting	I				Check Rubber Bushings
Fan Shroud		I			Check For Damage
Fan Assembly and Idler Pulley		I			Check For Cracks, Chips; Check Belt Tensioner Bearing
Check Water Pump for Leaks / Play			I		
Radiator – Exterior Condition			I		
Air Cleaner:		I			Replace Annually / Air Cleaner Restriction: Replace If Restriction Indicator displays service required
Contaminant Accumulation					Check Every 7,500 Miles (12,000 km) In Dirty Conditions
Vacuator Valve–Operation & Condition	I				
Mounting Bolts and Clamps		I			
Interference		I			
Power Steering Fluid and Filter– Replace		R			Service 2 Times Per Year (after summer and winter)
Drive Belt Condition and Adjustment	I				Per Engine Manufacturer's recommendations
Air Conditioner Compressor Mounting	I				
Cold Start Aids		I			
High Idle: _____ rpm				I	
Emergency Shutdown		I			
Vibration Damper Condition		I			

General

Periodical maintenance

**Table 2** Maintenance Schedule

Drain Water from Fuel System	I				Per Engine Manufacturer Requirements
Engine Oil – Change					Per Engine Manufacturer Requirements
Oil Filters – Replace					Per Engine Manufacturer Requirements
Fuel Filters – Replace		R			
Cranking System:					
Visual Inspect./Loose Connections	I				
Alternator/Charging System:					
Visual Inspection/Loose Connections	I				
<b>UNDER VEHICLE</b>	<b>A</b>	<b>B</b>	<b>C</b>	<b>D</b>	
Steering Components – Condition:	I				
Steering Gear		I			
Steering Shaft Splines and Joint(s)	I				
Pitman Arm		I			
Drag Link		I			
Steering Arms		I			
Tie Rod Arms		I			
Tie Rod Ends		I			
Radius Rods / Torque Arms		I			
Chassis Frame – Cracks or Breaks	I				
Spring Shackles and Hanger Brackets		I			Check For Cracks    Check Fastener Torque
Spring Pins		I			
King Pin Wear			I		Per Manufacturer's Specification
Steer Axle Wheel Bearing End Play Inspection			I		With LMS Outer Ends 350,000 Miles • No Leak – No Service
Front Hub Lubricant Level	I				
Spring Leaves			I		
U-Bolt and Suspension Fastener Torque			I		Tighten U-bolts after the first 500 miles (800 km). Rear suspension fasteners: retorque after first 2,000 miles (3218 km).

General

Periodical maintenance

**Table 2** Maintenance Schedule

Leaks:					
Coolant					
Engine Oil					
Power Steering					
Fuel					
Transmission					
Axles					
Inner and Outer Hub Seals					
Engine and Transmission Mounts					Check Rubber Bushings for Cracks And Condition
Transmission Lubricant Level - Check					Inspect Fluid Level per Manufacturer's Recommended Procedures
Drivelines – U–joints and Slip Yokes - Check					
Rear Axle Lubricant Level - Check					Inspect Fluid Level per Manufacturer's Recommended Procedures
Rear Axle Lubricant Replace					Replace per <a href="#">"Recommended Maintenance Intervals" on page 72</a>
Rear Axle Breathers – Clear					
Inspect All Brake Component Condition					
Brake Chamber Mounting Bolt Torque					
Brake Hoses for Cracks and Chafing					
Clutch Pedal Shaft - Worn or Loose					
Clutch Linkage - Worn or Loose					
Clutch Adjust					Per manufacturer's specifications
Driveline Center Bearing					
Automatic Slack Adjusters					

General

Periodical maintenance

**Table 2** Maintenance Schedule

Brakes: Lining Remaining (replace as required)		I			
RF _____ RRF _____ RRR _____					
LF _____ LRF _____ LRR _____					
Drum Condition:		I			
RF _____ RRF _____ RRR _____					
LF _____ LRF _____ LRR _____					
<b>BATTERIES</b>	<b>A</b>	<b>B</b>	<b>C</b>	<b>D</b>	
Signs of Over-Charging			I		Check As Required
Remove Corrosion and Seal Terminals		I			Clean As Required
Hold-down and Box – Mounting Bolt Tight			I		
Battery Cables - Chafing and Protective Coating		I			
(Color of charge indicator for each battery)			I		
1 _____ 2 _____ 3 _____ 4 _____					



General

Periodical maintenance

**Table 2** Maintenance Schedule

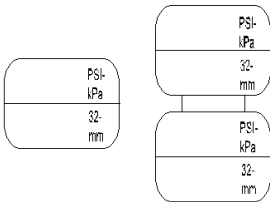
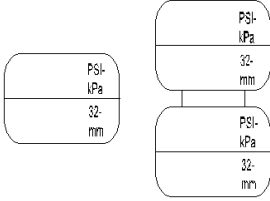
<b>TIRES AND WHEELS</b>	<b>A</b>	<b>B</b>	<b>C</b>	<b>D</b>
Missing Valve Caps and Stem Locks				
Cracks or Loose Wheel lugs				
Irregular Wear				
Tire Pressure (Record below)				
Remaining Tread (Record below)				
Tires & Wheels Inspection				
Right 				
Left 				
Air Pressure Adjusted to: _____				

General

Periodical maintenance

**Table 2** Maintenance Schedule

<b>ALIGNMENT</b>	<b>A</b>	<b>B</b>	<b>C</b>	<b>D</b>
Toe-in: _____ in (mm)				
Caster: L _____ R _____				
<b>ROAD TEST</b>	<b>A</b>	<b>B</b>	<b>C</b>	
Steering / Steering Play				
Shifting				
Brakes				
Engine Operation (noises, surging, black smoke)				
Seat Belts				
Seat Adjustment Operation				
Cab Heater				
Air Conditioner - Performance and Condition				
Instruments and Gauges:				
Speedometer/odometer				
Tachometer				
Oil Pressure				
Engine Temperature				
Illumination				
ABS Warning				
Low Brake Pressure Warning Devices				

## General

### Lubrication Specifications

You will find a complete Engine Lubrication Service Guide in the *Engine Operation and Maintenance Manual*. There, the engine manufacturer explains more fully all the maintenance operations you and a qualified service mechanic will need. And please remember: one key to keeping your vehicle running at top performance and in prolonging its life is proper lubrication servicing. Neglecting this essential aspect of vehicle care can cost time and money in the long run.

Below you will find basic information needed to perform routine vehicle lubrication. Of course you will want to schedule service more frequently if you are operating under severe conditions such as extreme heat or cold, with very heavy loads, rough roads, etc. For any special service requirements, consult your service manuals and your lubricant supplier. The component manufacturer's specification and requirements take precedence over other specifications.

## Periodical maintenance



**CAUTION:** Handle lubricants carefully. Vehicle lubricants (oil and grease) can be poisonous and cause sickness. They can also damage the paint on the vehicle.



**CAUTION:** Do not mix different types of lubricants. Mixing lubricants (oil and grease) of different brands or types could damage vehicle components; therefore, drain (or remove) old lubricants from the unit before refilling it.

- When switching between types of lubricants, thoroughly drain all areas of the component.

**Lubrication Types**

Use Table 4 on page 86 and the list of lubricants below to identify the type of lubricant to use on your vehicle.

- BB:** Ball Bearing grease
- CB:** Engine oil for mild to moderate requirements
- CC/CD:** Engine oil for severe requirements (MIL-L-2104B /MIL-L-45199B w/ 1.85% max sulfated ash content)
- CD:** Engine oil meeting API "Five engine test sequence"
- CE:** Engine oil meeting severe duty service requirements for direct-injection turbocharged engines.
- CL:** Multipurpose chassis grease
- EP:** Extreme Pressure lubricant
- GL:** Straight mineral gear lubricant, Grade 2
- HD:** Synthetic SAE 75W90
- HT:** High Temperature grease (Timken Specification 0-616)
- SD:** Engine oils with increased protection against temperature deposits, rust, wear, and corrosion.
- PS:** Chevron Torque Fluid, Dexron III, or Mercon

**Table 3** Lubricant Applications

APPLICATION	LUBRICANT
Universal Joints	EP
Drive Shaft Splines	CL
Wheel Bearings	HD
Steering Column	CL
Alternator Bearing	BB*
Fan Hub	BB*
Power Steering Reservoir	PS
Steering Drag Link	CL
Steering Knuckles	CL
Clutch Release Bearings	BB
Brake Shoe Anchor Pins	HT
Brake Cam Bearings	HT
Slack Adjusters	CL
Starter Bearings *	CC
Turbocharger Aneroid *	CC
Water Pump	BB*
*Consult manufacturer or lubricant supplier for special details.	



*NOTE: The responsibility for meeting these specifications, the quality of the product, and its performance in service rests with the lubricant supplier.*

## Oil Reservoirs

For oil reservoirs with side filler plugs (transmissions, rear axles, transfer cases, etc.), the oil must be level with the filler opening.

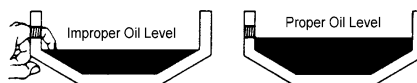

**NOTE:** Use care when checking the oil level with a finger. Just because you can reach the oil level with a finger, does not mean the oil level is correct.

## Lubrication Chart

The following lubrication specifications (see Table 4 on page 86) are for an ambient operating temperature range of  $-15$  to  $100^{\circ}\text{F}$  ( $-26$  to  $38^{\circ}\text{C}$ ). For extreme temperature operations, consult the component manufacturer's manuals.

**Table 4** Recommended Lubrication Types

COMPONENTS	RECOMMENDED LUBRICANT
Power Steering Gear	Chevron Torque Fluid C4, Dexron III, or Mercon
Driveline U-Joints Slip-Joint Splines Cab Pivots Clutch Pedal Shaft Other chassis grease fittings not covered below.	EP chassis grease, lithium 12-hydroxystearate or lithium complex base, NLGI 2.
Wheel Bearing-Non Driving Axles	OIL LUBRICATED: SAE 75W-90 synthetic oil
Threaded Pins & Bushings (e.g., spring pins & bushings)	EP grease, lithium 12-hydroxystearate or lithium complex base, NLGI 2, with 3% molybdenum additive: Mobil Grease Special (Mobil), Molygrease EP (Chevron), or equal.
Suspension Fittings (other than threaded pins & bushings)	EP chassis grease, lithium 12-hydroxystearate or lithium complex base, NLGI 2.
Steering Axle: Grease Fittings on Steering Arm; Tie Rod Ends; Drag Link; King Pins	EP chassis grease, lithium 12-hydroxystearate base, NLGI 2.
Clutch Release Bearing (remove inspection plate for access); Driveshaft Center Bearing	High temperature ball bearing grease. Chevron SRI Mobil Grease HP, Texaco Multifax 2, or equivalent.
Automatic Slack Adjusters; Wedge Brake Components; Disc Brake Caliper	High temperature EP grease; Texaco Thermotex EP-1, Shell Darina EP-1, Mobilith AW-1, Rockwell 0-616A, or equivalent.
Cam Brake Camshaft Splines; Disc Brake Shaft Splines and Slide Pin Retainers; Brake Clevis Pins	Antiseize type grease, Rockwell specification 0-637.
Deviations from the above list of lubricants should be based on specifications published in the component manufacturer's manuals or otherwise approved by the manufacturer.	

General

Periodical maintenance

**Table 4** Recommended Lubrication Types

COMPONENTS	RECOMMENDED LUBRICANT
Brake Camshaft Bushings	EP Chassis grease, lithium 12-hydroxystearate base, NLGI 2.  <i>CAUTION: Do not contaminate brake linings with grease.</i>
Steering Shaft Grease Fittings	EP chassis grease, lithium 12-hydroxystearate base, NLGI 2.
Brake Treadle Hinge and Roller	Engine oil
Lock Cylinders	Lock lubricant.
Door Hinges	Not required — Teflon bushings
Door Latches & Striker Plates.	Polyethylene grease stick.
Door Weatherstrip	Silicone lubricant.
Other Items	Use manufacturer's manuals.
Deviations from the above list of lubricants should be based on specifications published in the component manufacturer's manuals or otherwise approved by the manufacturer.	

## Maintenance in Special and Exceptional Operating Conditions

When the vehicle is operated under exceptional conditions, it is important to consult your local dealer as it may be necessary to change the service intervals to suit the operating conditions. The service intervals can be adapted, as necessary, in consultation with the local dealer to suit the appropriate operating conditions.

### First Service

The first service inspection should be carried out at 7500 miles (12,000 km) and no later than twelve weeks after the vehicle delivery date, whichever comes first.

## Cab Maintenance

In order to maintain the quality of the surface and paint finish during vehicle operation, regular maintenance must be carried out on the exposed areas of the cab.

To prevent the formation of rust in box-section areas and other hollow areas, the cab is double galvanized and waxed during production.

## Preventive Maintenance Before the Winter Season

### Checking the Anti-freeze Content



**WARNING!** Before attempting to check the anti-freeze ensure that the following safety instructions are observed:

- *Do not attempt to remove the surge tank filler cap while the engine is running or still hot.*
- *Do not fill/top off the cooling system through the pressure cap aperture.*
- *Do not attempt to fill/top off a hot engine with cold coolant.*
- *Anti-freeze solutions contain toxic chemicals which must not be consumed or allowed to come into skin contact. Use impervious protective clothing and gloves when handling antifreeze. In the event of slight skin contact, thoroughly rinse the affected area with water. If there is excessive skin contact, ingestion or inhalation seek medical advice immediately.*



## General



**NOTE:** All new vehicles are factory filled with a 50% anti-freeze solution which will give frost protection down to  $-34^{\circ}\text{F}$  ( $-36^{\circ}\text{C}$ ).



**CAUTION:** The use of anti-freeze that does not conform to the required specification can cause severe damage to the cooling system and its components.

**The anti-freeze mixture must remain in the cooling system during the summer months.**

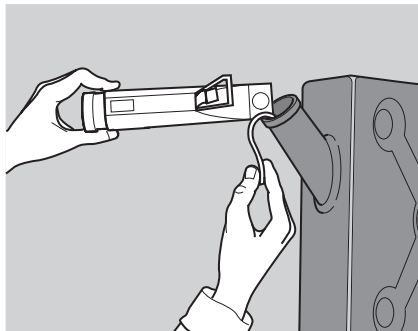

040553

1. Remove the filler cap from the surge tank.
2. Using 2-way test strips, perform freeze point and nitrite level tests per coolant supplier's recommendations. Supply additives and coolant/water mixture as indicated.



**CAUTION:** Damage to the engine and cooling system, such as corrosion and cavitation erosion, will occur unless antifreeze ZEREX PENRAY 2792 is used and maintained with supplemental coolant additive Pencool 3000 with Stabil-Aid. As needed, fill or top off the cooling system only with a ready-mixed clean water/ approved antifreeze solution using these products. The use of other antifreeze products will void your engine, radiator, and cooling system warranties.

3. The cooling system should be filled with ready-mixed clean water/antifreeze solution which conforms with the required specifications.



## Emergency repairs

# EMERGENCY REPAIRS

## Vehicle Tool Kit

All vehicles are equipped with an extension handle for tilting the cab. It is secured within the passenger's seat stowage compartment (twin seat) or, alternatively, secured behind the passenger's seat (single seat).

## Replacing The Drive Belt



**IMPORTANT:** Always install the correct replacement drive belt.

Refer to the engine manufacturer's Operation and Maintenance Manual.

## Drive belt tension

All engines are equipped with an automatic drive belt tensioner and, therefore, cannot be manually adjusted. In the event of incorrect drive belt tension, consult your dealer at the earliest opportunity.

## Replacing The Compressor Belt

(A/C and Compressor is optional)



**IMPORTANT:** Always install the correct replacement drive belt.

1. Disconnect the batteries, negative terminal first, then positive terminal.
2. Fully tilt the cab.

3. Loosen the adjusting screw retainer bolt (1), but do not remove.

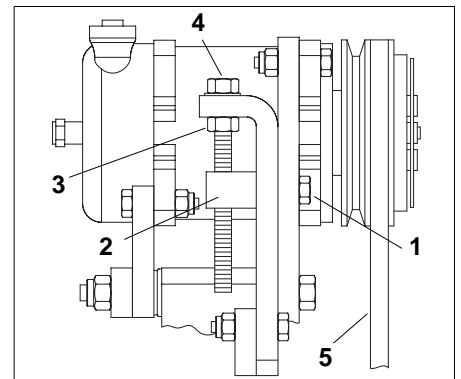

4. Loosen the jam nut (3).
5. Loosen the tensioning bolt (4).
6. Pivot the compressor to slacken the belt.
7. Remove the compressor belt (5).

8. Clean the pulleys and ensure that they are free of any contaminants (oil/fuel/dirt).
9. Install a new belt.
10. Pivot the compressor to tighten the belt and hold the tension by setting the adjustment screw. Torque the mounting screws to 17 to 23 lb. ft. (23 to 31 Nm).
11. Lower the cab and re-connect the batteries, positive terminal first.

## Replacing The Fuel Filter



**WARNING! Diesel fuel is flammable and must not be exposed to an open flame or other sources of heat such as a hot engine. Collect the escaping fuel in a suitable container.**

For detailed information, refer to the *Engine Operation and Maintenance Manual* provided.



**NOTE:** Small amounts of air introduced into the fuel system when refitting the filter cartridge will be vented automatically providing the filter cartridge has been filled with diesel fuel prior to installation.

## Adjusting The Brakes

Adjustment of the brake shoes is fully automatic.

## Spring Brakes — Manual Release

In order to tow a vehicle, if there is insufficient air to release the parking brake, the spring brakes can be manually released.



**WARNING! Never drive your vehicle with the parking brake applied. Always release the parking brakes prior to moving the vehicle. Failure to disengage the parking brakes prior to moving your vehicle could result in excessive heat build-up in the brake system, resulting in a fire.**



**NOTE:** Today's diesel electronic engines have significant torque and startability power at low RPM. Combinations of engine speed and available torque may over-power the vehicle's parking brakes.



**NOTE:** Suitable wheel chocks are at a minimum an 18-inch (46 cm) long 4x4.

## Emergency repairs



**WARNING! Do not drive vehicle with malfunctioning brakes. If one of the brake circuits should become inoperative, braking distances will increase substantially and handling characteristics while braking will be affected. You could lose control of your vehicle, be severely injured, or cause an accident. Have it towed to the nearest dealer or qualified workshop for repair.**

You may sometimes have to release your vehicle's spring brakes by hand. This could happen if the system air pressure does not reach operating pressure because your engine or compressor is not working properly. You will have to release the spring brakes at the spring brake chambers.



**WARNING! Do not disassemble a spring brake chamber. These chambers contain a powerful spring that is compressed. Sudden release of this spring can cause you to be severely injured.**

- **Do not operate a vehicle when the spring brakes have been manually released. Driving a vehicle after its spring brakes are manually released is extremely dangerous. You will probably have no brakes at all. You could have a serious or fatal accident.**
- **Releasing the spring brakes on an unsecured vehicle could lead to an accident. The vehicle could roll, causing severe injury. Always secure the vehicle with wheel chocks, chains, or other**

**safe means to prevent rolling before manually releasing the spring brakes.**

To move a vehicle immobilized by the spring brakes due to loss of air pressure in the brake system, perform the following procedure:

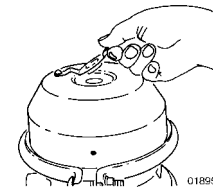

1. Block the wheels with chocks.
2. Remove the cap from the spring chamber.

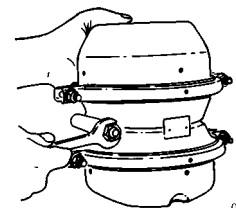

3. Remove the release stud assembly from the side pocket, and remove the release nut and washer from the release stud.

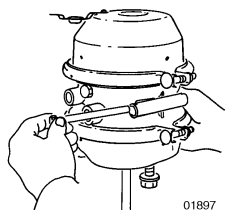

4. Slide out the release stud.

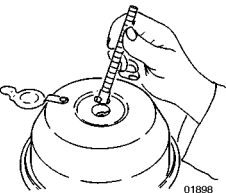

5. Insert the release stud through the opening in the spring chamber where the cap was removed.

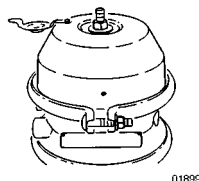

6. Assemble the release stud washer and nut on the release stud.

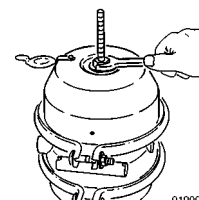

7. With a wrench, turn the release stud assembly nut until the compression spring is 90–95 percent caged.

While doing this, check to make sure the push rod (adapter push rod or service push rod) is retracting. Do not over-torque the release stud assembly. (S–Cam type maximum: 50 ft-lb.) The spring brake is now mechanically released.

## Jacking The Vehicle



**WARNING!** If you are not fully qualified and not equipped with the proper tools and equipment, do not attempt to raise the vehicle or remove or install a damaged tire and wheel assembly. Obtain expert help. A person can be seriously injured and/or damage can result from using the wrong service methods. Truck tires and wheels should be serviced only by trained personnel using proper equipment.

Before attempting to jack the vehicle, ensure the following:

- The complete vehicle is on stable level ground.
- The parking brake is applied and chocks have been positioned under the road wheels.

## Emergency repairs

- It is recommended that suitable supports are positioned beneath the appropriate axle when jacking the vehicle.

Locate the hydraulic jack under the road spring of the appropriate axle, as close as possible to the road wheel.

### Wheels



**WARNING!** *The road wheels and wheel nuts used on this vehicle are hub piloted; do not use any other type of road wheel or wheel nut*

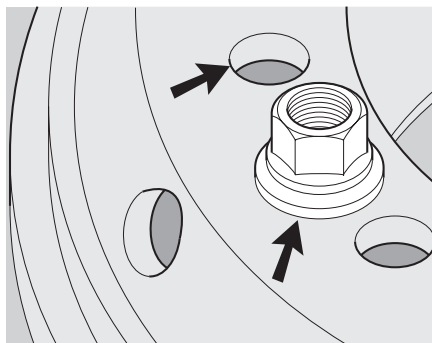

Hub-piloted wheels have the following characteristics:

- Wheels with cylindrical bolt holes.
- Wheel nuts with a loose (captive) flat thrust washer.

### Changing wheels

1. Chock the road wheels and position the jack under the appropriate axle, as close as possible to the wheel that is being changed.
2. Clean the wheel nuts or, if applicable, remove the protective cover from each wheel nut.
3. Loosen, but do **not** remove the wheel nuts.
4. Jack the axle until the road wheel(s) are clear of the ground. Remove the road wheel nuts and carefully detach the road wheel.
5. Before installing the road wheel, carefully clean the mating edge of the wheel hub and the inner edge of the spare wheel. Remove any burrs and traces of paint.

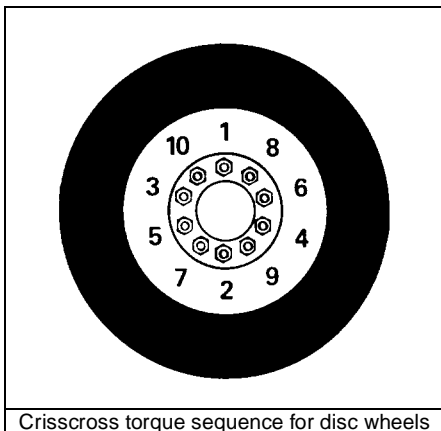

Crisscross torque sequence for disc wheels

6. Install the wheel and gradually tighten the wheel nuts in a criss-cross sequence to 450 to 500 lb. ft. (610 to 680 Nm).



**WARNING!** Grooves in the wheel disc or other damage to the disc can lead to a serious accident. The disc will be weakened and can eventually come off, maybe causing you to lose control of your vehicle. Be sure to use the right components and the right tools.

- **The end of the wheel wrench must be smooth. Burrs on the end of the wrench can tear grooves in the disc, especially on aluminum wheels. These grooves may lead to cracks in the disc, and can cause it to fail.**

When installing the rear wheels, ensure that the tire inflation valves are opposed 180° to each other to facilitate tire inflation and aid tire balance.



**WARNING!** Tighten wheel nuts properly. If they are not tightened properly, wheel nuts could eventually cause the wheel to become loose, to fail, and/or to come off while the vehicle is moving, possibly causing loss of control and/or personal injury or damage to the vehicle.

After the vehicle travels about 50 to 100 miles (80 to 160 km), wheel mountings “seat in” and will lose some initial torque. Check hub/wheel mountings after this initial period and retighten.

If any wheel bolt(s) need replacing, all the bolts of the same wheel **MUST** be replaced.

After changing a wheel, the difference in tire diameter between the various wheels on the vehicle **may** then be too



## Emergency repairs

large (caused, for example, by a difference in tread depths and/or tire pressures).

The ABS is not designed to deal with excessive differences of this nature, as a result the system will disengage and the ABS warning light will illuminate.

Dependent upon the type of tires fitted to the front and rear axles, this problem may occur with a worn tire which is under-inflated by approx 29 psi. Consequently, if the ABS warning light illuminates after a wheel/tire change, always check the tire pressure before checking anything else.

**This means that in extreme conditions the ABS will no longer operate!**

This is also why the maximum permitted difference in tire diameter for **new tires** is 7.5% (this may occur when different tire sizes are installed on the front and rear axles).

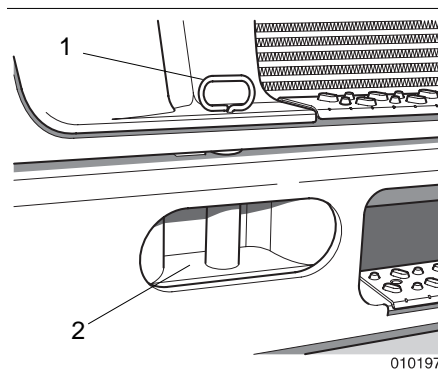

### Towing Pin

The front bumper incorporates a towing pin (1) that is fitted to the aperture of the bumper. The towing pin is secured

in position within the bumper through turning and allowing locking pin to move into retaining slot. The towing pin is suitable for all normal towing operations.

Ensure that the towing pin is secured in position. To check, attempt to lift pin vertically. It should **not** lift out.

When installed correctly, the towing pin should protrude through the bottom aperture plate (2), and allow a vertical movement of no more than ½ inch when lifted.

### Towing

If the vehicle requires towing, it is recommended that a suitable suspended towing procedure is employed.



**WARNING!** Do not attempt to tow the vehicle when it is fully laden. If the engine will not run, there will be no power assist to the steering and no air supply for the brakes.

**Being towed by another vehicle:**

- Ensure that the steering lock of the towed vehicle is **disengaged** (unless the vehicle is being towed with its front wheels hoisted clear of the road).
- To prevent possible damage to the transmission, the driveshaft must **always** be disconnected at the differential.
- If there is insufficient pressure in air reservoirs, release the parking brake as stated earlier in this section).

If the differential is damaged:

- Hoist the vehicle at the rear end and **engage** the steering lock.

**Replacing Bulbs**

**Headlights**

1. Remove four Torx head screws from the side marker light assemblies. There are two on each side of the headlight grille.
2. From behind the side marker lights, cut tie straps.
3. Pull assembly out and carefully remove the two inline connections on each side by carefully pulling them apart.
4. Remove four bolts from the front of the headlight grille, two on each side.
5. Remove two nuts from the back of the headlight grille.

6. Remove two center screws from the step plate in the center of the headlight grille.
7. Remove the headlight grille.
8. Remove four screws holding the headlight bezel in place and remove the headlight.
9. Replace the headlight and bezel.
10. Reverse the disassembly procedure and assemble all removed parts. Be sure to replace tie straps.

**Front Marker Lights**

- Reach behind bumper and apply pressure to one side of light. This will cause the light assembly to pop out. Disconnect and replace.



**NOTE:** Marker light is a sealed assembly and must be replaced as a unit, the bulb itself cannot be replaced.

## Emergency repairs

### Side Marker Lights



*NOTE: Marker light is a sealed assembly and must be replaced as a unit; the bulb alone cannot be replaced.*

1. Remove two torx head screws (1).

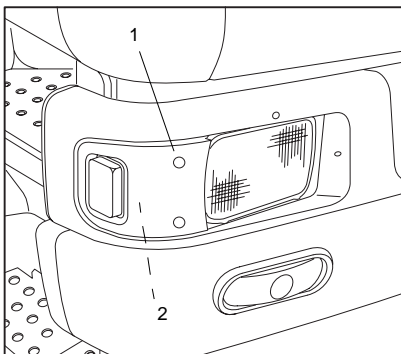

2. From behind side marker light assembly, clip tie wraps.
3. Pull assembly out and carefully remove the two inline connections (2) by pulling them apart.

4. Remove the sheet metal nut and carefully pry marker light off adhesive-backed foam.
5. If necessary, replace adhesive-backed foam pad.
6. Replace marker light.
7. Replace tie wraps.

### Side Lights

1. Find the tab on the yellow lens. Using a narrow blunt tool, such as a flat screwdriver, pry off the lens using a gentle twisting motion.
2. Change bulb.
3. Replace lens.

### Rear Lights

1. Locate the two tabs at the bottom of the housing. Pop open (down).
2. Lift outer cover and remove sealed lamp and install new one.

3. Lower cover and snap tabs back in place.

### Turn signal, front

1. Remove the two screws and then detach the turn signal light assembly.
2. Release the protective rubber cover from the bulb holder.
3. Rotate the bulb holder counter-clockwise and detach from the turn signal lamp assembly.
4. Lightly depress and then remove the bulb from the bulb holder.

## Emergency repairs

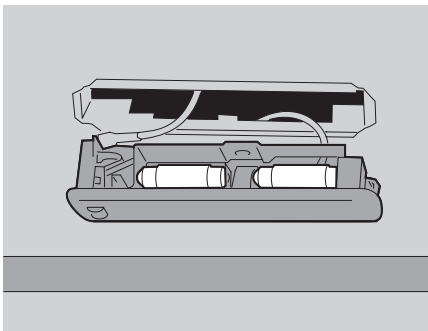

080505

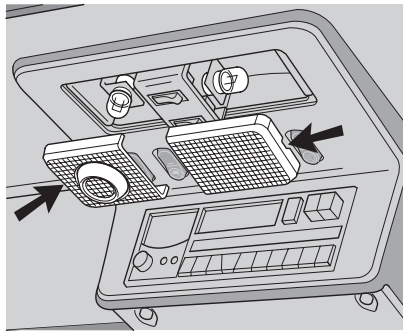

081156

### Courtesy light

1. Carefully pry the courtesy light assembly from the cab roof lining.
2. Detach the bulb(s) from the unit.



*NOTE: When replacing the courtesy light assembly, ensure that it is correctly located and secure.*

### Interior light unit

Each lens cover in the interior light unit is provided with an access slot to enable the internal lens catch to be released.

1. Insert a screwdriver into the required lens access slot and lightly depress the internal retaining catch; carefully pull the lens downwards from the interior light unit.

2. Remove the bulb from the unit.



*NOTE: When replacing the lens cover, ensure that it is correctly located and secure.*

## Emergency repairs

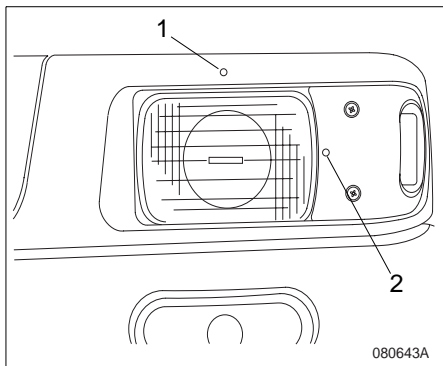

### Adjusting The Headlights

Before attempting to adjust the headlight beam alignment ensure that:

- All tires are inflated to their correct pressures.
- The vehicle is in an unladen condition.
- The vehicle is positioned with all wheels on level surface.

1. The two screws for adjusting the alignment of the headlights are accessible through the holes provided at the front of each headlight surround.
2. Adjusting screw (1) is for vertical alignment of the light beam. Adjusting screw (2) is for horizontal alignment of the light beam.



**NOTE:** Passenger side access hole for adjustment is to the right of the headlight.

### Fuses



**WARNING!** To avoid overloading the electrical circuits and the subsequent possibility of fire, do NOT fit a fuse that exceeds the recommended rating.



**WARNING!** Repeated failure of the same fuse indicates a circuit fault which MUST be investigated and rectified.

All standard circuit fuses are located in two fuse boxes on either side of the instrument panel.

Each blade type fuse is color coded to identify its amperage rating as follows:

Tan (5 amp)

Brown (7.5 amp)

Red (10 amp)

Blue (15 amp)

### Radio (optional)

The optional radio is installed in the cab roof center panel. To learn how to operate it, see the radio's "Operator's Manual" in the glove compartment.



*NOTE: All vehicles are fitted with a roof mounted antenna and a fully shielded extension lead.*



*NOTE: The radio power supply is controlled by the ignition switch.*

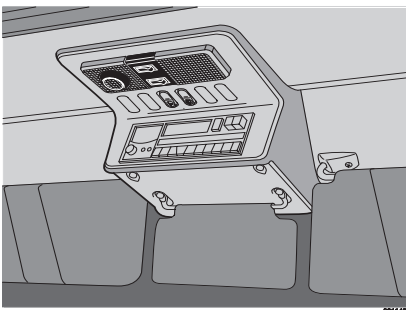

## Electrical Connections

To ensure safe electrical connections and also to prevent irreparable damage to any audio equipment being fitted, it is essential that the following recommendations are observed:

1. Before attempting to fit any audio equipment it is essential that the electrical connectors on the rear of the audio equipment are correctly identified in accordance with the audio manufacturers instructions.
2. The color coded connectors contained in the radio aperture provide the following functions:
  - Brown (A):speakers
  - Grey (B): Power supply

Connect the DIN connectors to the corresponding connectors on the rear of the audio equipment.

## Speakers

All cabs are equipped with two speaker enclosures, complete with all necessary wiring, at either side of the cab. Before attempting to fit any speakers, ensure that the following information is observed:

- Ensure that the impedance and the power handling capacity of each speaker is suitable for the audio component application; refer to the manufacturers technical literature.
- To maintain maximum sound quality, it is important that the speaker cables are correctly connected to the corresponding positive (+) and negative (-) speaker terminals; incorrect connection will result in poor sound quality.

## Emergency repairs

### Noise and Emission Control

#### Noise Emission Warranty

PACCAR Inc warrants to the first person who purchases this vehicle (for purposes other than resale) and to each subsequent purchaser: that this vehicle, as manufactured by PACCAR Inc, was designed, built and equipped to conform, at the time it left PACCAR Inc's control, with all applicable U.S. EPA Noise Control Regulations.

This warranty covers this vehicle as designed, built, and equipped by PACCAR Inc, and is not limited to any particular part, component or system of the vehicle manufactured by PACCAR Inc. Defects in design, assembly or in any part, component or system of the vehi-

cle as manufactured by PACCAR Inc, which at the time it left PACCAR Inc's control caused noise emissions to exceed Federal standards, are covered by this warranty for the life of the vehicle.

#### Tampering with Noise Control System

##### Federal law prohibits the following acts or the causing thereof:

1. The removal or rendering inoperative by any person other than for purposes of maintenance, repair, or replacement, of any device or element of design incorporated into any new vehicle for the purpose of noise control prior to its sale or delivery to the ultimate purchaser or while it is in use, or

## Noise and Emission Control

2. The use of the vehicle after such device or element of design has been removed or rendered inoperative by any person.

Among those acts presumed to constitute tampering are the acts listed below:

#### Air Intake System

- Removing or rendering inoperative the air cleaner/silencers or intake piping.

#### Engine Cooling System

- Removing or rendering inoperative the fan clutch.
- Removing the fan shroud.

#### Engine

- Removing or rendering engine speed governor inoperative so as to allow engine speed to exceed manufacturer's specifications.
- Modifying ECU parameters.

## Noise and Emission Control

## Emergency repairs

### Exhaust System

- Removing or rendering inoperative exhaust system components.

### Fuel System

- Removing or rendering engine speed governor inoperative, allowing engine speed to exceed manufacturer's specifications.
- Removing of air signal attenuator on engines equipped with this device.

### Inner Fender Shields

- Removing shield.
- Cutting away parts of shields or damaged or loose portions of shields.

### Noise Insulating Blankets

- Removing noise insulators from engine block or from around the oil pan.
- Cutting holes in, or cutting away part of noise insulators.

- Removing hood-mounted noise insulation.

## Inspection and Maintenance Instructions

If, during periodic inspection and maintenance of other systems and components, it is found that parts of the noise control system require attention, we recommend that those parts be inspected at more frequent intervals to assure adequate maintenance and performance.

### Air Intake System

- Do all checks and maintenance procedures listed in this manual under Engine Air Intake System and Air Cleaner. See "[Maintenance and Lubrication Intervals](#)" on [page 72](#).

- Check the air intake tubing, elbow connections, clamps, brackets, and fasteners for deterioration, cracks, and condition.
- If you find an air leak anywhere between the air cleaner and the engine, repair that leak immediately.



**CAUTION: Air leaks cause excessive noise and may result in serious damage to the engine. If you do not repair them the engine damage will not be covered by your warranty. Repair all air leaks as soon as you find them.**

### Exhaust System

- Check for exhaust leaks, which could indicate a leaking manifold gasket; replace gasket if necessary.



## Emergency repairs

- Check exhaust manifold cap screws for tightness, including those at the flanges. Refer to the engine manufacturer's service manual for proper tightening sequence and torque values.

### Joists and Clamps

- Check for leaks, and tighten as necessary. Check for deterioration or dents in pipes and clamps which could allow exhaust to escape.

### Piping

- Check exhaust piping for rust, corrosion, or damage. Replace deteriorated piping before holes appear. If piping is perforated at any point, temporary patching or lagging is acceptable until you can have permanent repairs made. On turbo-

charged engines, check joints at flanges and mounting brackets for tightness.

### Mufflers

- Check muffler, clamps, and mounting brackets. Tighten if necessary. Inspect muffler for signs of rust or corrosion.
- Check internal baffling. You can do this by listening for rattling sounds while tapping the muffler with a rubber mallet or revving the engine up and down through its normal operating range.

### Exhaust Tail Pipe

- Check the mounting. Tighten as necessary. Do not modify the end of the pipe in any way.

## Noise and Emission Control

### Engine Fan and Shroud



***WARNING! Do not work on the fan with the engine running. The engine fan can engage at any time without warning. Anyone near the fan when it turns on could be seriously injured. Before turning on the ignition, be sure that no one is near the fan.***

- Check all fasteners for tightness. Check for stress cracks in the fan and shroud. Make sure the shroud is adjusted so that it does not touch the fan blades.
- Check fan blade mounting bolts. Inspect fan blades to be sure they are not cracked or bent. If problems exist, refer to the Cooling System section in the maintenance manual for detailed maintenance instructions.

### **Transmission and Driveline**

- Substituting a different main transmission or drive line components, other than design-specified units, may result in increased vehicle noise emission and/or undesirable vibrations.

## CONSUMER INFORMATION AND VEHICLE IDENTIFICATION

### Reporting Safety Defects

If you believe that your vehicle has a defect which could cause a crash or could cause injury or death, you should immediately inform the National Highway Traffic Safety Administration (NHTSA) in addition to notifying PAC-CAR Inc.

If NHTSA receives similar complaints, it may open an investigation, and if it finds that a safety defect exists in a group of vehicles, it may order a recall and remedy campaign. However, NHTSA cannot get involved in individual problems between you, your Dealer, and PAC-CAR Inc.

To contact NHTSA, you may either call the Auto Safety Hotline toll-free at 1-800-424-9393 (366-0123 in Washington, D.C.) or write to: Administrator, NHTSA, 400 Seventh Street, S.W., Washington, D.C. 20590. You can also get other information about auto safety from the Hotline.

### Vehicle Identification

All vehicles are identified by a 17-digit Vehicle Identification Number (VIN). This unique numeral and letter combination identifies the manufacturer, the model year it was built, and other vehicle attributes. The VIN is in compliance with US Federal Motor Vehicle Safety Standard 49 CFR 567 Certification or

Canadian Motor Safety Std No. 115. As an example, the model year and assembly plant are designated by a letter in the tenth and eleventh character positions (see 4 and 5 below).

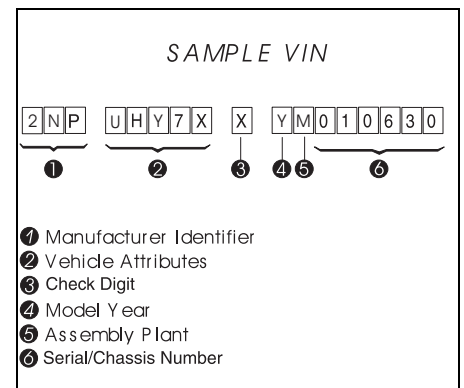

Vehicle Identification Number (VIN)

- The Chassis/Serial Number refers to the last seven characters of the VIN, including the assembly plant designator (eleventh character position) and a six-digit serial number. This number will allow your Dealer to identify your vehicle. You will be asked for this number when you bring your vehicle in for service.

**Table 5** Model Year Letter Designations

CODE	YEAR
Y	2000
1	2001
2	2002
3	2003
4	2004

**VIN Location**

The VIN is marked in multiple locations: on the Complete Vehicle Certification Label, the Incomplete Vehicle Certification Label, and the Final-Stage Manufacturer Label.

**Chassis Number Locations**

The chassis/serial number is shown in three places:

- Right frame rail, top flange, about three feet from the front end.
- Components and Weights Label on driver's door frame.
- Tire and Rim Info Label on driver's door frame.

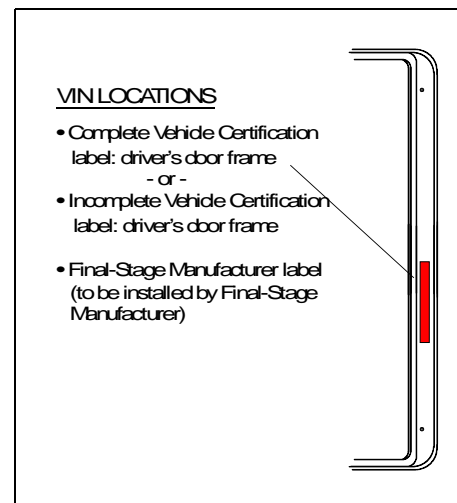

### Complete Vehicle Certification Label

The Complete Vehicle Certification label certifies that the vehicle complies with all applicable Federal Motor Vehicle Safety Standards. It is located on the driver's side door frame and contains the following information:

- Date of manufacture.
- GVWR — Gross Vehicle Weight Rating.
- GAWR FRONT and REAR — Gross Axle Weight Ratings for Front and Rear Axle.
- TIRE/RIM SIZES AND INFLATION PRESSURES — Tire/Rim Sizes and Cold Pressure Minimums.
- VIN — Vehicle Identification Number.

### Incomplete Vehicle Certification Label

The Incomplete Vehicle Certification Label (for trucks) is located on the driver's door frame. It contains the following information:

- DATE OF MANUFACTURE.
- VIN — Vehicle Identification Number.
- LISTING OF APPLICABLE FEDERAL MOTOR VEHICLE SAFETY STANDARDS.

### Tire and Rim Information Label

The Tire and Rim Information Label (for trucks) is located on the driver's door frame. It contains the following information:

- GVWR — Gross Vehicle Weight Rating.
- GAWR FRONT and REAR — Gross Axle Weight Ratings for Front and Rear Axle.
- TIRE/RIM SIZES AND INFLATION PRESSURES — Tire/Rim Sizes and Cold Pressure Minimums.
- Chassis No.



**WARNING! Do not exceed the specified load rating. Overloading can result in loss of vehicle control and personal injury, either by causing component failures or by affecting vehicle handling. Exceeding load ratings can also shorten the service life of the vehicle.**



*NOTE: GVW is the TOTAL SCALE WEIGHT the vehicle is designed to carry. This includes the weight of the empty vehicle, loading platform, occupants, fuel, and any load.*

The tire size and rim size (and the cold inflation pressure to match that combination) listed under "Suitable Tire-Rim Choice" on the Certification Label are only representative examples for the specified axle ratings. These components may not be the ones actually installed on the axle, because there are many other appropriate combinations.

The "PSI Cold" inflation pressure on the Certification Label is for the tire-rim combination in the example, and may not be the same as the recommended inflation pressure for the actual tires on that axle.

Check the manufacturer's product information for the tires and rims actually on each axle to obtain recommended tire inflation pressure for specific applications.

### **Noise Emission Label**

The Noise Emission Label is on the driver's door frame. It contains information regarding U.S. noise emission regulations and date of manufacture.

### **Paint Data Label**

The Paint Data Label contains the paint colors used by the factory to paint your vehicle. It lists frame, wheels, cab interior and exterior colors. This label is located on the back of the glove box compartment visible from the passenger seat.

### **Federal Safety Standard Certification Label**

The NHTSA regulations require a label certifying compliance with Federal Safety Standard, for United States and U.S. Territories, be affixed to each motor vehicle and prescribe where such label may be located. This certification label, which indicates the date of manufacture and other pertinent information, is located on the driver's side door frame.

## Component Identification

Each of the major components on your vehicle has an identification label or tag. For easy reference, record component numbers such as, model, serial, and assembly number. See the [“Vehicle Component Register”](#) (last page of this manual).

**Engine:** For further information, please refer to the *Engine Operation and Maintenance Manual*.

**Clutch:** Enclosed in clutch housing. Location depends on manufacturer.

**Transmission:** The identification number is stamped on a tag affixed to the right rear side of the transmission case.





## **GENERAL ALPHABETICAL INDEX**

### **A**

A/C On/Off Switch 32  
ABS Warning Light 30  
Adjustable steering column 45  
Air dryer 54  
Air filter restriction indicator 53  
Air intake 105  
Air loss emergency procedure 29  
Air Pressure Gauge "Primary" 38  
Air Pressure Gauge "Secondary" 38  
Alternator precautions 3  
Anti-lock brakes 65  
Anti-Lock Braking System ABS 65  
Ashtray 24  
Automatic transmission 62  
    operating 62  
Axle weight rating 111

### **B**

Ball bearing grease 84  
Battery 6  
    electrolyte 8

Battery Charge Warning Light 29  
Battery, charging 7  
Belts, seat 19  
Brake  
    system - towing and spring brakes 94  
    system malfunction 95  
Brakes  
    ABS 65  
    adjustment 94  
    parking brake/emergency brake 66  
    service brake 66  
Bulbs, also see replacing bulbs

### **C**

Cab  
    bunk 21  
    center roof console 42  
    cleaning 12  
    doors 14  
    entry and exit 13  
    heater precautions 32

Cab (continued)  
    maintenance 12  
    mirrors 16  
    roof vent 23  
Cab-lock Warning Light 28  
Chassis  
    grease 84  
    number 110  
Check Engine Light 30  
Check Transmission Warning Light 31  
Cigarette Lighter 24  
Clutch 59  
    clutch adjustment 61  
    fluid level 55  
    operating the clutch 59  
    riding the clutch 61  
Coasting 62  
Controls Around The Steering Column 44  
Coolant Temperature Gauge 31  
Coolant Temperature Warning Light 30  
Cooling 37

## General Alphabetical Index

Cooling system  
  coolant level 51  
  temperature gauge 31  
  warning light 30  
Courtesy Lights 23  
Cruise control  
  operation 64  
Cruise Control On/Off Switch 40  
Cruise Control Set/Resume Switch 40  
Cruise Control Warning Light 28

### D

Daily maintenance 50  
Daily operations 48  
Defogging 37  
Defogging/defrosting system 32  
Differential Lock Warning Light 29  
DON'T SHIFT light 63  
Door windows 14  
Doors 14  
Downshift 61  
Driver's  
  checklist 47  
  daily and weekly checks 47, 48, 50  
Driving 57

### E

Electrical system  
  battery charging 7, 9, 10  
  jumper cables 8  
Electrolyte 8  
Emergency brake, see parking brake  
Emergency repairs 93  
Engine  
  belt tension 48  
  cooling system 51  
  daily checks 47  
  identification 113  
  oil level 50  
  starting procedure 58  
Exhaust  
  brake 68

### F

Fan blade 107  
Federal motor regulations 50  
Federal safety label 112  
Fire extinguisher 4  
First aid kit 4  
Front access panel 50  
Fuel  
  filter 48

Fuel Gauge 31  
Fuel system  
  fuel filter 94  
Fuses 103

### G

GAWR - gross axle weight rating 111  
Glove box 21  
GVWR - gross vehicle weight rating 111

### H

Hazard flasher 29  
Hazard Switch Warning Light 28  
Hazard Warning Light Switch 40  
Headlight height adjustment 103  
Heater and air conditioner 32  
  controls 37  
  defogging 37  
Heater And Air Conditioner Controls 32  
Heating 36  
Heating and ventilation  
  air vents, fixed and adjustable 34  
  controls 32

High Beam Warning Light 28  
Horn 45

**I**

Incomplete vehicle certification label 111  
Inflating tires 52  
Instrument panel 26  
Instrument Panel Lighting Switch 43  
Instruments and controls 25  
Interior Light 43  
Interior Light Unit 24  
Introduction i

**J**

Jumper cables 8  
use of 8

**L**

Lighting switch 39  
Low Air Pressure Warning Light 29  
Lubrication  
chart 85  
specifications 84

types and brands 83

**M**

Maintenance  
activities 3  
before the winter season 88  
cab maintenance 88  
in special operating conditions 88  
Manual transmission 59  
Mirror heating 43  
Mirror Heating Switch 43  
Mirrors 16  
Muffler 107  
Multi-function switch, left 45  
Multi-function switch, right 46

**N**

Noise and emission control 105  
air intake system 105  
engine 105  
exhaust system 106  
fan drive 105

**O**

Oil  
specifications 84  
Oil Pressure Warning Light 28  
OPERATING LEVER, PARKING BRAKE  
41  
Operating the transmission 59  
Optional equipment 62, 63, 67

**P**

Paint identification label 112  
Parking brake 41  
brake system, operation 62, 63, 94  
use 29, 60  
Parking Brake Warning Light 29  
Pencool 2792 6  
Penray Stabil-Aid 6  
Periodic maintenance 71  
PTO Warning Light 28

**R**

Radio 103  
Release bearing wear 61

## General Alphabetical Index

Replacing bulbs  
courtesy light 102  
direction indicators, front 101  
headlights 100  
interior light 102  
rear lights 101  
side lights 101

Retarders  
engine 67  
Roof Vent (option) 23

### S

Safety  
signals ii  
Safety precautions 1  
Safety symbol i  
Seat adjustment 17  
Seat belts 18  
Seats 17  
driver's seat (adjustable) 18  
passenger's seat (2-man) 18  
passenger's seat (single adjustable) 18

Serial number 110  
Shifting gears 60, 61, 62  
Shifting gears in a new vehicle 60  
Speedometer/Odometer 39  
Spring brakes - manual release 95  
Starting procedure 58  
Steering column, adjustable 45  
Stop Engine Light 30  
Stopping 69  
Storage Tray 21  
Sun Visors 22  
Switches  
hazard warning lights 28  
ignition switch 57  
instrument panel lighting 43  
mirror heating 43  
vehicle lighting 39

### T

Tachometer 28  
Tilting the Cab 14  
Tools, see vehicle tool kit  
Towing 94, 99  
Towing Pin 46  
Transmission  
automatic 62  
clutch 59  
identification 113  
manual 59  
operation 59  
Transmission Oil Temperature Warning  
Light 30  
Turn Signal Warning Light 28

### V

Vehicle  
weight rating 111  
Vehicle tool kit 93  
Vehicle, jacking 96

---

## General Alphabetical Index

### W

- Wait to Start Light 30
- Warning Lights
  - ABS 30
- Warning lights
  - battery charge 29
  - cab lock down 28
  - coolant temperature 30
  - hazard warning 28
  - headlight main beam 28
  - low air 29
  - oil pressure 28
  - parking brake 29
  - stop engine 30
  - wait to start 30
- Warranty 3, 105, 106
- Weekly maintenance 53
- Welding 3
- Wheels
  - changing wheels 97
- Wheels and tires
  - tightening sequence 98
- Windscreen wipers 17



General Alphabetical Index

---

Your servicing Dealer is

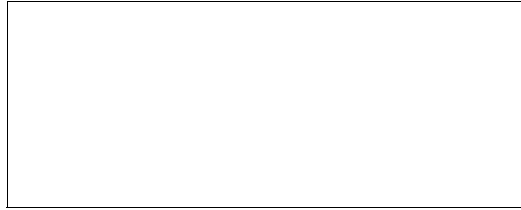

**Peterbilt Motors Company**  
P.O. Box 90208  
Denton, Texas 76202  
A DIVISION OF **PACCAR**

PB1340A 9/00

Printed in U.S.A.