

# **MP series**

## **SERVICE MANUAL**

**YAMAHA**  
®

P/N: 0BMP0-U00100

**INDUSTRIAL  
ENGINES**

---

This *Service Manual* has been developed for the exclusive use of service and repair professionals such as Yanmar authorized Distributors and Yanmar authorized Dealers. It is written with these professionals in mind and may not contain the necessary detail or safety statements that may be required for a non-professional to perform the service or repair properly and / or safely. Please contact an authorized Yanmar repair or service professional before working on your Yanmar product.

**Disclaimers:**

All information, illustrations and specifications in this manual are based on the latest information available at the time of publishing. The illustrations used in this manual are intended as representative reference views only. Moreover, because of our continuous product improvement policy, we may modify information, illustrations, and / or specifications to explain and / or exemplify a product, service, or maintenance improvement. We reserve the right to make any change at any time.

Yanmar and **YANMAR** are registered trademarks of Yanmar Co., Ltd. in Japan, the United States and / or other countries.

**All Rights Reserved:**

No part of this publication may be reproduced or used in any form by any means - graphic, electronic or mechanical, including photocopying, recording, taping, or information storage and retrieval systems - without the written permission of Yanmar Co., Ltd.

© 2007 Yanmar Co. Ltd.

0107

# TABLE OF CONTENTS

---

	<b>Page</b>
Table of Contents .....	iii
Introduction.....	1-1
Safety .....	2-1
General Service Information.....	3-1
Governor .....	4-1
Fuel Injection Pump.....	5-1
Adjustment .....	6-1
Fuel Injection Nozzle .....	7-1
Troubleshooting.....	8-1

**This Page Intentionally Left Blank**

## *Section 1*

# **INTRODUCTION**

---

This manual describes the features, service, adjustment and troubleshooting procedures of the Yanmar MP2 and MP4 fuel injection pump models used on TNV Direct Injection (DI) engines.

The fuel injection pump is an essential component of the diesel engine and is designed to respond to engine load.

To provide proper engine performance, the components of the fuel injection system are manufactured to very close tolerances. The fuel injection pump is assembled by Yanmar in a special clean air facility, to ensure all parts are completely clean during assembly. It is highly important that when servicing the fuel injection pump to keep the workplace clean. Any type of debris, dust or rust ingested into the pump, may damage the pump and cause faulty operation.

Yanmar products are continuously undergoing improvement. Contact your fuel injection equipment central distributor for service manual updates and current service bulletin information.

# INTRODUCTION

---

**This Page Intentionally Left Blank**

## Section 2

# SAFETY

---

	<b>Page</b>
Safety Statements .....	2-3
Safety Precautions .....	2-4

# SAFETY

---

**This Page Intentionally Left Blank**



## SAFETY STATEMENTS

Yanmar considers safety of great importance and recommends that anyone that comes into close contact with its products, such as those that install, operate, maintain or service Yanmar products, exercise common sense and comply with the safety information in this manual and on the safety labels. Keep the labels from becoming dirty or torn and replace them if they are lost or damaged. Also, if you need to replace a part that has a label attached to it, make sure you order the new part and label at the same time.



This safety alert symbol appears with most safety statements. It means attention, become alert, your safety is involved! Please read and abide by the message that follows the safety alert symbol.

### DANGER

**Danger (the word "DANGER" is in white letters with a red rectangle behind it) - indicates an imminently hazardous situation which, if not avoided, will result in death or serious injury. Danger is limited to the most extreme situations.**

0000001en

### WARNING

**Warning (the word "WARNING" is in black letters with an orange rectangle behind it) – indicates a potentially hazardous situation which, if not avoided, could result in death or serious injury.**

0000001en

### CAUTION

**Caution (the word "CAUTION" is in black letters with a yellow rectangle behind it) – indicates a potentially hazardous situation which, if not avoided, may result in minor or moderate injury.**

0000001en

### CAUTION

**Caution without the safety alert symbol indicates a potentially hazardous situation that can cause damage to the machine, personal property and / or the environment or cause the machine to operate improperly.**

0000001en

# SAFETY

## SAFETY PRECAUTIONS

**! DANGER**



**FIRE AND EXPLOSION HAZARD!**

- Diesel fuel is flammable and explosive under certain conditions.
- NEVER use diesel fuel as a cleaning agent.
- When transferring diesel fuel from one container to another, ALWAYS place one container on the ground to help prevent static electricity buildup, which could cause sparks and ignite fuel vapors.
- When servicing fuel pump components, ALWAYS use an approved container to catch any fuel that may leak.
- NEVER use a shop rag to catch the fuel. Vapors from the rag are flammable and explosive.
- ALWAYS wipe up any fuel spills immediately.
- ALWAYS wear eye protection. The fuel system is under pressure and fuel could spray out when you remove fuel system components.
- Failure to comply will result in death or serious injury.

000009enMP

**! DANGER**



**FIRE HAZARD!**

- ALWAYS keep fire extinguishers handy in case of fire. Clearly indicate the location of the fire extinguishers with a safety sign.
- ALWAYS ensure that the type of fire extinguishers are appropriate for material that might catch fire. Check with local authorities.
- ALWAYS have all fire extinguishers checked periodically for proper operation and / or readiness.
- ALWAYS post evacuation routes prominently. Periodically conduct fire drills.
- ALWAYS ensure that appropriate fire detection and extinguishing equipment are installed and checked periodically for proper operation. Check with local authorities.
- Failure to comply will result in death or serious injury.

000018en

**! WARNING**



**ALWAYS wear SAFETY GLASSES while servicing the engine to prevent possible eye injury.**

000013en

**⚠ WARNING****HIGH-PRESSURE HAZARD!**

- **ALWAYS** avoid skin contact with the high-pressure diesel fuel spray caused by a fuel system leak such as a broken fuel injection line. High-pressure fuel can penetrate your skin and result in serious injury. If you are exposed to high-pressure fuel spray, obtain prompt medical treatment.
- **NEVER** check for a fuel leak with your hands. **ALWAYS** use a piece of wood or cardboard.
- Failure to comply could result in death or serious injury.

000008enMP

**⚠ WARNING****FUME / BURN HAZARD!**

- **ALWAYS** read and follow safety related precautions found on containers of hazardous substances like parts cleaners, primers, sealants and sealant removers.
- Failure to comply could result in death or serious injury.

000014en

**⚠ WARNING****EXPOSURE HAZARD!**

- **ALWAYS** wear personal protective equipment such as gloves, work shoes, eye and hearing protection as required by the task at hand.
- **NEVER** wear jewelry, unbuttoned cuffs, ties or loose-fitting clothing when you are working near moving / rotating parts such as the cooling fan, flywheel or PTO shaft.
- **ALWAYS** tie back long hair when you are working near moving / rotating parts such as a cooling fan, flywheel, or PTO shaft.
- **NEVER** operate the engine while wearing a headset to listen to music or radio because it will be difficult to hear the alert signals.
- Failure to comply could result in death or serious injury.

000005en

**⚠ WARNING**

- **NEVER** inject fuel toward you. Since the fuel is injected at high pressure from the nozzle, it may penetrate the skin, resulting in injury.
- **NEVER** inject fuel toward a fire source. Atomized fuel is highly flammable and may cause a fire or burn skin.

000028en

**This Page Intentionally Left Blank**

### *Section 3*

# **GENERAL SERVICE INFORMATION**

---

	<b>Page</b>
Fuel Injection Pump.....	3-3
Fuel Injection Pump Nameplate .....	3-3
Specifications .....	3-4
Measuring Instruments.....	3-4
Pump Torque Specifications (MP2 / MP4 Models).....	3-6
Governor Torque Specifications (MP2 / MP4 Models) .....	3-8

## GENERAL SERVICE INFORMATION

---

**This Page Intentionally Left Blank**

## FUEL INJECTION PUMP

The MP fuel injection pump was developed for use on Yanmar Direct Injection (DI) diesel engines to comply with new exhaust gas emission regulations.

The MP fuel injection pump is a mono-plunger fuel pump that utilizes a distribution shaft to deliver equal amounts of fuel to each cylinder.

### Fuel Injection Pump Nameplate

The fuel injection pump nameplate is located on the outside of the aluminum pump body. The fuel injection pump eleven digit part number (**Figure 3-1, (1)**), identification number (**Figure 3-1, (2)**) and manufacture date code (**Figure 3-1, (3)**) are located on the name plate. The information on the fuel injection pump nameplate is required for calibration and service parts information.

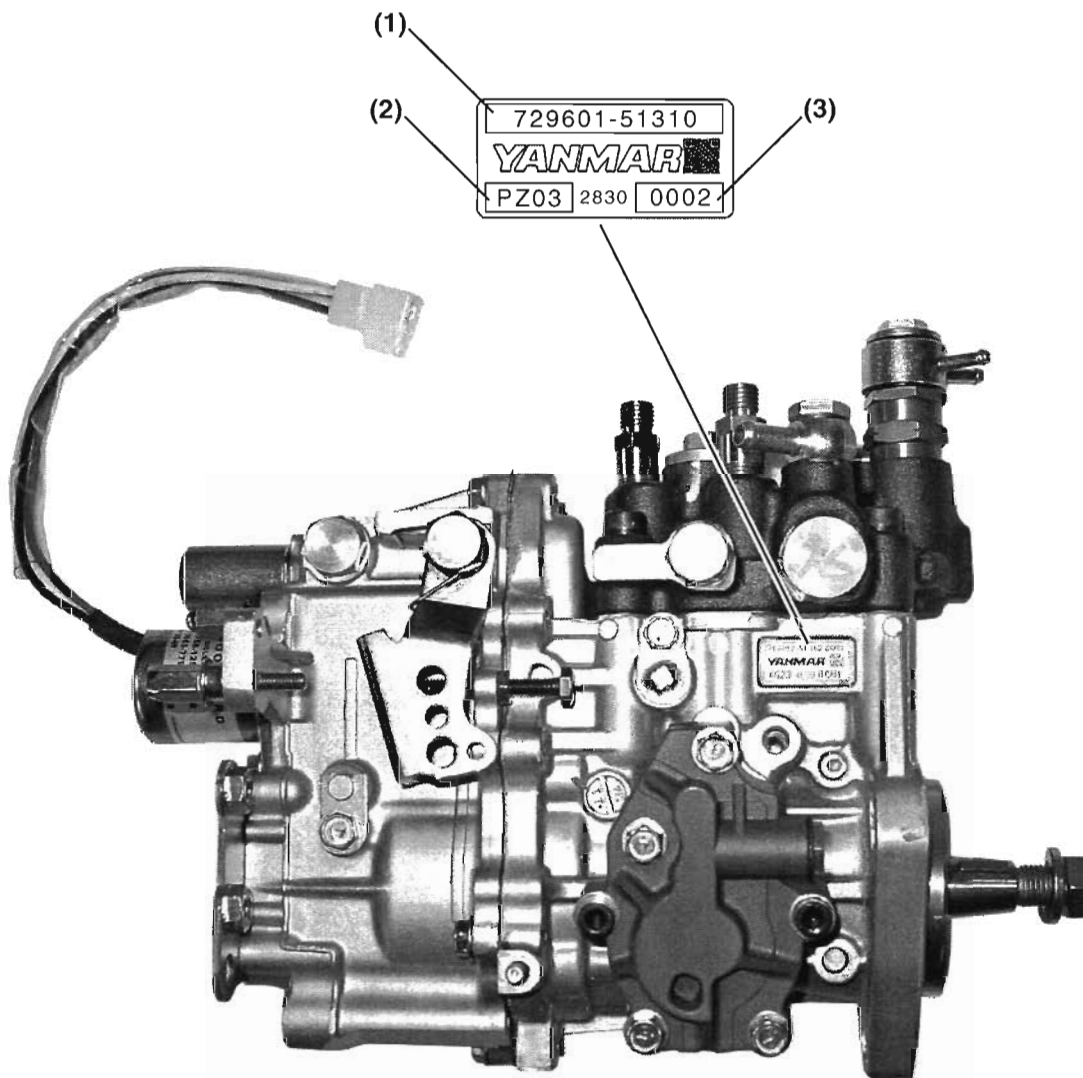

Figure 3-1

## GENERAL SERVICE INFORMATION

### SPECIFICATIONS

Model	3MP2	4MP2	4MP4
Engine	3TNV82A/84(T)/88	4TNV84(T)/88	4TNV94/98(T)106(T)
Dry Weight	18.5 lb (8.4 kg)	19.0 lb (8.6 kg)	25.4 lb (11.5 kg)
Plunger Diameter	0.35 in (9mm)		0.40 in (10mm)
Cam Lift (Maximum)	0.32 in (8.1mm)		0.40 in (10mm)
Governor Tension Lever Side Clearance	0.001 - 0.002 in. (0.3 - 0.6 mm)		
Control Lever Side Clearance	0.001 - 0.002 in. (0.3 - 0.6 mm)		
Governor	Mechanical All Speed Governor		
Fuel Injection Timing	Internal Hydraulic Control Timer		
Fuel Delivery	Trochoid Gear Charge Pump		
Lubrication	Engine Oil		

### MEASURING INSTRUMENTS

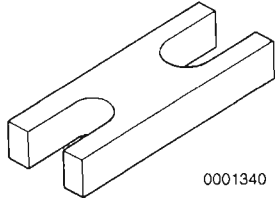
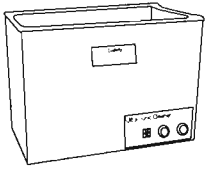
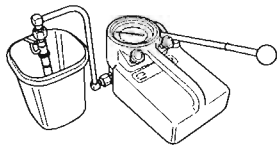
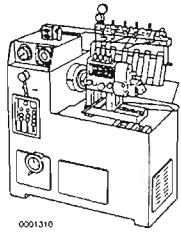
Name of tool		Image
Fuel Nozzle Mount Plate Yanmar Part No. 158090-51700	For holding and protecting fuel nozzle when servicing	 0001340
Ultra-Sonic Parts Cleaner (Locally Available)	For cleaning parts	 0004195
Fuel Injector Tester (Locally Available)	For observing injection spray pattern of fuel injection nozzle and measuring injection pressure	
Fuel Injection Pump Tester	For dynamically adjusting the fuel injection pump assembly and governor	 0001310



# GENERAL SERVICE INFORMATION

Name of tool	Image		
<p>Fuel Injection Pump Special Tool Kit P/N 458091</p> <p>Includes: Dial Indicator Set with Adapters and Plunger Spring Compressor</p>			
	(8)	(9)	(3)
	(1)	(4)	(6)
	(2)	(5)	(11-16)
	(7)	(10)	
			0003542a
No.	Item	Yanmar Part No.	Qty.
1	Carrying Case	15809000	1
2	Dial Indicator	15809001	1
3	30 mm Extension Rod	15809002	1
4	M14 Adapter	15809003	1
5	M16 Adapter	15809004	1
6	Adapter Nut	15809005	2
7	Lift Gauge, 28.55 mm	15809007	1
8	Lift Gauge, 25.5 mm	15809008	1
9	Lift Gauge, 25.9 mm	15809009	1
10	Lift Gauge, 26.3 mm	15809010	1
11 - 16	Base Spring Compressor	15809011	1
	Top, Spring Compressor	15809012	1
	Rod, Spring Compressor	15809013	2
	U-Nut, M8	26366-080002	2
	Bolt, M8x50	26450-080502	2
	Wing Nut M6	26636-060002	2

Note: Tools not having Yanmar part numbers must be acquired locally.

# GENERAL SERVICE INFORMATION

## PUMP TORQUE SPECIFICATIONS (MP2 / MP4 MODELS)

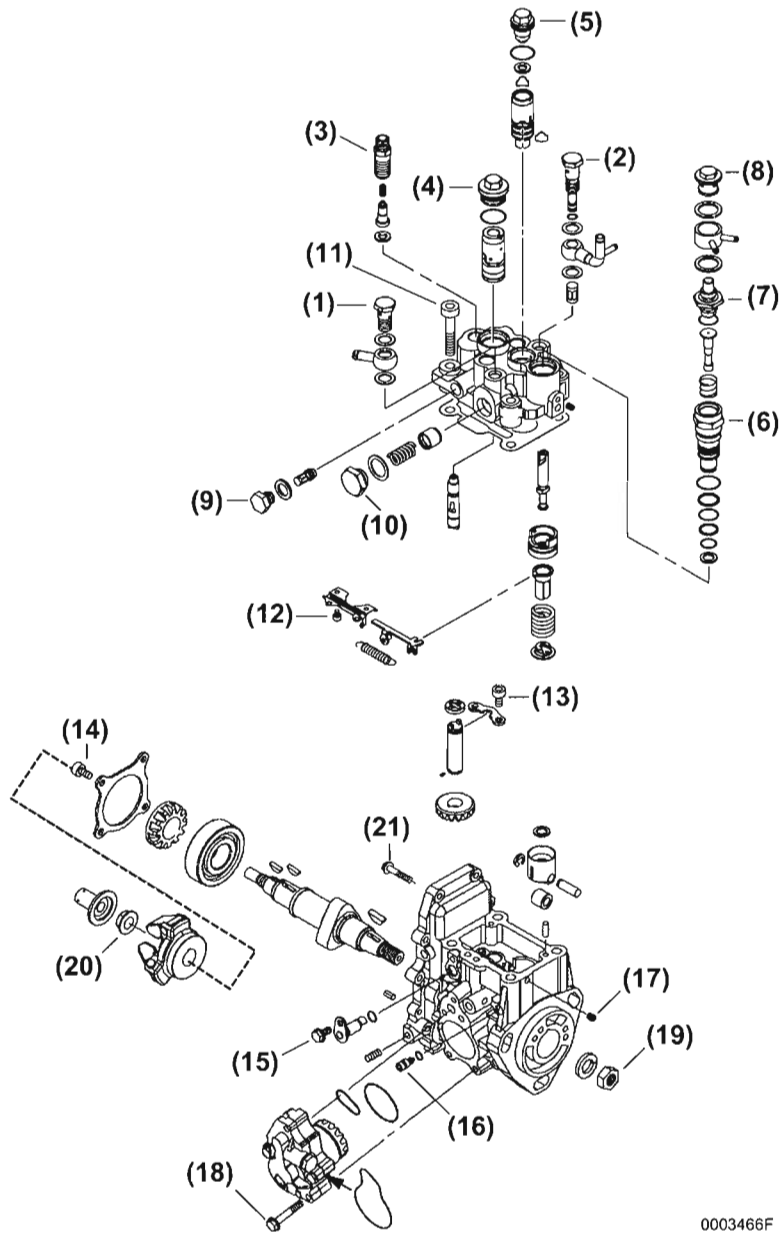

0003466F

Figure 3-2

**PUMP TORQUE SPECIFICATIONS (MP2 / MP4 MODELS)**

No.	Item	Tightening Torque		No.	Item	Tightening Torque	
		MP2 / MP4				MP2 / MP4	
1	Fuel Inlet Fitting	18 - 21 ft-lb (25 - 29 N·m)		12	Control Rack Guide Retaining Screw	2 - 3 ft-lb (3 - 4 N·m)	
		M12x1.25				M4x0.7 (hexagon socket head)	
2	Fuel Return Fitting	18 - 21 ft-lb (25 - 29 N·m)		13	Distribution Shaft Retainer Screw	6 - 7 ft-lb (8 - 10 N·m)	
		M12x1.25				M6x1 (hexagon socket head)	
3	Delivery Valve Holder	30 - 33 ft-lb (40 - 45 N·m)		14	Camshaft Bearing Retainer Screw	6 - 7 ft-lb (8 - 10 N·m)	
		M14x1.25				M6x1 (hexagon socket head)	
4	Distribution Shaft Plug	11 ft-lb (15 N·m)		15	Governor Link Retainer Shaft Screw	6 - 7 ft-lb (8 - 10 N·m)	
		M22x1				M6x1	
5	Plunger and Barrel Seal Plug	22 - 26 ft-lb (30 - 35 N·m)	33 - 37 ft-lb (45 - 50 N·m)	16	Roller Lifter Alignment Pin	3 - 4 ft-lb (4 - 5 N·m)	
		M14x1	M16x1			M6x1(hexagon socket head)	
		Early - M18X1, 37 - 41 ft-lb (50-55 N·m)					
6	Timer Holder	30 - 33 ft-lb (40 - 45 N·m)		17	Control Rack Plug	3 - 4 ft-lb (4 - 5 N·m)	
		M22x1				M6x1	
7	Thermo Element	22 - 26 ft-lb (30 - 35 N·m)		18	Charge Pump Bolts	6 - 7 ft-lb (8 - 10 N·m)	
		M16x1				M6x1	
8	Coolant Water Plug	16 - 18 ft-lb (22 - 25 N·m)		19	Camshaft Drive Nut	58 - 65 ft-lb (78 - 88 N·m)	83 - 91 ft-lb (113 - 123 N·m)
		M14x1				M14x1.5	M18x1.5
9	Charge Pump Fuel Outlet Strainer Plug	16 - 21 ft-lb (25 - 29 N·m)		20	Governor Weight Nut	59 - 62 ft-lb (79 - 84 N·m)	
		M12x1.25				M12x1.25	
10	Accumulator Plug	37 - 41 ft-lb (50 - 55 N·m)		21	Governor Housing Screw	6 - 7 ft-lb (8 - 10 N·m)	
		M20x1				M6x1	
11	Hydraulic Head Bolt	13 - 16 ft-lb (18 - 22 N·m)	21 - 24 ft-lb (28 - 32 N·m)				
		M8x1.25 (hexagon socket head)	M10x1.5 (hexagon socket head)				

## GENERAL SERVICE INFORMATION

### GOVERNOR TORQUE SPECIFICATIONS (MP2 / MP4 MODELS)

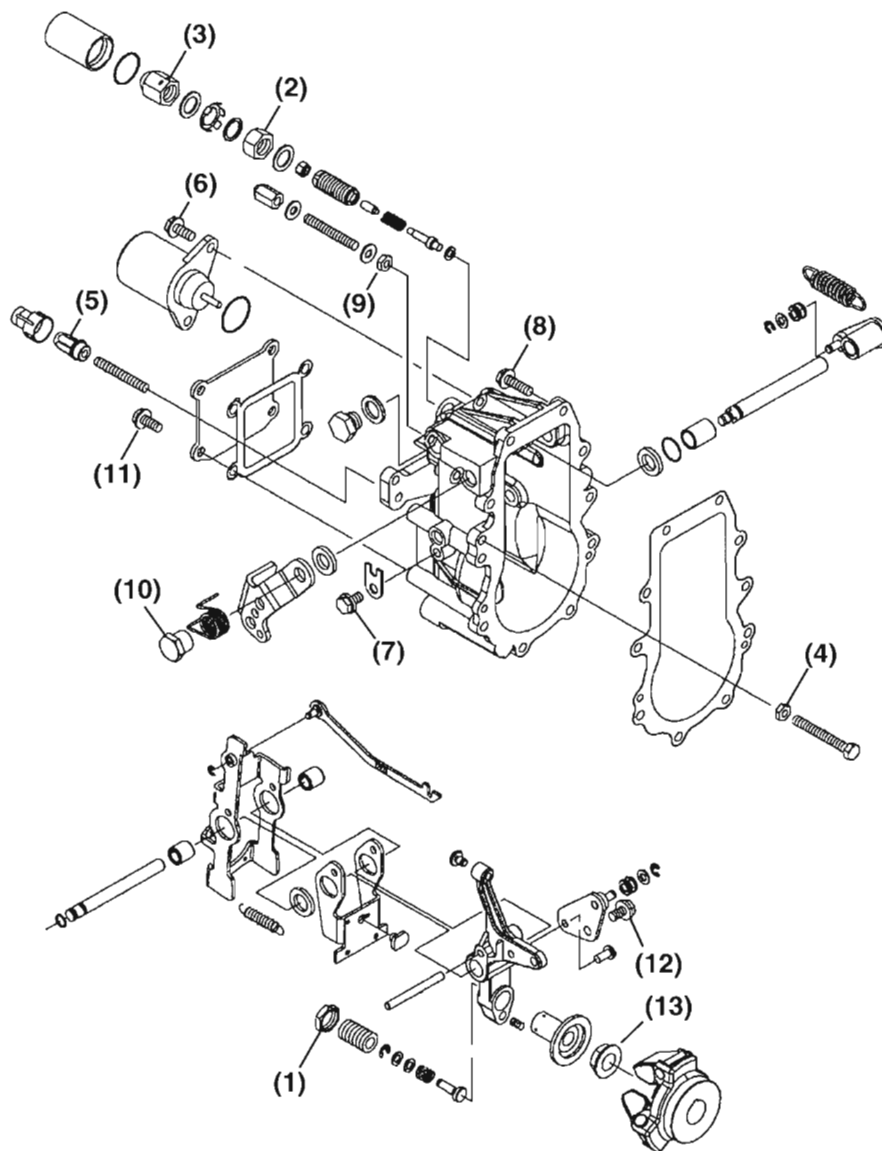

Figure 3-3

0003465C

**GOVERNOR TORQUE SPECIFICATIONS (MP2 / MP4 MODELS)**

No.	Item	Tightening Torque		No.	Item	Tightening Torque	
		MP2 / MP4				MP2 / MP4	
1	Angleich Lock Nut	18 - 21 ft-lb (25 - 29 N·m)		8	Governor Housing Bolt	6 - 7 ft-lb (8 - 10 N·m)	
		M14x1				M6x1	
2	Rated Fuel Limiter Lock Nut	15 - 16 ft-lb (20 - 22 N·m)		9	Starting Fuel Adjustment Lock Nut	6 - 7 ft-lb (8 - 10 N·m)	4 - 6 ft-lb (6 - 8 N·m)
		M12x1.25				M6x1	M5x0.8
3	Rated Fuel Limiter Cap Nut	15 - 16 ft-lb (20 - 22 N·m)		10	Control Lever Lock Nut	15 - 16 ft-lb (20 - 22 N·m)	
		M12x1.25			Lever Side Clearance	0.001 - 0.002 in. (0.3 - 0.6 mm)	
4	Low Idle Speed Lock Nut	6 - 7 ft-lb (8 - 10 N·m)		11	Cover Bolt	6 - 7 ft-lb (8 - 10 N·m)	
		M6x1				M6x1	
5	High Idle Speed Lock Nut	3 - 7 ft-lb (8 - 10 N·m)		12	Governor Tension Lever Retainer Bolts	4 - 6 ft-lb (6 - 8 N·m)	
		M6x1				M6x1	
6	Stop Solenoid Bolt	6 - 7 ft-lb (8 - 10 N·m)		13	Governor Weight Nut	59 - 62 ft-lb (79 - 84 N·m)	
		M6x1				M12x1.25	
7	Governor Lever Shaft Retainer Bolt	6 - 7 ft-lb (8 - 10 N·m)					
	Lever Side Clearance	0.001 - 0.002 in. (0.3 - 0.6 mm)					
		M6x1					

**This Page Intentionally Left Blank**

## Section 4

# GOVERNOR

---

	<b>Page</b>
Introduction.....	4-3
Governor Operation.....	4-4
Governor Components (MP2 / MP4 Models) .....	4-6
Governor Torque Specifications (MP2 / MP4 Models) .....	4-8
Governor Service .....	4-10
Removal .....	4-10
Disassembly .....	4-11
Assembly .....	4-14
Installation .....	4-17

**This Page Intentionally Left Blank**



## **INTRODUCTION**

This section of the *Service Manual* describes the operation of the governor, followed by the procedures necessary for disassembly, inspection and reassembly.

Diesel engines are used in a wide range of loads and speeds. The governor plays an important role in the operation of the engine by quickly adjusting the position of the control rack to control the amount of fuel injected, according to changes in engine speed.

The governor also prevents engine over speeding and provides for the engine stop function.

# GOVERNOR

## Governor Operation

The operation of the governor is a precise balancing act between the governor spring force and the governor weight assembly. The governor spring (**Figure 4-2, (12)**) is connected between the control lever shaft (**Figure 4-2, (9)**) and governor tension lever (**Figure 4-2, (26)**) which forces the governor link (**Figure 4-2, (28)**) to move the control rack.

As the fuel injection pump camshaft begins to rotate, centrifugal force causes the governor weights (**Figure 4-2, (33)**) to open pushing the governor sleeve (**Figure 4-2, (35)**) against the governor lever assembly (**Figure 4-2, (25)**), opposing the force of the governor spring.

At any set control lever position, an increase of load on the engine will try to slow the engine down, decreasing the centrifugal force from the governor weights which allows the governor spring tension to move the control rack (**Figure 4-1, (3)**) toward the full fuel volume position (**Figure 4-1, (2)**). If the load decreases, the engine will speed up, increasing the centrifugal force from the governor weights. This pushes the sleeve, moving the governor lever assembly toward the fuel stop position and decreasing the fuel injection volume (**Figure 4-1, (1)**). This balancing act occurs continuously, keeping the engine RPM at the desired speed setting.

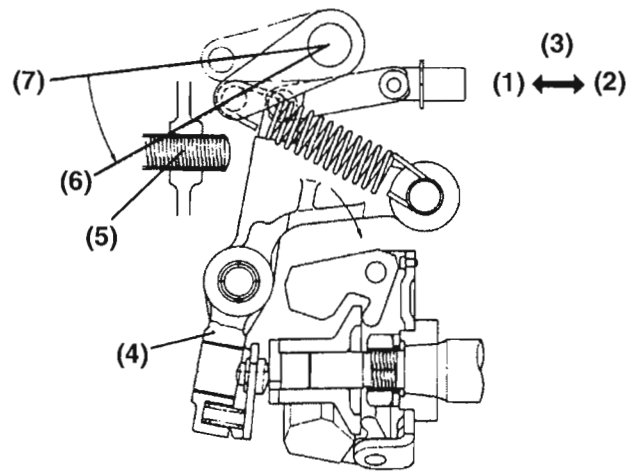

0001098a

1. Decrease of Fuel Volume
2. Increase of Fuel Volume
3. Control Rack Movement
4. Governor Tension Lever
5. Rated Fuel Limiter Adjustment Screw
6. Control Lever Idling Position
7. Control Lever Rated Speed Position

**Figure 4-1**

The electric stop solenoid (**Figure 4-2, (19)**) allows the governor to function while current is applied. The white lead will activate the pull coil and retract the plunger of the solenoid during cranking. The red lead activates the hold coil of the solenoid, keeping the plunger retracted during cranking and while the key switch is in the run position. When the key switch is turned off, the solenoid return spring and plunger moves the governor lever fully to the fuel stop position.

The following governor components are used to control the fuel delivery at specific points in the fuel delivery curve:

- Rated Fuel Limiter Assembly (**Figure 4-2, (17)**) = Rated load
- Angleich Spring Assembly (**Figure 4-2, (31)**) = Torque load
- High Idle Speed Adjustment Screw (**Figure 4-2, (15)**) = Maximum speed
- Low Idle Speed Adjustment Screw (**Figure 4-2, (18)**) = Minimum speed
- Starting Fuel Adjustment Screw (**Figure 4-2, (16)**) = Starting fuel delivery

A fuel limiter with a torque spring may be used and controls both rated and torque load delivery. EPA regulations require the use of tamper-proof covers for the rated fuel limiter and high idle screw.

# GOVERNOR

## GOVERNOR COMPONENTS (MP2 / MP4 MODELS)

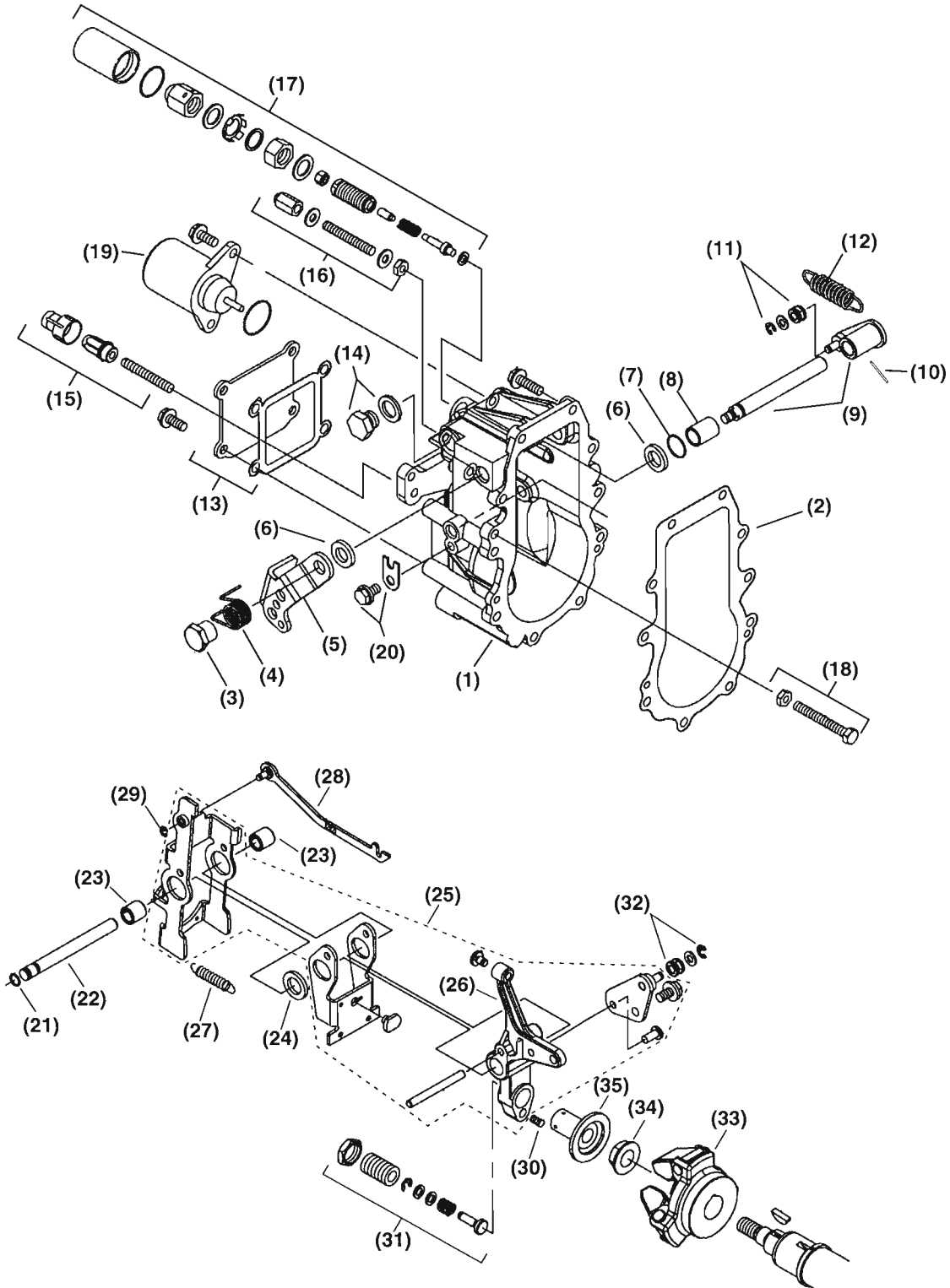

Figure 4-2

**GOVERNOR COMPONENTS (MP2 / MP4 MODELS)**

- |  |   |   |
|--|---|---|
| 1. Governor Housing                              | 15. High Idle Speed Adjustment<br>Screw       | 25. Governor Lever Assembly   |
| 2. Governor Housing Gasket                       | 16. Starting Fuel Adjustment<br>Screw         | 26. Governor Tension Lever<br>(Included in Governor Lever<br>Assembly.) |
| 3. Control Lever Lock Nut                        | 17. Rated Fuel Limiter Assembly               | 27. Governor Lever Assembly<br>Spring                                   |
| 4. Control Lever Return Spring                   | 18. Low Idle Speed Adjustment<br>Screw        | 28. Governor Link   |
| 5. Control Lever                                 | 19. Stop Solenoid                             | 29. Governor Link Retainer Clip   |
| 6. Control Lever Shaft Shim                      | 20. Governor Lever Shaft<br>Retainer and Bolt | 30. Excess Fuel Spring  |
| 7. Control Lever Shaft O-Ring                    | 21. Governor Lever Shaft O-Ring               | 31. Angleich Spring Assembly  |
| 8. Control Lever Shaft Spacer                    | 22. Governor Lever Shaft                      | 32. Governor Spring - Clip,<br>Washer and Roller                        |
| 9. Control Lever Shaft                           | 23. Governor Lever Assembly<br>Bushing        | 33. Governor Weight Assembly  |
| 10. Control Lever Shaft Pin                      | 24. Governor Lever Assembly<br>Spacer         | 34. Governor Weight Nut   |
| 11. Governor Spring - Clip,<br>Washer and Roller |   | 35. Governor Sleeve   |
| 12. Governor Spring                              |   |   |
| 13. Housing Cover and Seal                       |   |   |
| 14. Lubricant Fill Plug and Seal                 |   |   |

*Figure 4-3*

# GOVERNOR TORQUE SPECIFICATIONS (MP2 / MP4 MODELS)

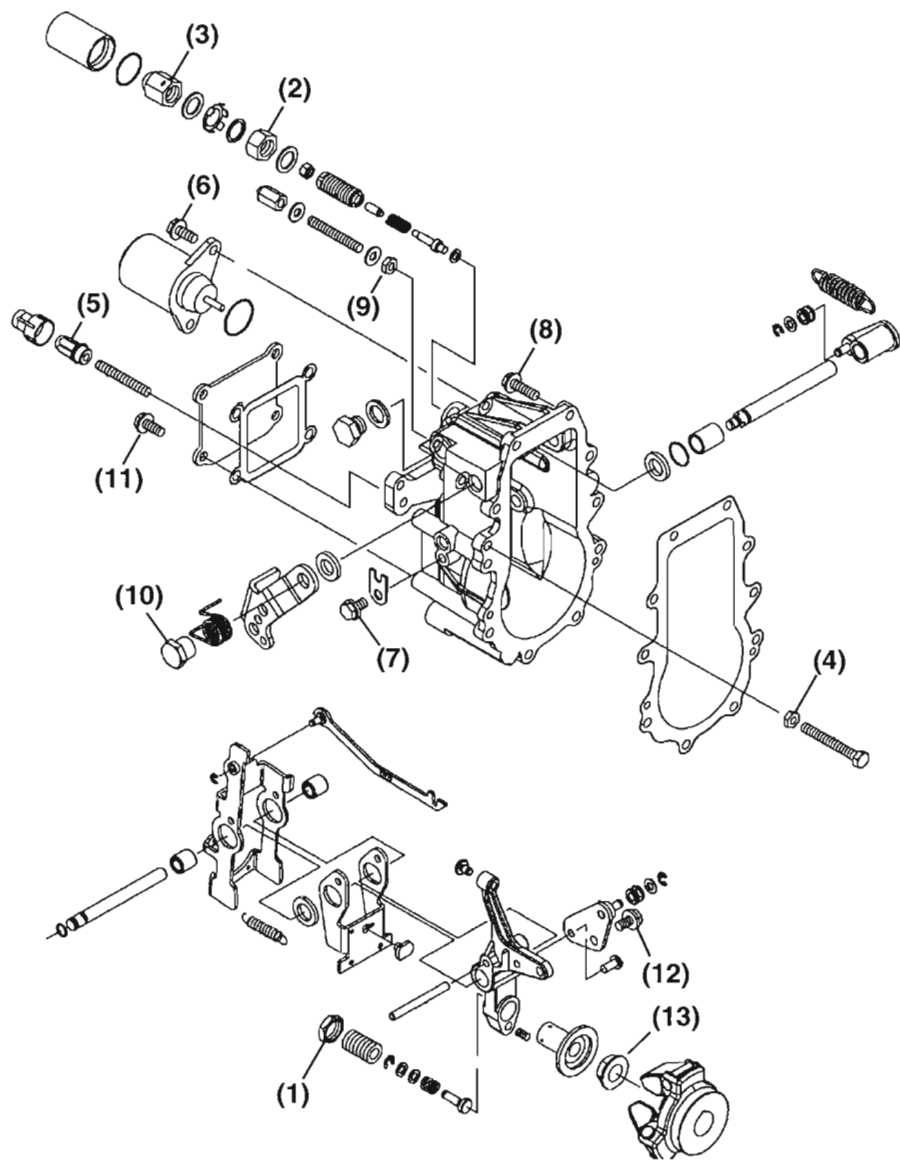

Figure 4-4

0003465C

## GOVERNOR TORQUE SPECIFICATIONS (MP2 / MP4 MODELS)

No.	Item	Tightening Torque		No.	Item	Tightening Torque	
		MP2 / MP4				MP2 / MP4	
1	Angleich Lock Nut	18 - 21 ft-lb (25 - 29 N·m)		8	Governor Housing Bolt	6 - 7 ft-lb (8 - 10 N·m)	
		M14x1				M6x1	
2	Rated Fuel Limiter Lock Nut	15 - 16 ft-lb (20 - 22 N·m)		9	Starting Fuel Adjustment Lock Nut	6 - 7 ft-lb (8 - 10 N·m)	4 - 6 ft-lb (6 - 8 N·m)
		M12x1.25				M6x1	M5x0.8
3	Rated Fuel Limiter Cap Nut	15 - 16 ft-lb (20 - 22 N·m)		10	Control Lever Lock Nut	15 - 16 ft-lb (20 - 22 N·m)	
		M12x1.25			Lever Side Clearance	0.001 - 0.002 in. (0.3 - 0.6 mm)	
4	Low Idle Speed Lock Nut	6 - 7 ft-lb (8 - 10 N·m)		11	Cover Bolt	6 - 7 ft-lb (8 - 10 N·m)	
		M6x1				M6x1	
5	High Idle Speed Lock Nut	3 - 7 ft-lb (8 - 10 N·m)		12	Governor Tension Lever Retainer Bolts	4 - 6 ft-lb (6 - 8 N·m)	
		M6x1				M6x1	
6	Stop Solenoid Bolt	6 - 7 ft-lb (8 - 10 N·m)		13	Governor Weight Nut	59 - 62 ft-lb (79 - 84 N·m)	
		M6x1				M12x1.25	
7	Governor Lever Shaft Retainer Bolt	6 - 7 ft-lb (8 - 10 N·m)					
		M6x1					
	Lever Side Clearance	0.001 - 0.002 in. (0.3 - 0.6 mm)					



# GOVERNOR

## GOVERNOR SERVICE

### Removal

Note: Keep parts in order during disassembly to ensure proper assembly.

1. Mount the fuel pump and governor assembly to a repair stand (**Figure 4-5**).

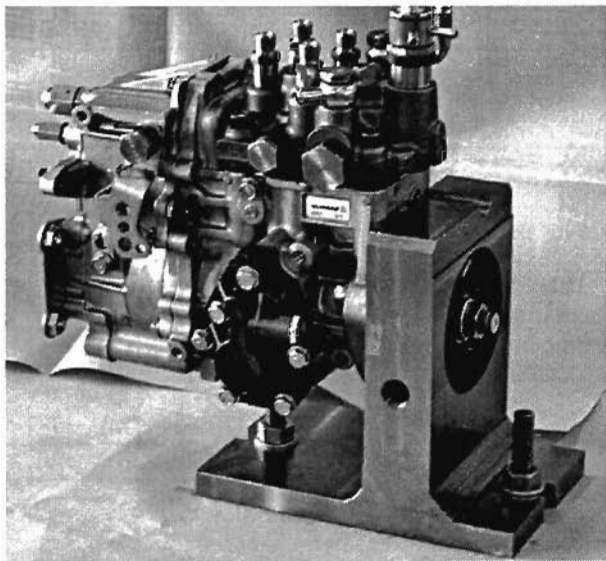

0001170a

**Figure 4-5**

2. Remove the link lifter plate bolt (**Figure 4-6, (1)**).

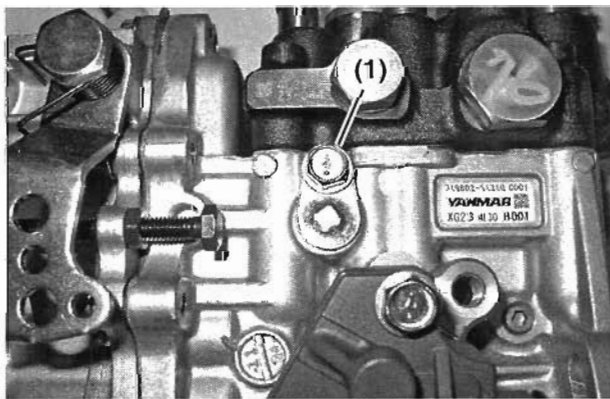

0001171a

**Figure 4-6**

3. Turn the link lifter plate (**Figure 4-7**) counterclockwise 180 degrees to the 6 o'clock position to disengage the governor link (**Figure 4-7, (1)**) from the control rack.

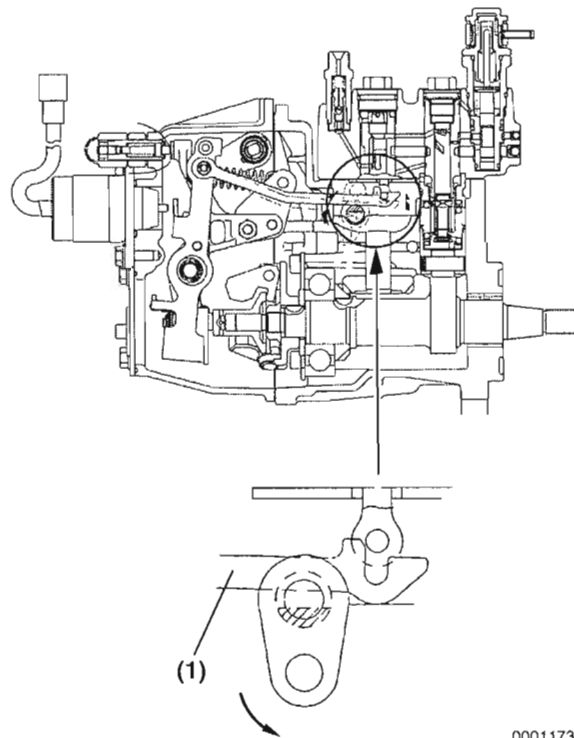

0001173

**Figure 4-7**

4. Remove the bolts from the governor housing (**Figure 4-8, (2)**) and remove the governor assembly from the fuel pump body (**Figure 4-8, (1)**).



0001174a

**Figure 4-8**



## Disassembly

1. Remove the governor housing cover from the governor housing (**Figure 4-9**).

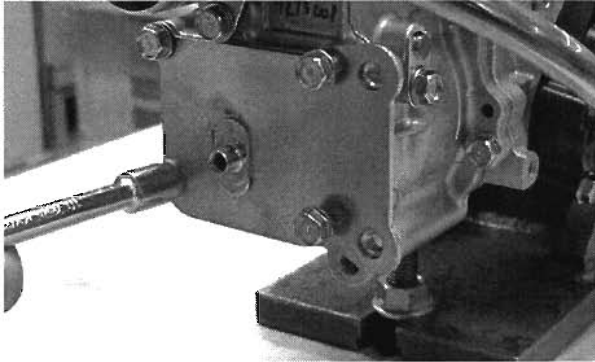

0001308a

**Figure 4-9**

2. Remove the governor housing cover gasket and discard (**Figure 4-10, (1)**).

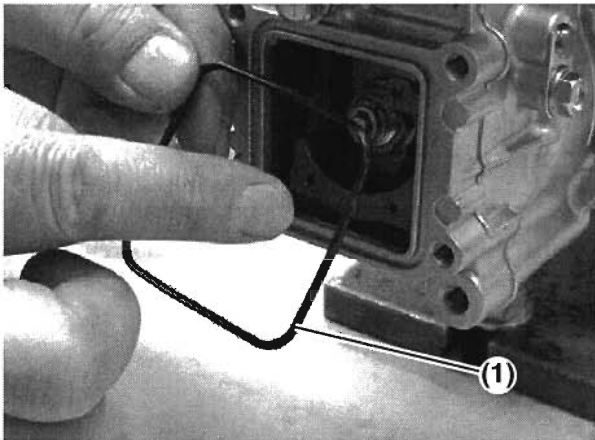

0001307a

**Figure 4-10**

3. Remove the stop solenoid and O-ring (**Figure 4-11, (1)**).

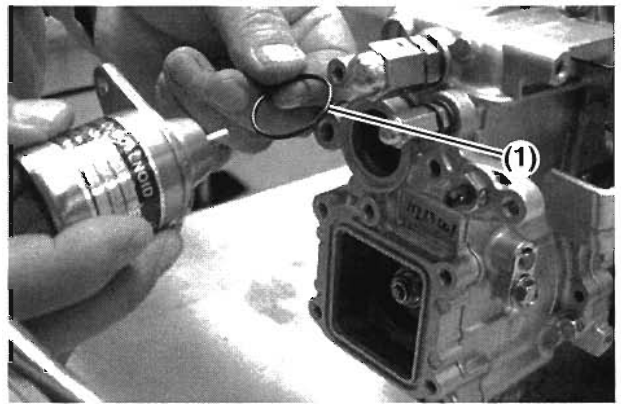

0001306a

**Figure 4-11**

4. Remove the control lever lock nut (**Figure 4-12, (1)**), control lever return spring (**Figure 4-12, (2)**) and control lever (**Figure 4-12, (3)**).

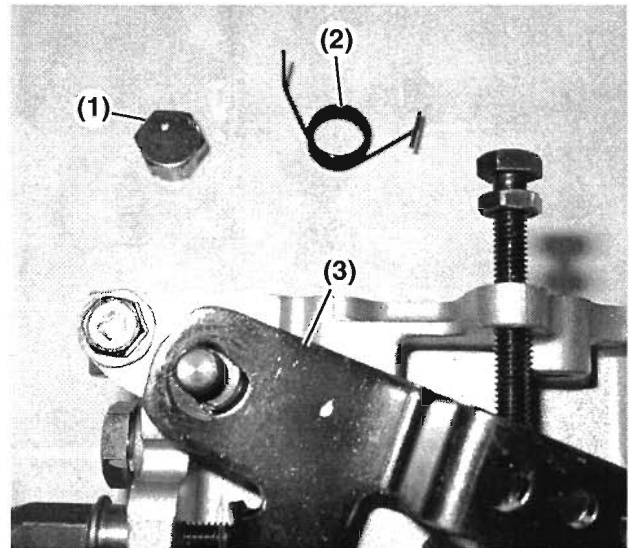

0001222b

**Figure 4-12**

## GOVERNOR

- Remove the control lever shaft retainer bolt (**Figure 4-13, (1)**) and retainer (**Figure 4-13, (2)**).

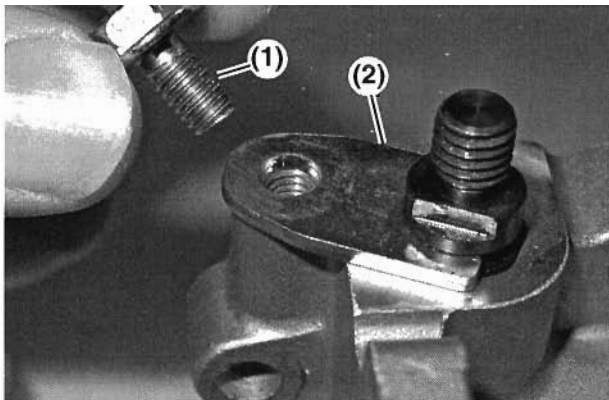

0004258

**Figure 4-13**

- Remove the control lever shaft shim (**Figure 4-14, (1)**).

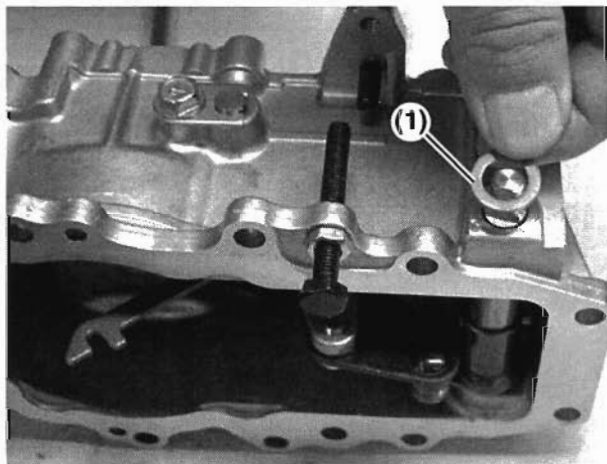

0001296a

**Figure 4-14**

Note: Be careful to not stretch, twist or deform the governor spring during removal.

- Remove the governor spring (**Figure 4-15, (1)**) from the control lever shaft and governor tension lever.

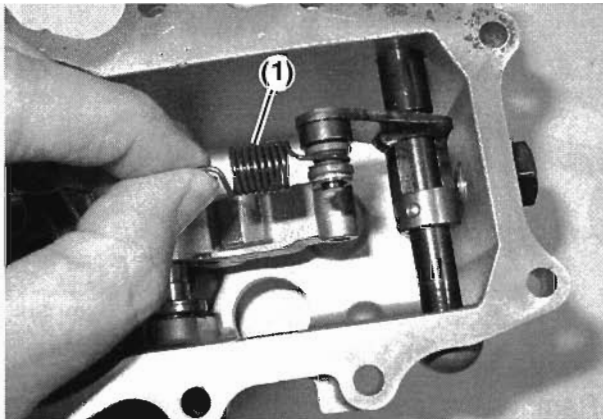

0001229b

**Figure 4-15**

Note: Before removing the control lever shaft, scribe an alignment mark on the two mating parts of the control lever shaft to assist in reassembly.

- Remove the control lever shaft pin (**Figure 4-16, (2)**) from the control lever shaft. Then remove the control lever shaft assembly (**Figure 4-16, (1)**), O-ring (**Figure 4-16, (4)**) and bushing (**Figure 4-16, (3)**).

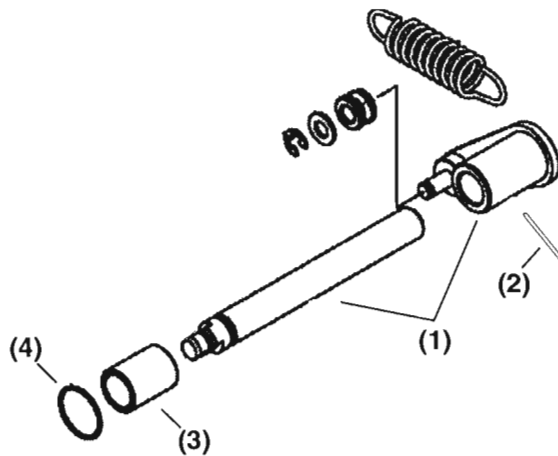

**Figure 4-16**

- Remove the governor lever shaft retainer bolt (Figure 4-17, (1)) and retainer (Figure 4-17, (2)).

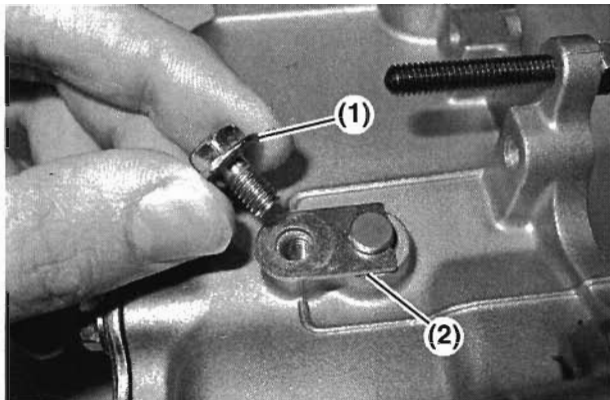

0001225b

Figure 4-17

Note: Before removing the governor lever shaft (Figure 4-18, (1)), mark the positions of the governor lever assembly spacer (Figure 4-18, (4)) and bushings (Figure 4-18, (3)), to ensure proper reassembly of the governor lever assembly (Figure 4-18, (2)) and governor lever tension arm (Figure 4-18, (5)).

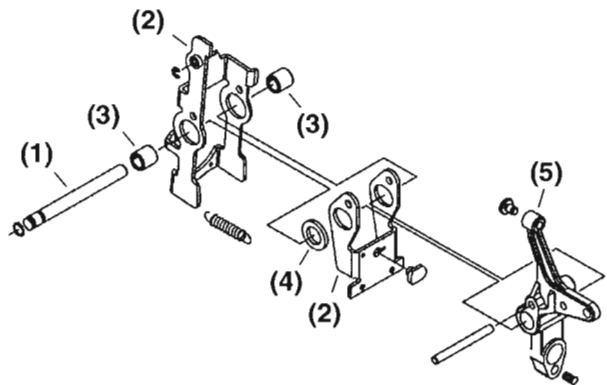

0004083a

Figure 4-18

- Remove the governor lever shaft (Figure 4-19).

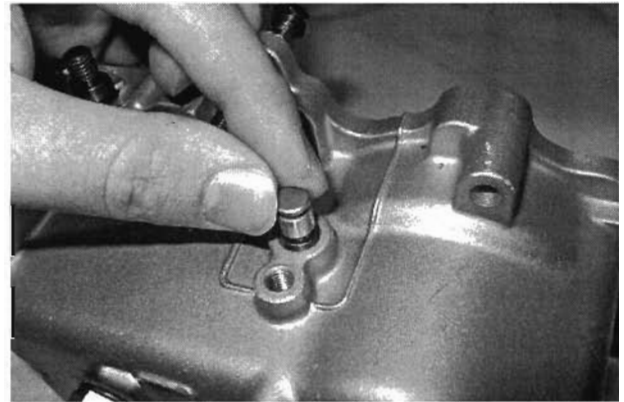

0001226b

Figure 4-19

- Remove the governor lever (Figure 4-20, (1)) assembly and governor tension lever.

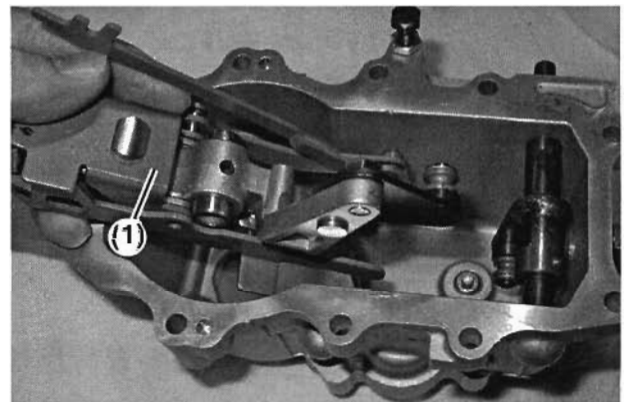

0001228a

Figure 4-20



## GOVERNOR

12. To remove the governor weight, attach a stop to the camshaft (**Figure 4-21**).

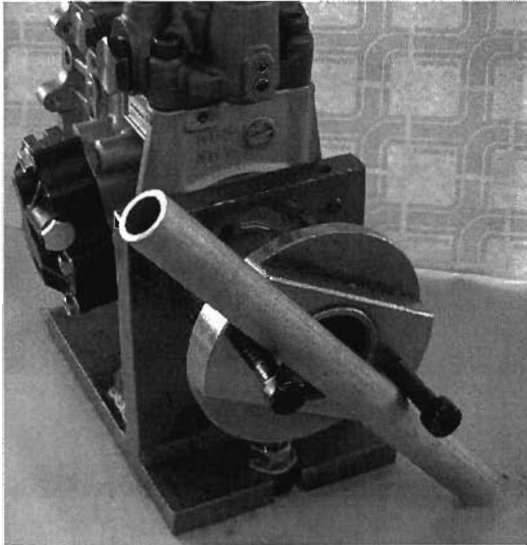

0001177a

**Figure 4-21**

13. Remove the governor sleeve. Then remove the governor weight assembly retaining nut (**Figure 4-22**) and weight assembly from the fuel injection pump camshaft.

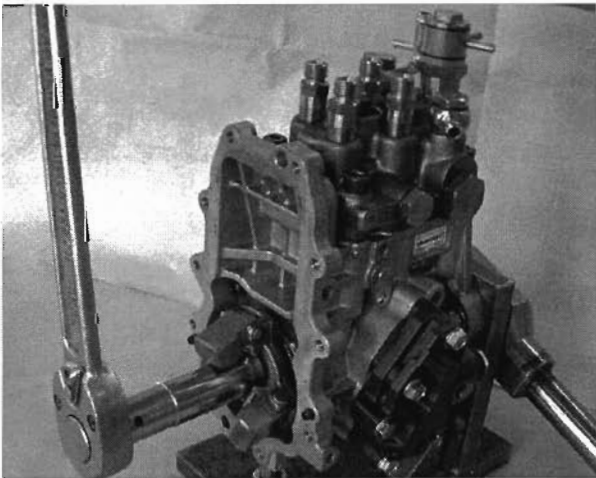

0001178a

**Figure 4-22**

## Assembly

Note: Inspect all parts for wear or damage, replace as necessary. Clean all parts (**Figure 4-23**) before assembling.

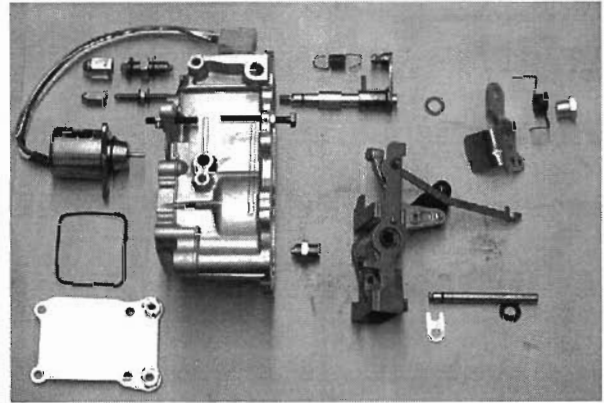

0001292

**Figure 4-23**

1. Inspect the governor tension lever (**Figure 4-24, (1)**), governor lever assembly (**Figure 4-24, (2)**), excess fuel spring (**Figure 4-24, (3)**), angleich spring assembly (**Figure 4-24, (4)**), governor sleeve (**Figure 4-24, (5)**) and governor weight assembly (**Figure 4-24, (6)**) for wear. Replace components as necessary.

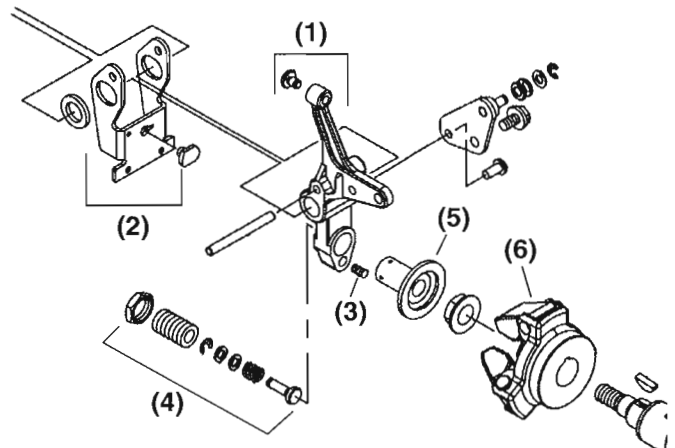

**Figure 4-24**

2. Inspect the governor link (**Figure 4-25, (1)**), governor lever shaft (**Figure 4-25, (2)**), governor lever bushings (**Figure 4-25, (3)**), governor lever assembly (**Figure 4-25, (4)**) and governor lever spring (**Figure 4-25, (5)**) for wear. Replace components as necessary.

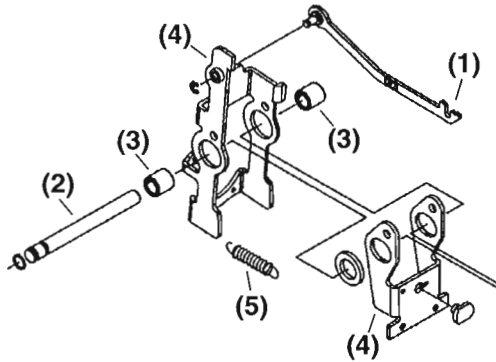

0004083

**Figure 4-25**

3. Insert the governor lever shaft (**Figure 4-26, (1)**) through the governor housing, governor bushings (**Figure 4-26, (3)**), shim (**Figure 4-26, (4)**), governor lever assembly (**Figure 4-26, (2)**), governor lever tension arm (**Figure 4-26, (5)**) and spacer.

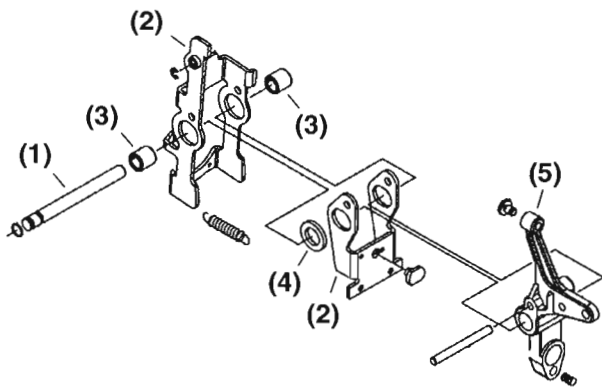

0004083a

**Figure 4-26**

4. Install the governor lever shaft retainer and tighten the retainer bolt (**Figure 4-27, (1)**) to 6 -7 ft-lb. (8 -10 N·m).

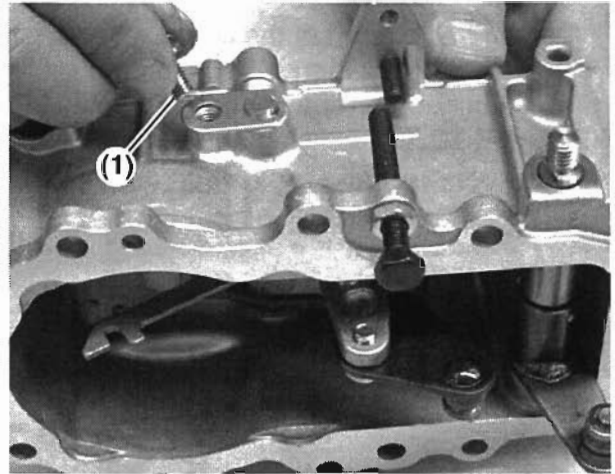

0001295a

**Figure 4-27**

5. Check the governor tension lever side clearance (**Figure 4-28**) and adjust to 0.0001 - 0.0002 in. (0.3 - 0.6mm).

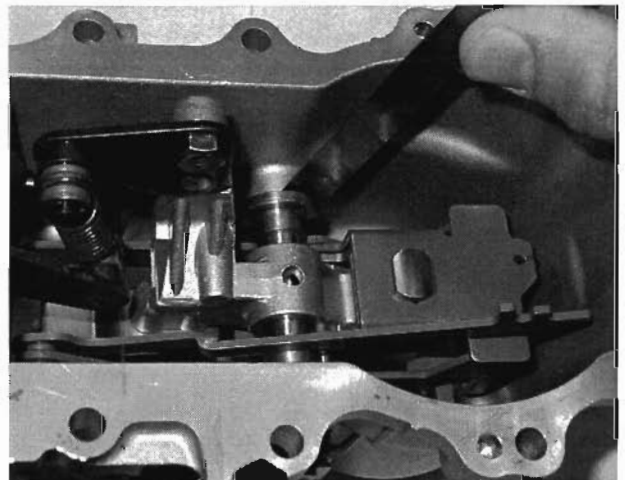

0004259

**Figure 4-28**

## GOVERNOR

6. Install the control lever shaft (**Figure 4-29, (1)**) through the governor housing, control lever shaft bushing (**Figure 4-29, (3)**) and into the mating part of the control lever shaft.
7. Align the mating part of the control lever shaft with the alignment marks made during disassembly. Install the control lever shaft pin (**Figure 4-29, (2)**) to fasten the two parts.
8. Install the O-ring (**Figure 4-29, (4)**) on the governor lever shaft.

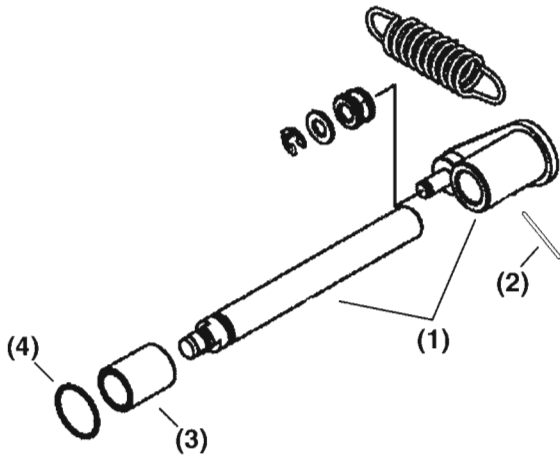

**Figure 4-29**

9. Install the control lever shaft shim (**Figure 4-30, (1)**).

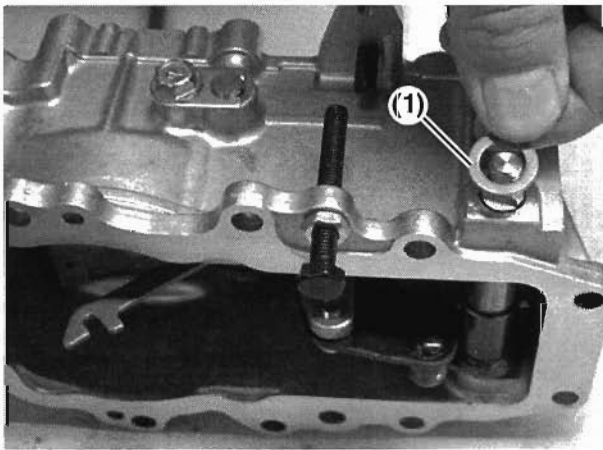

0001296a

**Figure 4-30**

10. Install the control lever (**Figure 4-31, (1)**).

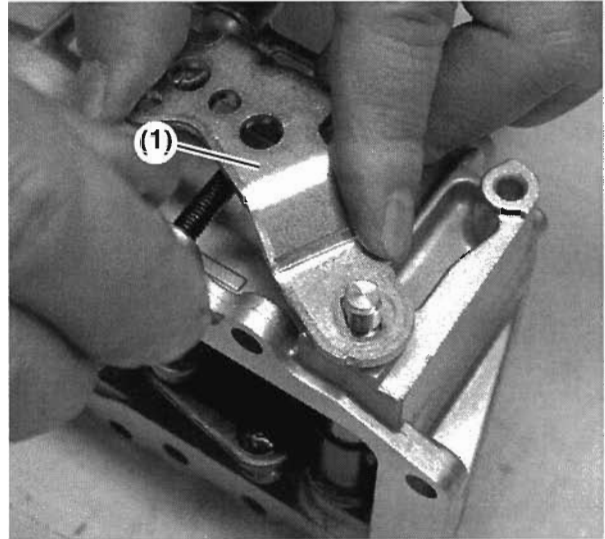

0001297a

**Figure 4-31**

11. Insert the control lever return spring (**Figure 4-32, (2)**) through the control lever lock nut (**Figure 4-32, (1)**) and attach as shown.

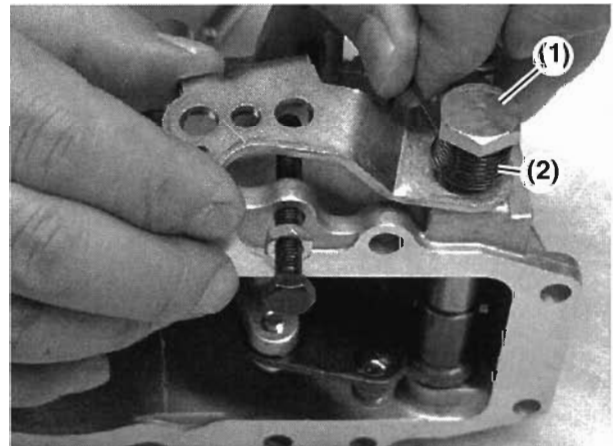

0001298a

**Figure 4-32**



12. Tighten the control lever lock nut to 15 -16 ft-lb. (20 - 22 N·m).
13. Measure the side clearance with a feeler gauge (**Figure 4-33, (1)**). Clearance must be 0.001 - 0.002 in. (0.3 - 0.6 mm). Add or remove shims to achieve the proper clearance.

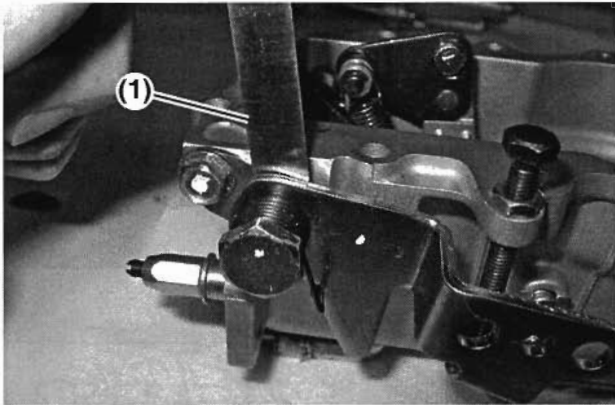

0004082A

**Figure 4-33**

Note: Be careful to not stretch, twist or deform the governor spring during installation.

14. Install the governor spring (**Figure 4-34, (1)**) to the control lever shaft and governor tension lever.

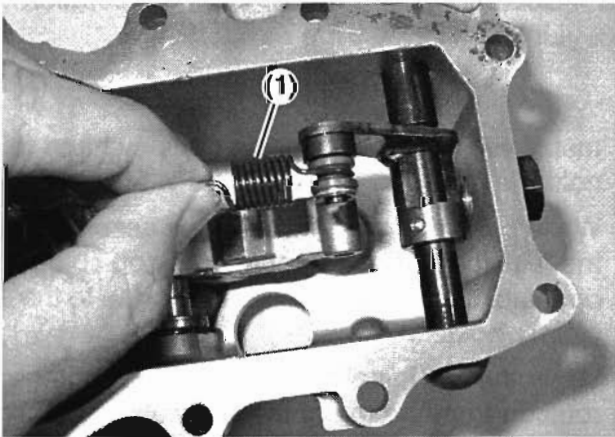

0001229b

**Figure 4-34**

## Installation

1. Install the governor weight assembly and nut (**Figure 4-35, (1)**) to the fuel injection pump camshaft.



0001250a

**Figure 4-35**

2. Attach a stop to the camshaft. Tighten the governor weight nut (**Figure 4-36, (1)**) to 58 - 62 ft-lb. (79 - 84 N·m). Install the governor sleeve.

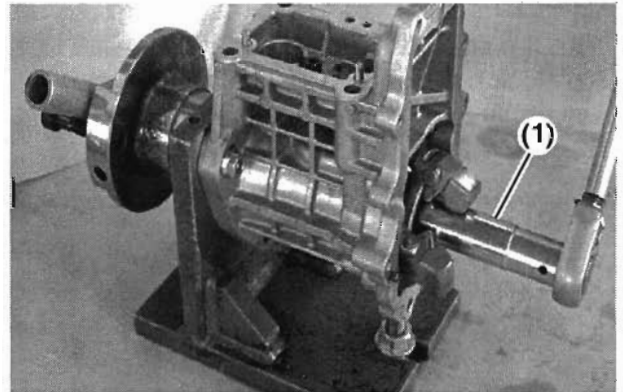

0001251a

**Figure 4-36**

# GOVERNOR

Note: Be careful not to bend or damage the governor housing gasket.

3. Align and install a new governor housing gasket (**Figure 4-37, (1)**).

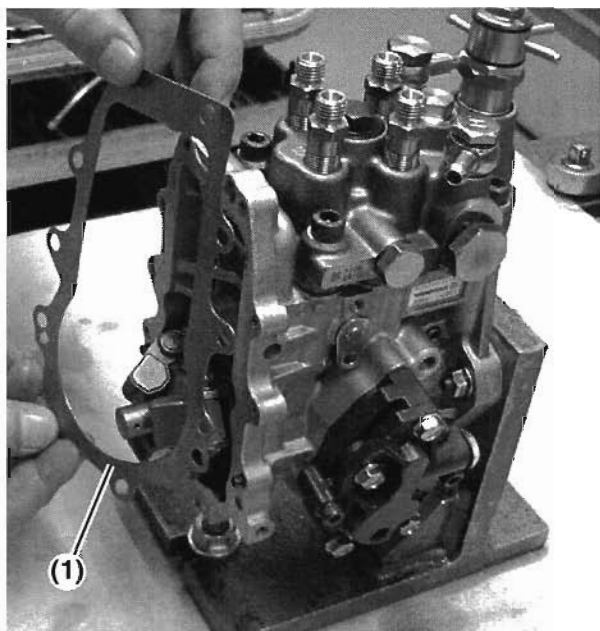

0001300a

**Figure 4-37**

4. Turn the link lifter plate counterclockwise to the 6 o'clock position and install the governor assembly and link into the pump body (**Figure 4-38**).

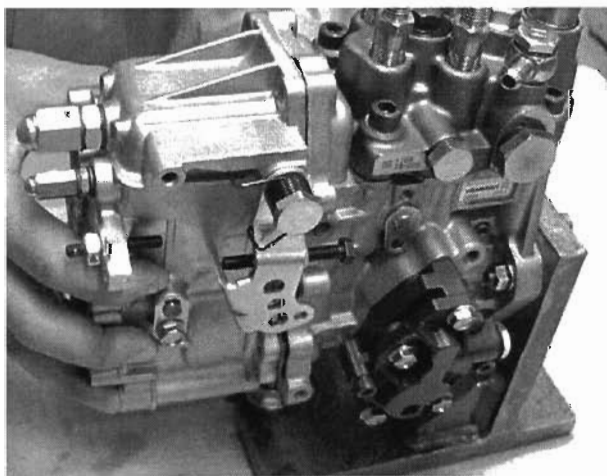

0001302a

**Figure 4-38**

Note: Do not force the link during installation, as damage can occur to the link and control rack pin.

Note: **Figure 4-39** illustrates the governor link connection to the control rack. The actual connection is blind, therefore this illustration is used to assist during assembly.

5. While installing the governor assembly, slide the link lifter as shown (**Figure 4-39, 4**), to allow the link to slide in to align with the control rack pin.

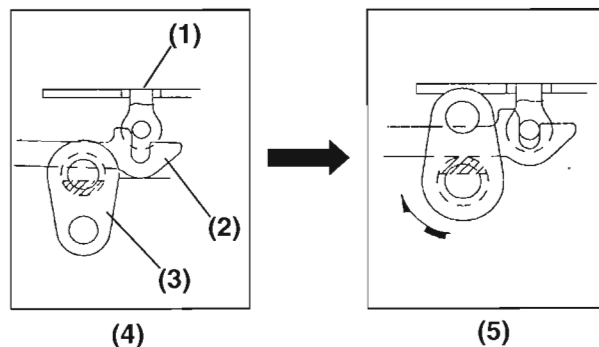

0001301

- |                  |                     |
|------------------|---------------------|
| 1. Control Rack  | 4. During Assembly  |
| 2. Governor Link | 5. During Operation |
| 3. Link Lifter   |                     |

**Figure 4-39**

6. Install two governor housing bolts by hand to hold the governor in place.
7. While pushing the governor lever assembly to the full stop position through the stop solenoid opening, rotate the link lifter clockwise to the 12 o'clock position.
8. Verify the link installation by watching plunger rotation from the top of the hydraulic head. The plunger should rotate in both directions while moving the control rack in and out.



9. Tighten the link lifter retainer bolt (**Figure 4-40, (1)**) to 6 - 7 ft-lb (8 - 10 N·m).

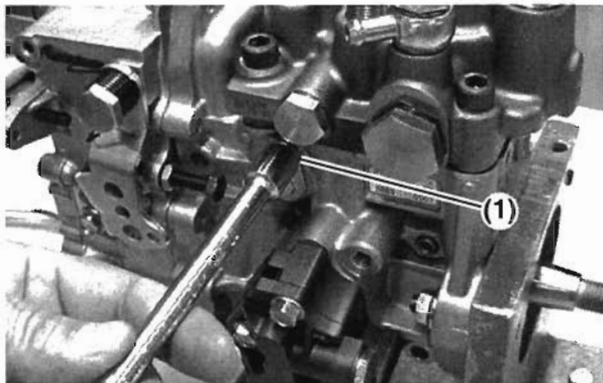

0001304a

**Figure 4-40**

10. Install all the governor housing screws and tighten to 6 - 7 ft-lb (8 - 10 N·m) (**Figure 4-41**).

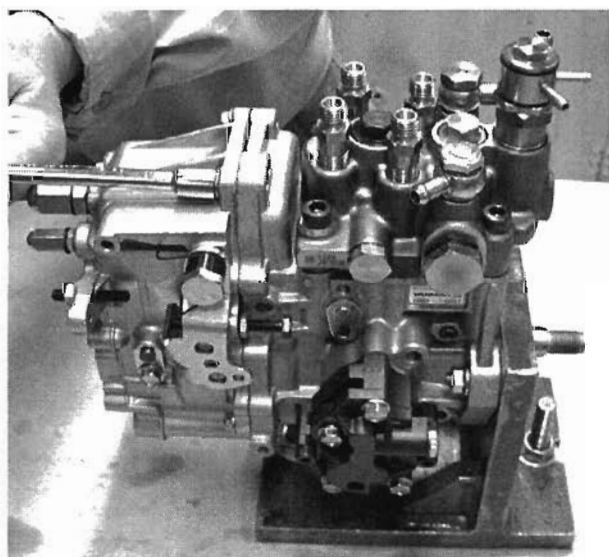

0001305a

**Figure 4-41**

11. Install a new O-ring (**Figure 4-42, (1)**) to the stop solenoid and install the stop solenoid to the governor housing. Tighten the solenoid bolts to 6 - 7 ft-lb (8 - 10 N·m).

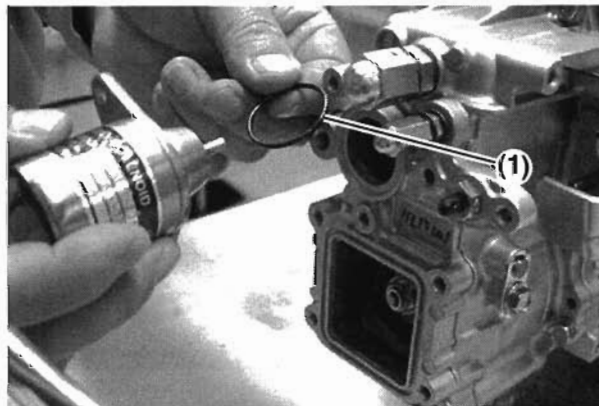

0001306a

**Figure 4-42**

12. Pre-set the adjustment of the angleich assembly by loosening the angleich lock nut (**Figure 4-43, (1)**).

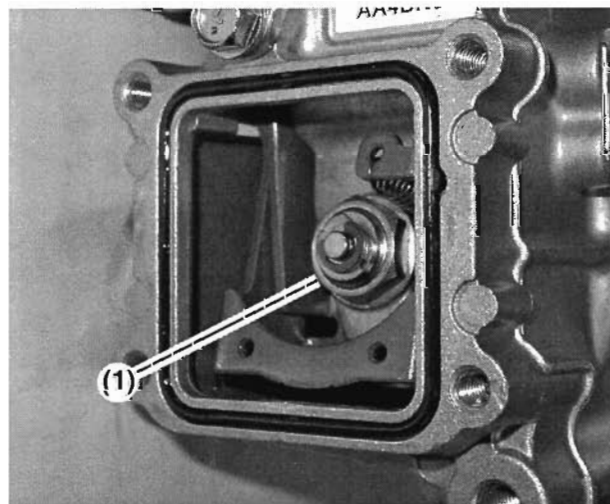

0001306C

**Figure 4-43**

13. Turn the angleich adjustment screw in until it contacts the governor lever and then back out one-quarter (0.25) turn.
14. Tighten the angleich lock nut.

## GOVERNOR

---

15. Install a new governor housing cover gasket (Figure 4-44).

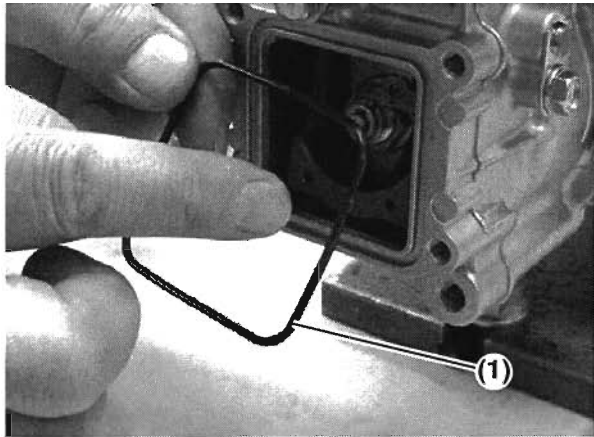

**Figure 4-44**

16. Install the governor housing cover to the case (Figure 4-45). Tighten the governor housing cover bolts to 6 - 7 ft-lb (8 - 10 N·m).

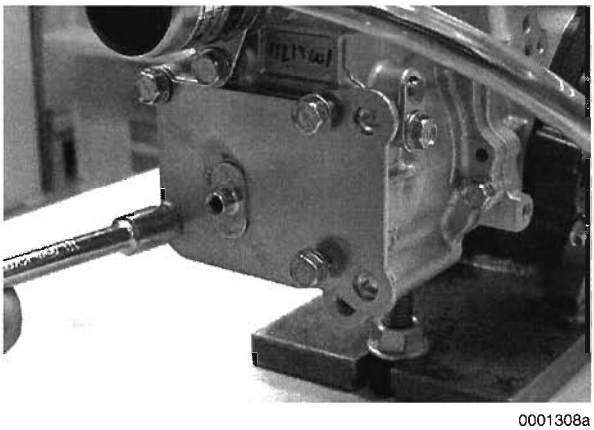

**Figure 4-45**

## Section 5

# FUEL INJECTION PUMP

---

	Page
Introduction.....	5-3
Specifications .....	5-3
Pump Torque Specifications (MP2 / MP4 Models).....	5-4
Pump Torque Specifications (MP2 / MP4 Models).....	5-5
Special Tools.....	5-6
MP-Fuel Pump Components .....	5-7
MP-Fuel Pump Components .....	5-8
Fuel Flow.....	5-9
Fuel Flow Diagram .....	5-10
Charge Pump .....	5-11
Specifications .....	5-11
Timer Control Mechanisms .....	5-12
Speed Timer Function .....	5-12
Load Timer Function.....	5-13
Cold Start Timer .....	5-14
Fuel Pump Disassembly.....	5-15
Governor.....	5-15
Charge Pump .....	5-16
Hydraulic Head.....	5-18
Distribution Shaft, Camshaft and Roller Lifter Removal .....	5-22
Fuel Pump Reassembly .....	5-24
Distribution Shaft and Camshaft.....	5-24
Gear Alignment.....	5-26
Roller Lifter .....	5-27
Plunger and Control Rack .....	5-27
Hydraulic Head and Valve(s) Reassembly.....	5-32
Charge Pump .....	5-34
Governor Installation .....	5-35

## FUEL INJECTION PUMP

---

**This Page Intentionally Left Blank**

## INTRODUCTION

This section of the *Service Manual* describes the operation and procedures necessary to disassemble, inspect and reassemble the fuel injection pump.

The primary components of the Yanmar MP fuel injection pump consists of a governor assembly, single plunger style hydraulic head assembly, distribution shaft and gears, individual cylinder fuel delivery valves, camshaft and pump housing.

## SPECIFICATIONS

Model	3MP2	4MP2	4MP4
Applicable Engine	3TNV82A/84(T)/88	4TNV84(T)/88	4TNV94/98(T)106(T)
Plunger Diameter	0.35 in (9 mm)		0.40 in (10 mm)
Max. Cam Lift	0.32 in (8.1 mm)		0.40 in (10 mm)
Governor-System	Mechanical All Speed Governor		
Fuel Injection Timing Control System	Built-in Hydraulic Control Timer		
Fuel Feed Pump	Trochoid Gear Charge Pump		
Lubrication System	Engine Oil		
Dry Weight	18.5 lb (8.4 kg)	19.0 lb (8.6 kg)	25.4 lb (11.5 kg)

# FUEL INJECTION PUMP

## PUMP TORQUE SPECIFICATIONS (MP2 / MP4 MODELS)

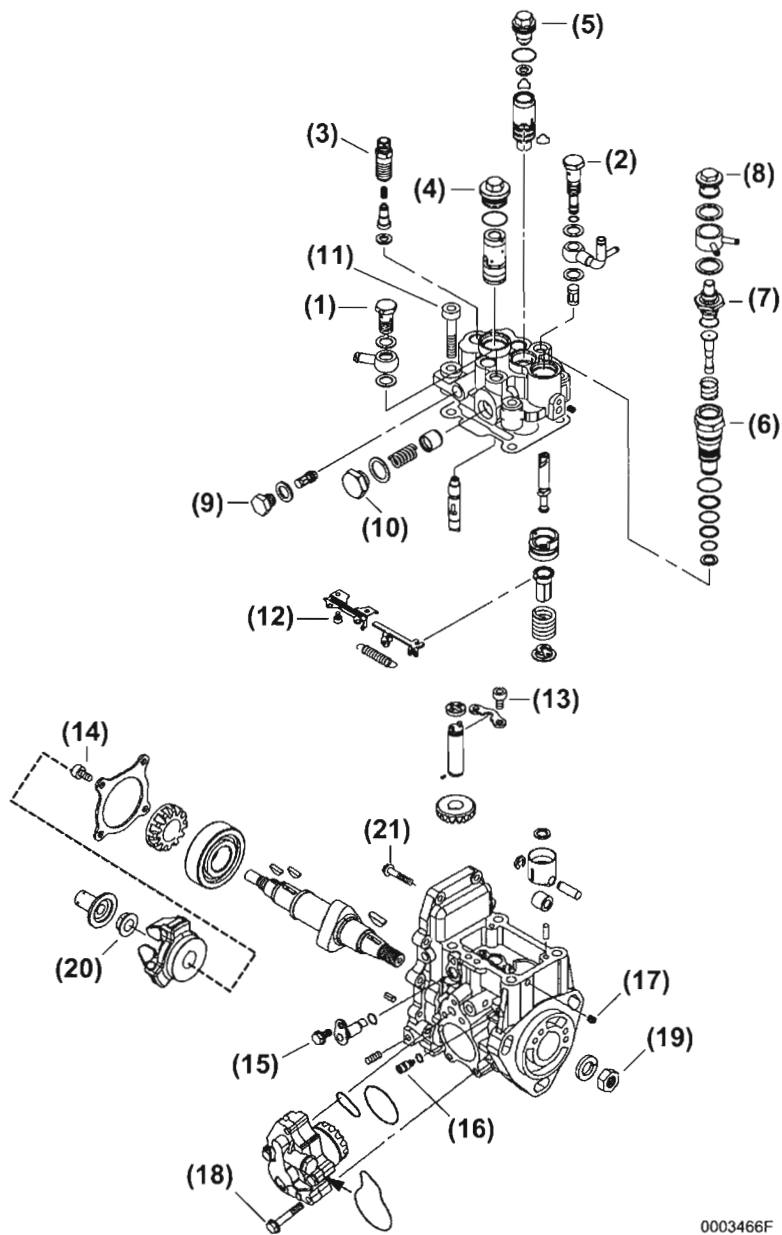

0003466F

Figure 5-1

**PUMP TORQUE SPECIFICATIONS (MP2 / MP4 MODELS)**

No.	Item	Tightening Torque		No.	Item	Tightening Torque	
		MP2 / MP4				MP2 / MP4	
1	Fuel Inlet Fitting	18 - 21 ft-lb (25 - 29 N·m)		12	Control Rack Guide Retaining Screw	2 - 3 ft-lb (3 - 4 N·m)	
		M12x1.25				M4x0.7 (hexagon socket head)	
2	Fuel Return Fitting	18 - 21 ft-lb (25 - 29 N·m)		13	Distribution Shaft Retainer Screw	6 - 7 ft-lb (8 - 10 N·m)	
		M12x1.25				M6x1 (hexagon socket head)	
3	Delivery Valve Housing	30 - 33 ft-lb (40 - 45 N·m)		14	Camshaft Bearing Retainer Bolt	6 - 7 ft-lb (8 - 10 N·m)	
		M14x1.25				M6x1 (hexagon socket head)	
4	Distribution Shaft Plug	11 ft-lb (15 N·m)		15	Governor Link Retainer Shaft Screw	6 - 7 ft-lb (8 - 10 N·m)	
		M22x1				M6x1	
5	Plunger and Barrel Plug	22 - 26 ft-lb (30 - 35 N·m)	33 - 37 ft-lb (45 - 50 N·m)	16	Roller Lifter Alignment Pin	3 - 4 ft-lb (4 - 5 N·m)	
		M14x1	M16x1			M6x1(hexagon socket head)	
		Early - M18X1, 37 - 41 ft-lb (50-55 N·m)					
6	Timer Holder	30 - 33 ft-lb (40 - 45 N·m)		17	Control Rack Plug	3 - 4 ft-lb (4 - 5 N·m)	
		M22x1				M6x1	
7	Thermo Element	22 - 26 ft-lb (30 - 35 N·m)		18	Charge Pump Bolts	6 - 7 ft-lb (8 - 10 N·m)	
		M16x1				M6x1	
8	Coolant Water Plug	16 - 18 ft-lb (22 - 25 N·m)		19	Camshaft Drive Nut	58 - 65 ft-lb (78 - 88 N·m)	83 - 91 ft-lb (113 - 123 N·m)
		M14x1				M14x1.5	M18x1.5
9	Charge Pump Fuel Outlet Strainer Plug	16 - 21 ft-lb (25 - 29 N·m)		20	Governor Weight Nut	59 - 62 ft-lb (79 - 84 N·m)	
		M12x1.25				M12x1.25	
10	Accumulator Plug	37 - 41 ft-lb (50 - 55 N·m)		21	Governor Housing Screw	6 - 7 ft-lb (8 - 10 N·m)	
		M20x1				M6x1	
11	Hydraulic Head Bolt	13 - 16 ft-lb (18 - 22 N·m)	21 - 24 ft-lb (28 - 32 N·m)				
		M8x1.25 (hexagon socket head)	M10x1.5 (hexagon socket head)				



# FUEL INJECTION PUMP

## SPECIAL TOOLS

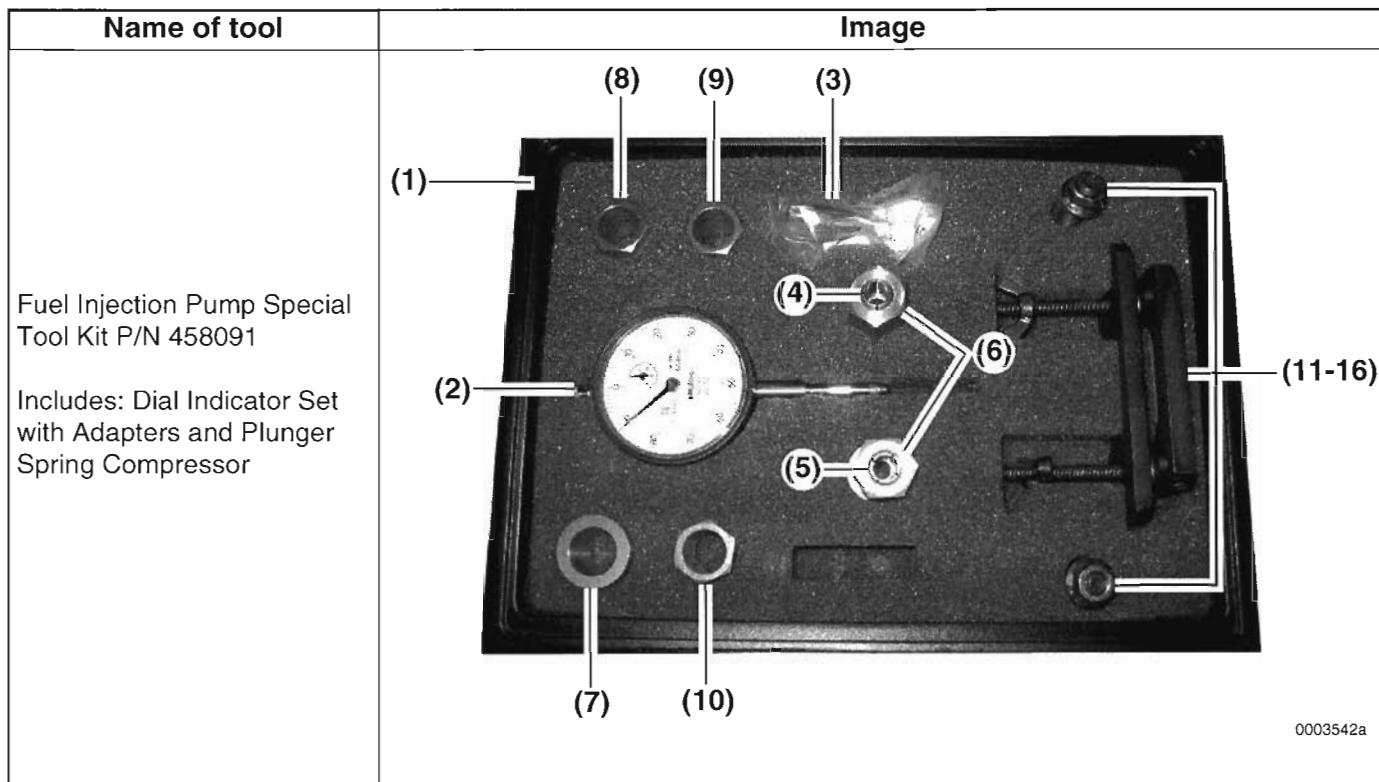

0003542a

No.	Item	Yanmar Part No.	Qty.
1	Carrying Case	15809000	1
2	Dial Indicator	15809001	1
3	30 mm Extension Rod	15809002	1
4	M14 Adapter	15809003	1
5	M16 Adapter	15809004	1
6	Adapter Nut	15809005	2
7	Lift Gauge, 28.55 mm	15809007	1
8	Lift Gauge, 25.5 mm	15809008	1
9	Lift Gauge, 25.9 mm	15809009	1
10	Lift Gauge, 26.3 mm	15809010	1
11 - 16	Base Spring Compressor	15809011	1
	Top, Spring Compressor	15809012	1
	Rod, Spring Compressor	15809013	2
	U-Nut, M8	26366-080002	2
	Bolt, M8x50	26450-080502	2
	Wing Nut M6	26636-060002	2



MP-FUEL PUMP COMPONENTS

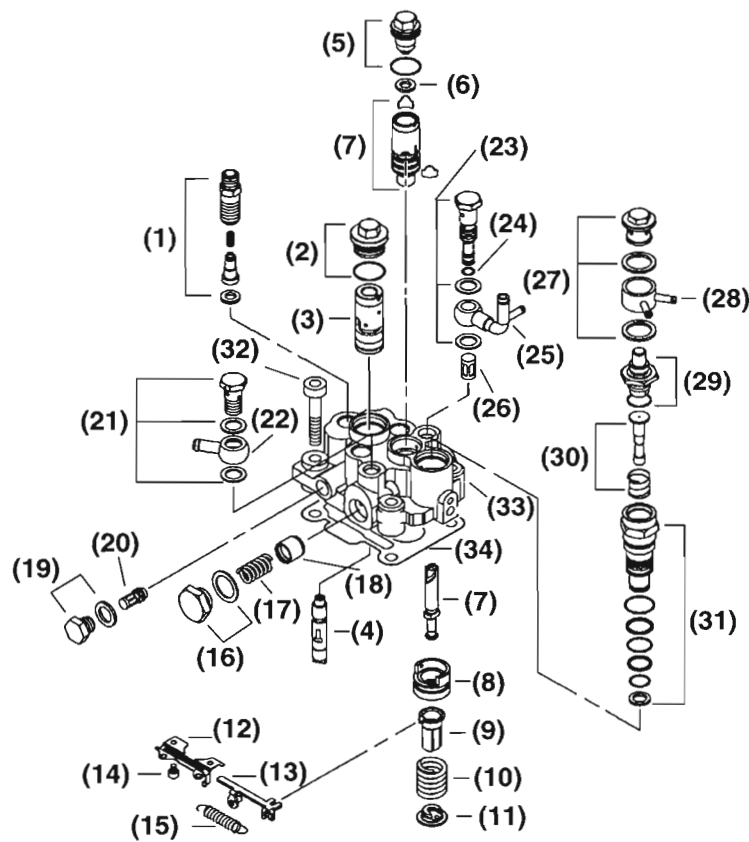

0003466A

- |                                       |  |                                       |
|---------------------------------------|--|---------------------------------------|
| 1. Delivery Valve Assembly            | 13. Control Rack                                     | 23. Fuel Return Fitting and Seals     |
| 2. Distribution Shaft Plug and O-Ring | 14. Control Rack Retaining Screw                     | 24. Fuel Return Fitting Strainer Seal |
| 3. Distribution Shaft Sleeve          | 15. Control Rack Spring                              | 25. Fuel Return Pipe                  |
| 4. Distribution Drive Shaft           | 16. Accumulator Plug and O-Ring                      | 26. Fuel Return Strainer              |
| 5. Plunger and Barrel Plug and O-Ring | 17. Accumulator Spring                               | 27. Coolant Water Plug and Seals      |
| 6. Plunger and Barrel Seal            | 18. Accumulator Piston                               | 28. Coolant Water Fitting             |
| 7. Plunger and Barrel Assembly        | 19. Charge Pump Outlet Fuel Strainer Plug and O-Ring | 29. Thermo-Element                    |
| 8. Plunger Spring Cup                 | 20. Charge Pump Outlet Fuel Strainer                 | 30. Timer Piston and Spring           |
| 9. Plunger Spring Sleeve              | 21. Fuel Inlet Pipe and Seals                        | 31. Timer Housing and Seals           |
| 10. Plunger Spring                    | 22. Fuel Inlet Fitting                               | 32. Head Bolt                         |
| 11. Plunger Spring Retainer           |  | 33. Hydraulic Head                    |
| 12. Control Rack Guide                |  | 34. Hydraulic Head Gasket             |

Figure 5-2

## MP-FUEL PUMP COMPONENTS

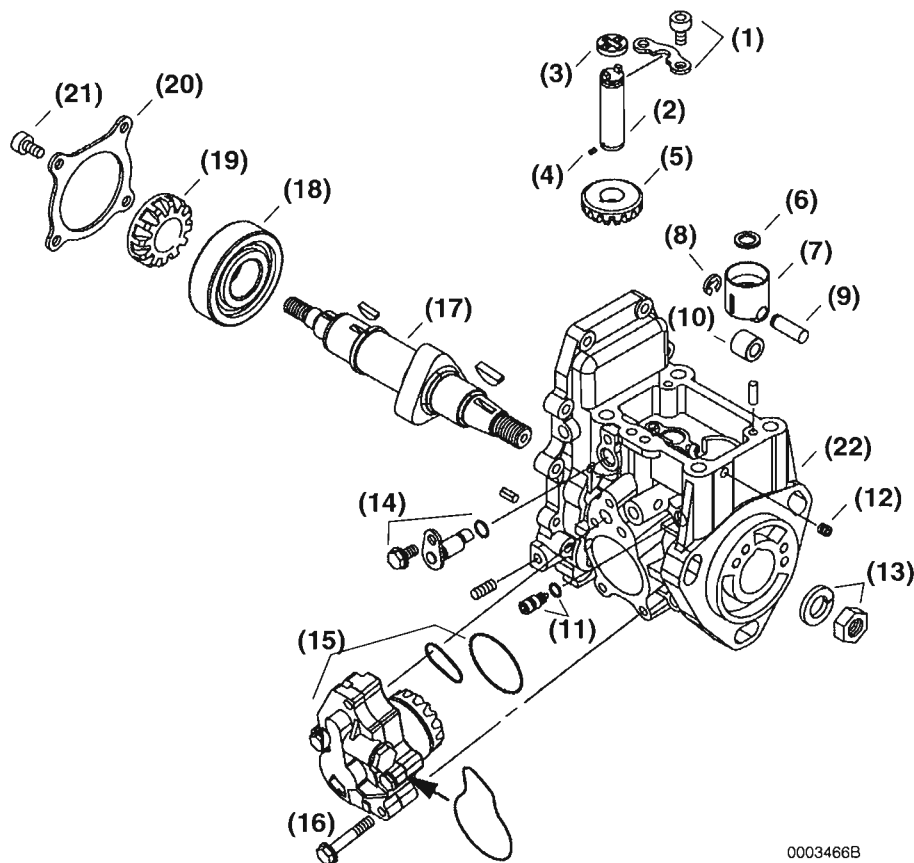

0003466B

- |  |   |                                     |
|--|---|-------------------------------------|
| 1. Distribution Shaft Retainer and Screw | 9. Roller Lifter Pivot Pin                  | 15. Fuel Charge Pump Assembly       |
| 2. Distribution Shaft                    | 10. Roller                                  | 16. Fuel Charge Pump Mount Screw    |
| 3. Distribution Shaft Coupler            | 11. Roller Lifter Alignment Pin             |                                     |
| 4. Distribution Gear Key                 | 12. Control Rack Plug                       |                                     |
| 5. Distribution Gear                     | 13. Camshaft Drive Retaining Nut and Washer |                                     |
| 6. Plunger Shim                          | 14. Governor Link Retaining Shaft and Screw |                                     |
| 7. Roller Lifter Sleeve                  |   |                                     |
| 8. Roller Lifter Retaining Clip          |   |                                     |
|  |   | 17. Camshaft                        |
|  |   | 18. Camshaft Bearing                |
|  |   | 19. Camshaft Gear                   |
|  |   | 20. Camshaft Bearing Retainer       |
|  |   | 21. Camshaft Bearing Retainer Screw |

**Figure 5-3**

## FUEL FLOW

The electric fuel delivery pump (**Figure 5-4, (3)**) feeds fuel oil from the fuel tank (**Figure 5-4, (1)**) to the charge pump (**Figure 5-4, (8)**). A water separator (**Figure 5-4, (2)**) is used to separate water out of the fuel before the electric pump. A fuel filter (**Figure 5-4, (4)**) is used to remove sediment and debris before fuel reaches the charge pump.

The gear driven charge pump then delivers fuel to the injection pump hydraulic head assembly (**Figure 5-4, (30)**). The charge pump boosts the low pressure fuel delivered from the electric pump to a higher, regulated pressure.

Fuel is directed from the charge pump to the plunger and barrel assembly (**Figure 5-4, (13)**) where the high output pressurized fuel is directed to the distribution shaft (**Figure 5-4, (20)**), delivery valves (**Figure 5-4, (21)**), and then through the high pressure fuel injection pipes (**Figure 5-4, (23)**) and fuel injection nozzles (**Figure 5-4, (24)**) into the engine cylinders.

Fuel delivery to each engine cylinder is controlled by camshaft rotation. As the camshaft rotates, the camshaft lobes push the roller lifter (**Figure 5-4, (12)**) and plunger up to pressurize fuel in the plunger and barrel assembly, which is then directed to the rotating distribution shaft. As the distribution shaft rotates, small ports line up and allow fuel flow to each delivery valve at the precise time needed by each cylinder for proper combustion.

One revolution of the fuel injection pump camshaft completes the injection process for all engine cylinders.

# FUEL INJECTION PUMP

## Fuel Flow Diagram

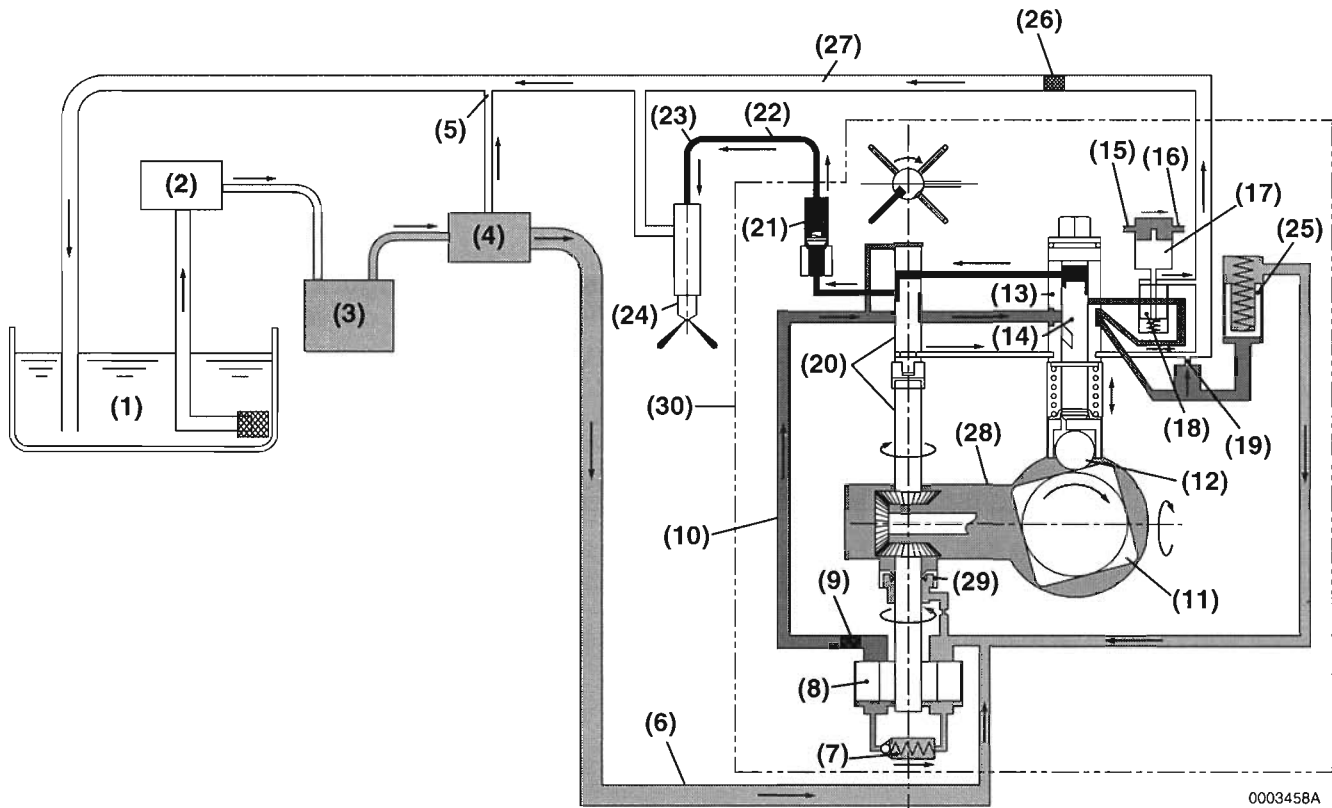

0003458A

- |                                     |                                 |                                       |
|-------------------------------------|---------------------------------|---------------------------------------|
| 1. Fuel Tank                        | 11. Camshaft Lobe               | 22. High Pressure Fuel                |
| 2. Water Separator                  | 12. Roller Lifter               | 23. High Pressure Fuel Injection Pipe |
| 3. Electric Fuel Delivery Pump      | 13. Barrel                      | 24. Fuel Injection Nozzle             |
| 4. Fuel Filter                      | 14. Plunger                     | 25. Accumulator Assembly              |
| 5. Air Bleed Orifice                | 15. Engine Coolant IN           | 26. Return Fuel Strainer              |
| 6. Low Pressure Fuel                | 16. Engine Coolant OUT          | 27. Return Fuel                       |
| 7. Pressure Control Valve           | 17. Thermo-element              | 28. Engine Oil                        |
| 8. Charge Pump                      | 18. Timer Piston                | 29. Oil Seal                          |
| 9. Charge Pump Outlet Fuel Strainer | 19. Return Fuel Orifice         | 30. Fuel Injection Pump Assembly      |
| 10. Regulated Fuel Pressure         | 20. Distribution Shaft Assembly |                                       |
|                                     | 21. Fuel Delivery Valve         |                                       |

**Figure 5-4**

## CHARGE PUMP

The mechanically-operated charge pump (Figure 5-5, (1)) is installed on the side of the fuel injection pump body and is driven by the fuel camshaft gear.

The charge pump delivers regulated high pressure fuel to the injection pump, however it does not function as a transfer pump and requires an electric fuel delivery pump.

The service life of the charge pump is shortened if operated with poor supply pressure and volume.

Yanmar recommends that the charge pump assembly be replaced after 10,000 hours of operation.

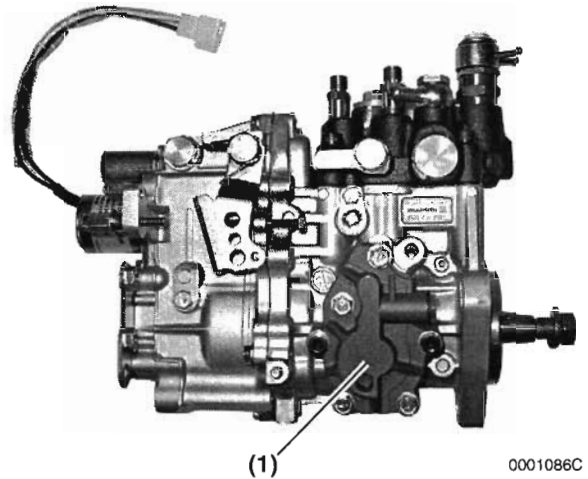

Figure 5-5

## Specifications

	YPD-MP2 / YDP-MP4
Standard Delivery Pressure	58 - 73 psi (0.4-0.5 MPa)
Standard Delivery Volume	0.018 ft <sup>3</sup> /min (500 cm <sup>3</sup> /min)

Pressure and delivery volume calculated under the following conditions:

- Outlet orifice diameter :  $\phi$  0.003 in (0.7 mm)
- Fuel Oil grade : ISO 8217
- Revolutions : 1000 rpm (min<sup>-1</sup>)
- Fuel Oil temp. : 104°F (40°C)

# FUEL INJECTION PUMP

## TIMER CONTROL MECHANISMS

The fuel injection pump has a unified timer control mechanism for engine speed and load and a separate timer control mechanism for cold starting.

The engine is used in a wide range of temperatures, speeds and loads. To provide efficient engine operation under these variables it is necessary to adjust the fuel injection timing according to the engine speed and load. These adjustments maintain optimum firing timing, reduce noise and exhaust gas emissions and provide sufficient fuel for cold starting.

### Speed Timer Function

The engine speed timer is a mechanical timer which uses fluid leakage from a small diameter sub-port (**Figure 5-6, (2)**) in the barrel assembly.

When the engine speed (**Figure 5-7, (1)**) is high, pressure rises before oil can leak from the small diameter port and injection is started.

When the engine speed (**Figure 5-7, (1)**) is low, pressure does not rise until the port is blocked by the plunger (**Figure 5-6, (5)**), the injection start is delayed and additional fuel bleeds off. This delay in injection timing (**Figure 5-7, (2)**) and reduction in fuel quantity helps control noise and emissions.

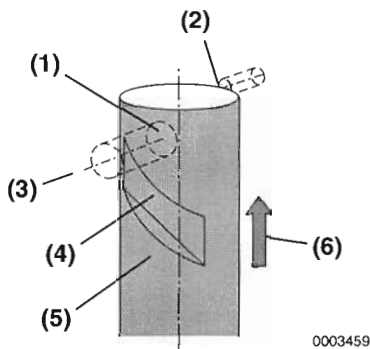

1. Main Port for Suction and Spill
2. Sub Port for Timing Control
3. Fuel Inlet
4. Main Lead
5. Plunger

**Figure 5-6**

### Plunger Position at Start of Fuel Compression

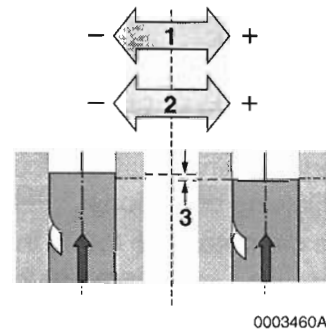

1. Engine speed
2. Injection timing
3. Sub - Port

**Figure 5-7**

## Load Timer Function

The smaller the injection amount, the earlier the load timer causes the main port (**Figure 5-8, (1)**) to close due to the position of the plunger's (**Figure 5-8, (5)**) upper lead (**Figure 5-8, (2)**), resulting in advanced injection timing. This feature is instrumental in preventing the emission of bluish white smoke during low load operation.

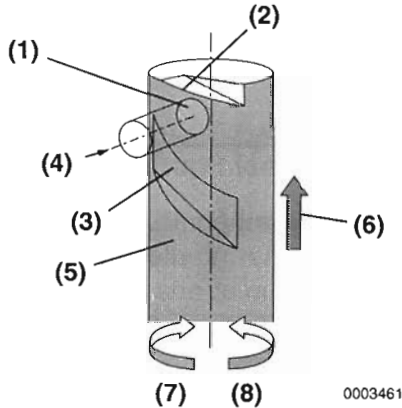

1. Main Port for Suction and Spill
2. Upper Lead
3. Main Lead
4. Fuel Inlet
5. Plunger
6. Plunger Direction "UP"
7. More Fuel
8. Less Fuel

**Figure 5-8**

## Plunger Position When Upper Lead Blocks Main Port

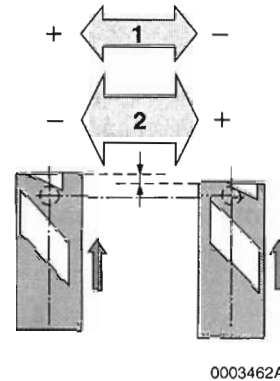

1. Engine load
2. Main Port Blocked (- Later) (+ Earlier)

**Figure 5-9**



# FUEL INJECTION PUMP

## Cold Start Timer

To facilitate easy engine starting under cold temperatures, the timer senses the engine coolant temperature for advancing the fuel injection timing. The cold start timer closes the sub port (**Figure 5-10, (6)**) in cold temperatures which advances the injection timing to assist cold engine starts.

The timer uses a thermo-element (**Figure 5-10, (2)**) that reacts to engine coolant water (**Figure 5-10, (1)**), which circulates around it. Below the set temperature, the return spring holds the timer piston (**Figure 5-10, (3)**) in the closed position. As engine temperature increases, the thermo-element pushes the timer piston to the open position allowing the sub port (**Figure 5-10, (9)**) to function.

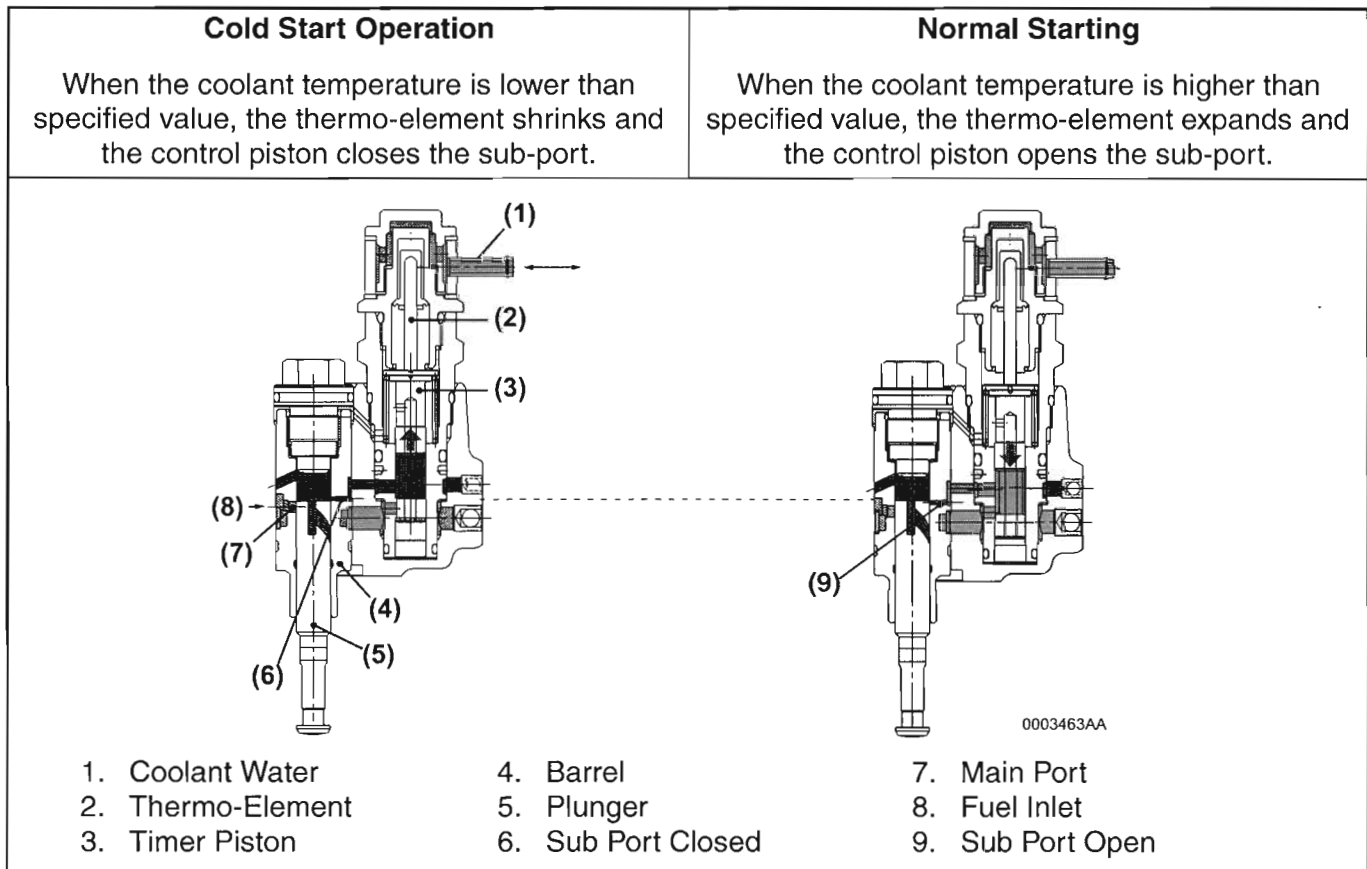

**Figure 5-10**



## FUEL PUMP DISASSEMBLY

Note: Keep all parts clean and in order during disassembly and reinstall all fasteners and small parts to their mating part as components are removed. This will simplify in identification and assembly.

Inspect all parts for wear or damage, replace parts as necessary.

Drain the fuel pump of fuel oil and wash dirt and grease from the outside of the pump before disassembly.

### Governor

1. Mount the fuel pump and governor assembly to a repair stand (**Figure 5-11**).

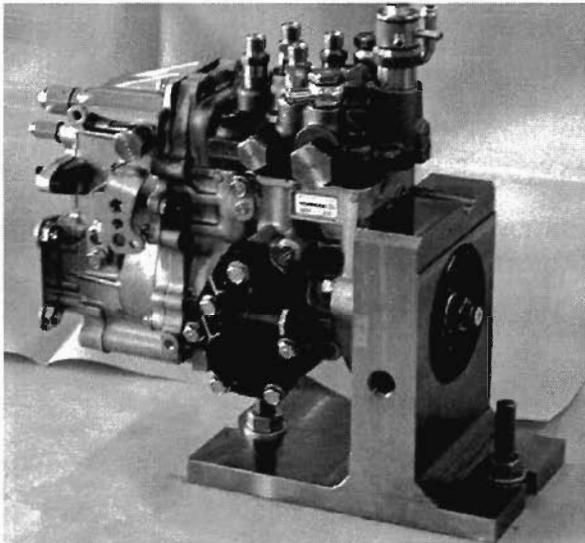

0001170

**Figure 5-11**

2. Remove the governor link retainer shaft bolt (**Figure 5-12, (1)**).

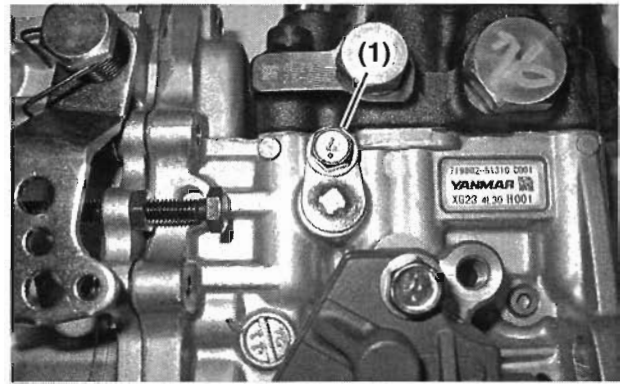

0001171a

**Figure 5-12**

3. Turn the governor link retainer shaft (**Figure 5-13**) counterclockwise 180 degrees to the 6 o'clock position to disengage the governor link (**Figure 5-14**) from the control rack.

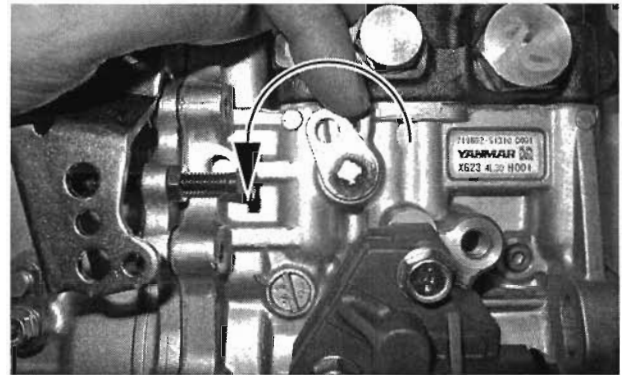

0001172

**Figure 5-13**

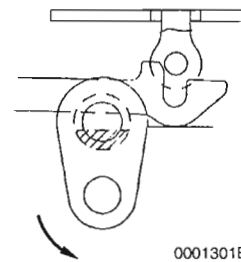

0001301B

**Figure 5-14**

## FUEL INJECTION PUMP

4. Remove the bolts from the governor housing (**Figure 5-15, (2)**) and remove it from the fuel pump body (**Figure 5-15, (1)**).



0001174a

**Figure 5-15**

5. Attach a stop to the camshaft and remove the governor sleeve and weight assembly retaining nut (**Figure 5-16, (1)**).

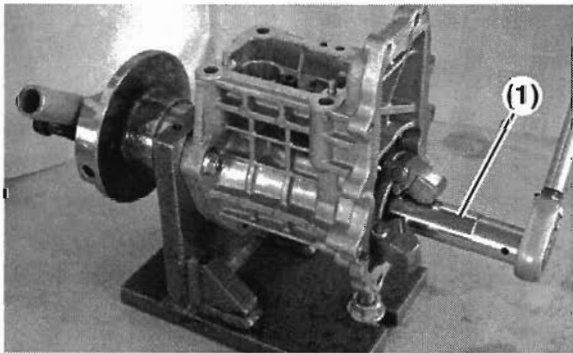

0001251

**Figure 5-16**

## Charge Pump

1. Remove the charge pump mounting screws (**Figure 5-17, (2)**) and charge pump (**Figure 5-17, (1)**).

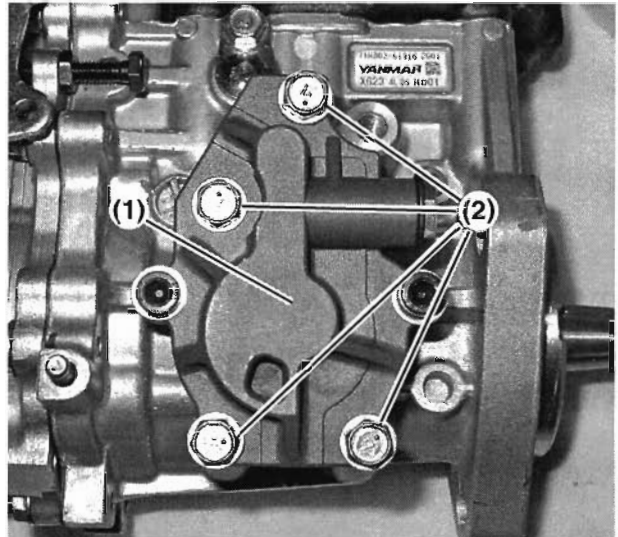

0001197a

**Figure 5-17**

2. Remove and discard the two housing O-rings (**Figure 5-18, (1)**).

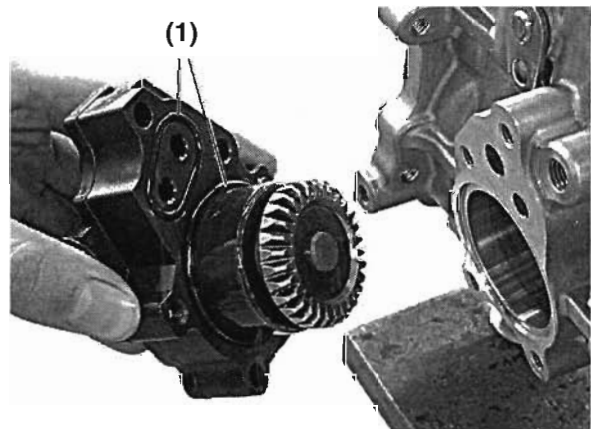

0001198

**Figure 5-18**

3. Remove the two cover retainer bolts (**Figure 5-19, (4)**) and discard O-ring (**Figure 5-19, (3)**).

4. Inspect the pump housing (**Figure 5-19, (1, 2)**). If the pump housing is worn, replace the complete pump assembly.

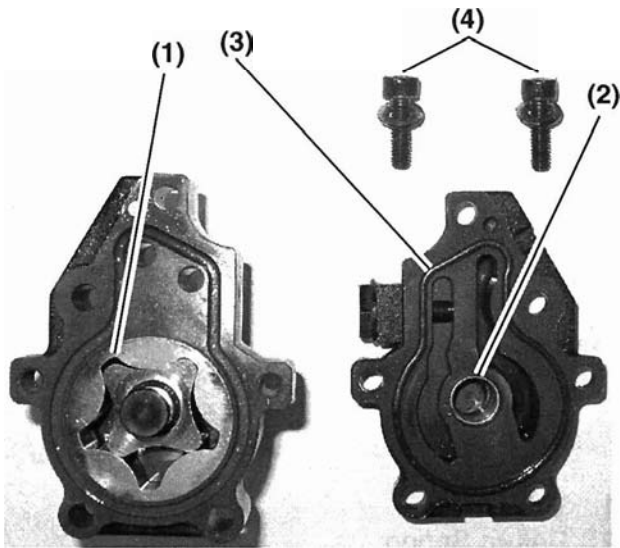

0003559

**Figure 5-19**

5. Inspect the drive gear (**Figure 5-20, (1)**), rotor assembly (**Figure 5-20, (2)**), drive pin (**Figure 5-20, (3)**), seal (**Figure 5-21, (2)**) oil ports (**Figure 5-21, (3)**) and O-ring seal areas (**Figure 5-21, (1)**) for wear. If damaged or worn, replace the complete pump assembly.



0003561

**Figure 5-20**

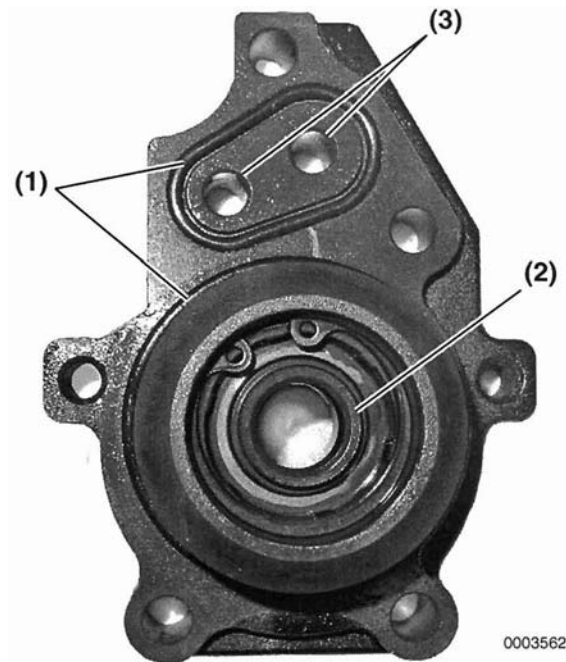

0003562

**Figure 5-21**



# FUEL INJECTION PUMP

## Hydraulic Head

1. Mark the positions of the fuel inlet (Figure 5-22, (1)) and return fittings (Figure 5-22, (2)) and remove.

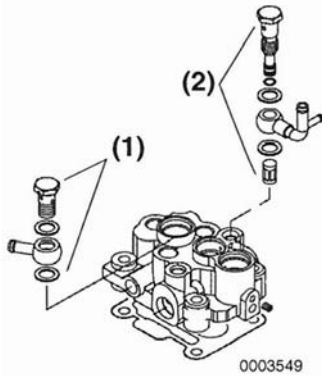

Figure 5-22

### IMPORTANT

The delivery valve has many parts that are very small. Do not drop or lose the check valve.

2. Remove each of the delivery valve housings valves and gaskets (Figure 5-23).

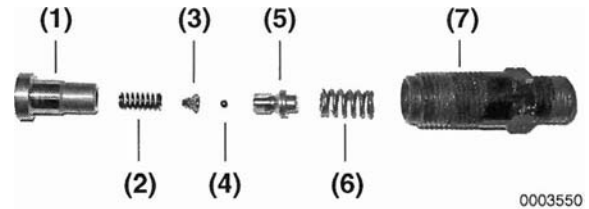

Figure 5-23

Note: Be careful not to lose the secondary check balls during disassembly of the delivery valves.

3. Disassemble each delivery valve (Figure 5-24).

Note: Keep and identify all parts in order during disassembly. Do not mix valve parts. If reused, each valve must be reassembled with the original parts and reinstalled in the original port.



1. Valve Seat
2. Return Spring
3. Secondary Check Ball Spring Seat
4. Secondary Check Ball
5. Delivery Valve
6. Primary Spring
7. Delivery Valve Housing

Figure 5-24

4. Remove the distribution shaft plug (Figure 5-25, (1)), and O-ring (Figure 5-25, (2)).

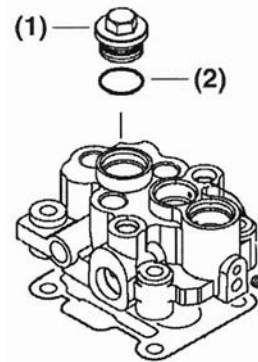
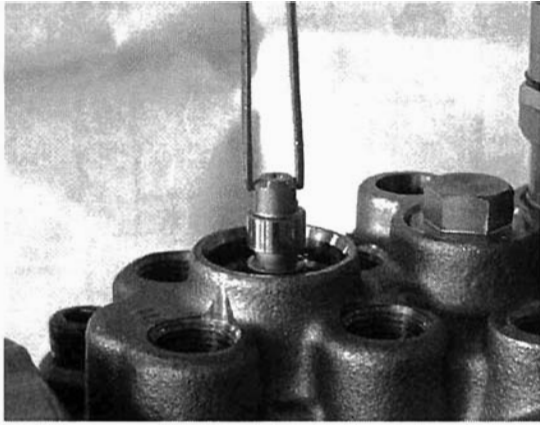

Figure 5-25

## IMPORTANT

*Do not use magnetized tools, as this may cause fuel pump components to become magnetized and attract metal debris.*

- Remove the distribution shaft (Figure 5-26).



0001185

**Figure 5-26**

Note: Store parts in clean oil to prevent oxidation.

- Remove the plunger and barrel plug (Figure 5-27, (1)), O-ring (Figure 5-27, (2)) and copper seal (Figure 5-27, (3)).

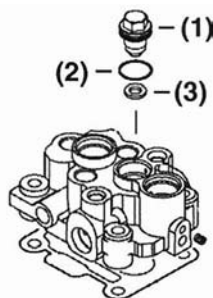

**Figure 5-27**

- Note the position of the coolant fitting (Figure 5-28, (3)) and remove the coolant plug (Figure 5-28, (1)), gasket (Figure 5-28, (2)) and fitting. Remove the thermo-element assembly (Figure 5-28, (4)), which includes the timer piston (Figure 5-28, (5)), timer piston return spring (Figure 5-28, (6)) timer housing (Figure 5-28, (7)), gaskets (Figure 5-28, (8)) and seal (Figure 5-28, (9)).

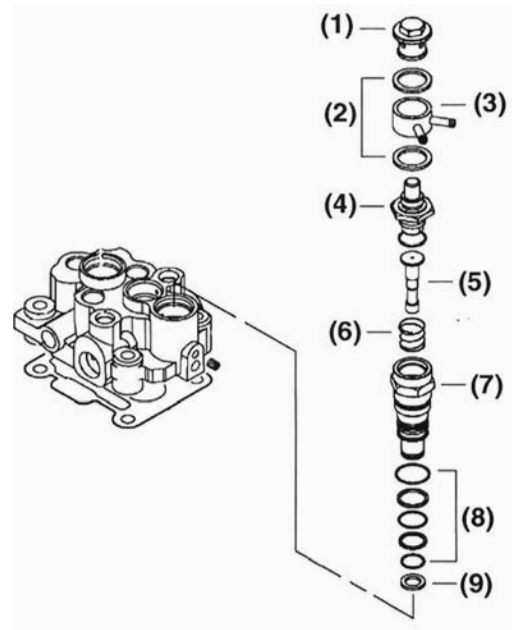

0003551

**Figure 5-28**

## FUEL INJECTION PUMP

8. Remove the charge pump fuel outlet strainer plug (**Figure 5-29, (1)**) and gasket (**Figure 5-29, (2)**). Do not remove the strainer. Remove the accumulator plug (**Figure 5-29, (3)**) washer (**Figure 5-29, (4)**), spring and piston (**Figure 5-29, (5,6)**).

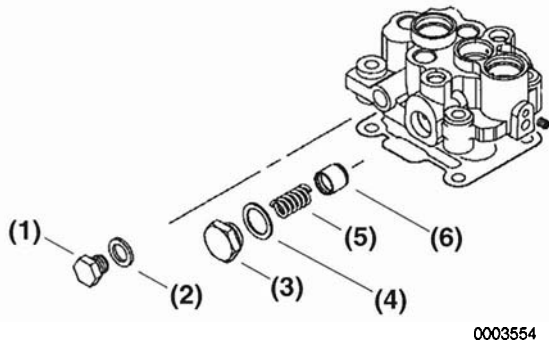

**Figure 5-29**

9. Remove the four hydraulic head bolts (**Figure 5-30, (1)**).

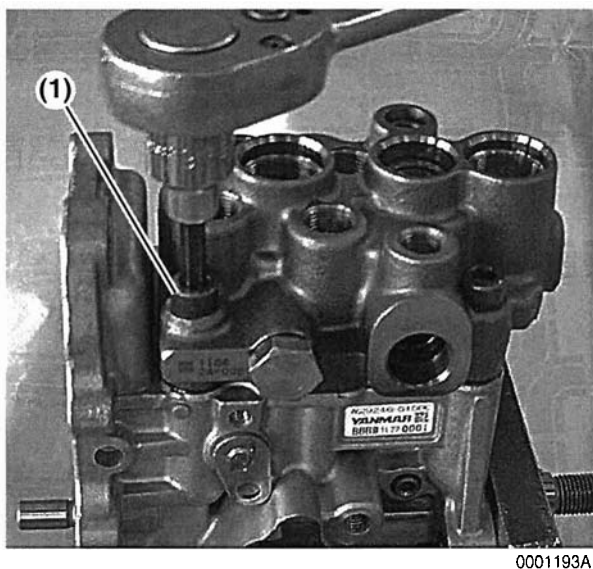

**Figure 5-30**

10. Remove the hydraulic head assembly and gasket (**Figure 5-31, (1)**).

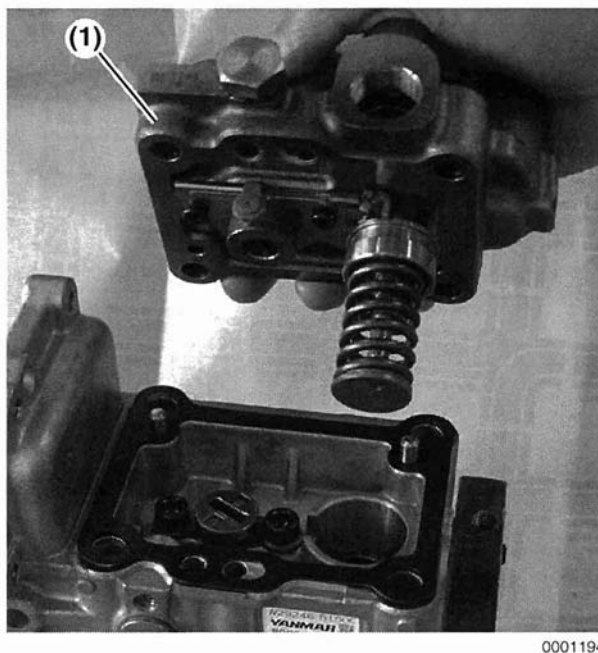

**Figure 5-31**

11. Use the spring compressor tool (**Figure 5-33, (2)**) (Included in Yanmar Special Tool Kit P/N 458091) to compress the plunger spring (**Figure 5-32, (1)**) and remove the spring retainer (**Figure 5-33, (1)**).

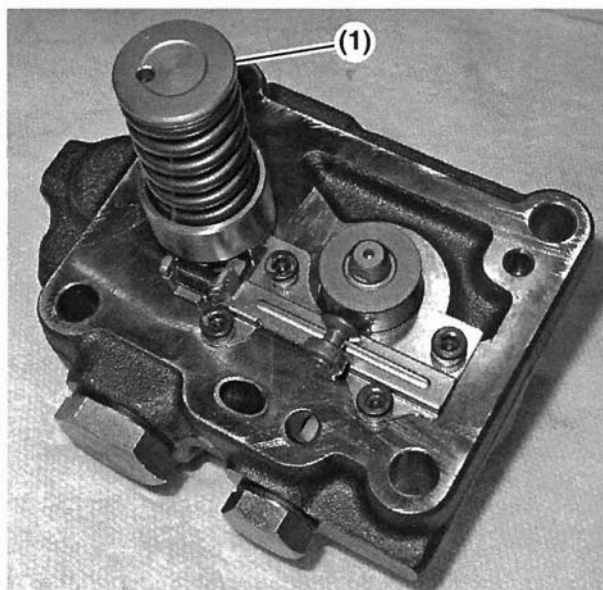

**Figure 5-32**



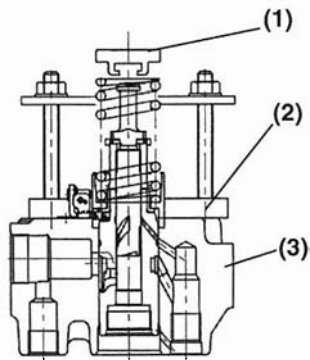

1. Spring Retainer
2. Spring Compressor Tool
3. Hydraulic Head

**Figure 5-33**

12. Remove the control rack return spring (**Figure 5-34, (1)**).

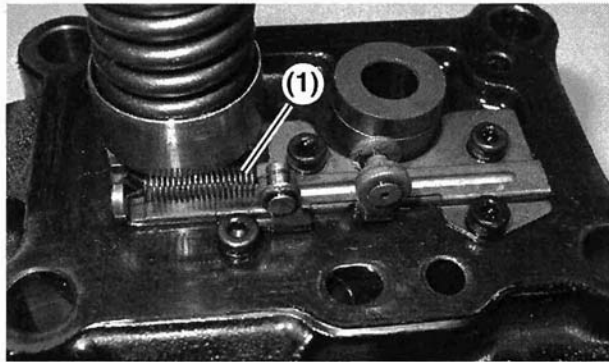

0001214a

**Figure 5-34**

13. Remove the control rack guide and bolts (**Figure 5-35, (1)**).

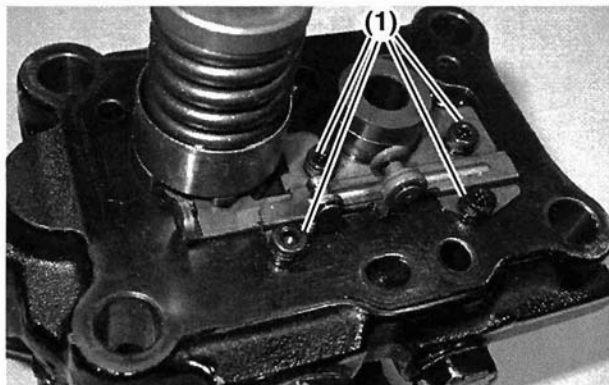

00001215a

**Figure 5-35**

14. Remove the spring retainer (**Figure 5-36, (1)**), control sleeve (**Figure 5-36, (2)**) and plunger (**Figure 5-36, (3)**).

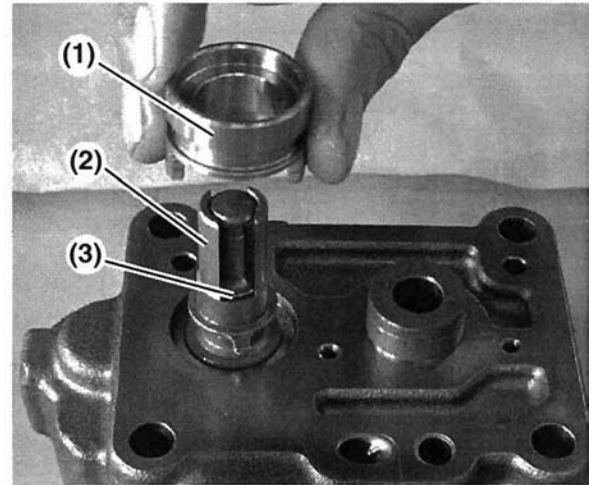

00001217

**Figure 5-36**

Note: Store all valves (**Figure 5-37**) removed from hydraulic head assembly in clean oil to prevent oxidation.

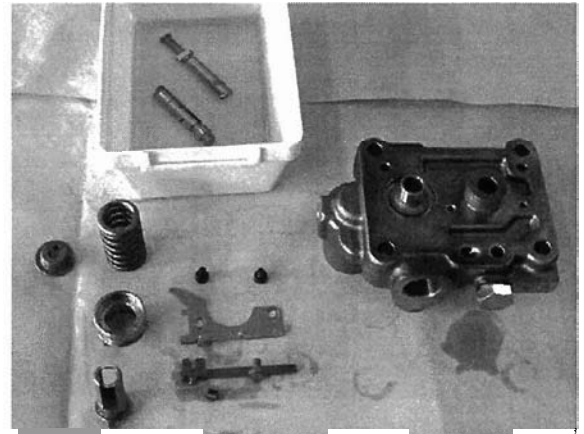

0001220

**Figure 5-37**

# FUEL INJECTION PUMP

## Distribution Shaft, Camshaft and Roller Lifter Removal

1. Remove the distribution shaft coupler (Figure 5-38, (1)).

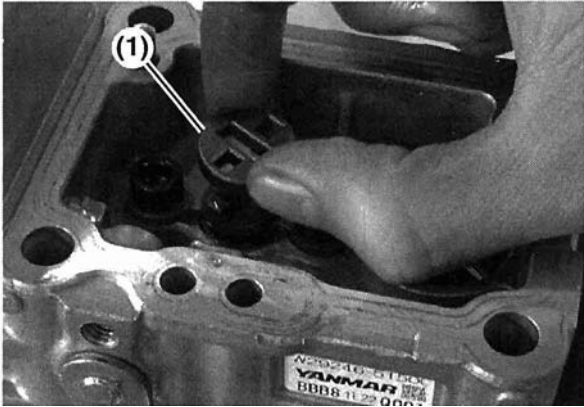

Figure 5-38

2. Remove the distribution shaft retainer bolts (Figure 5-39, (1)) and retainer (Figure 5-39, (2)).

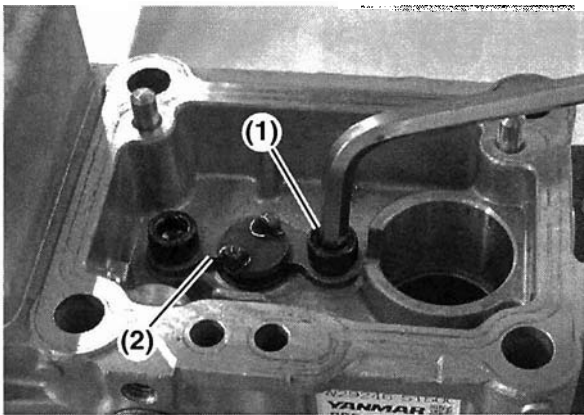

Figure 5-39

3. Remove the roller lifter alignment pin (Figure 5-40, (1)) and O-ring and the link lifter (Figure 5-40, (2)) and O-ring.

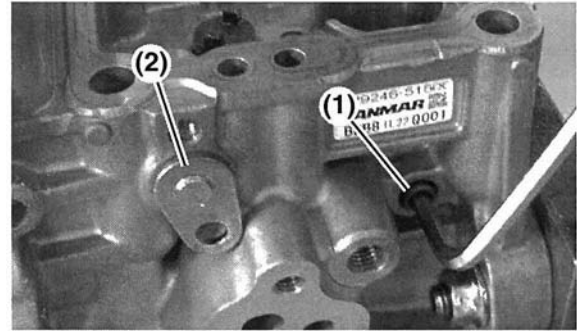

Figure 5-40

4. Remove the roller lifter (Figure 5-41, (2)). Retain the shim (Figure 5-41, (1)) located in the lifter bore.

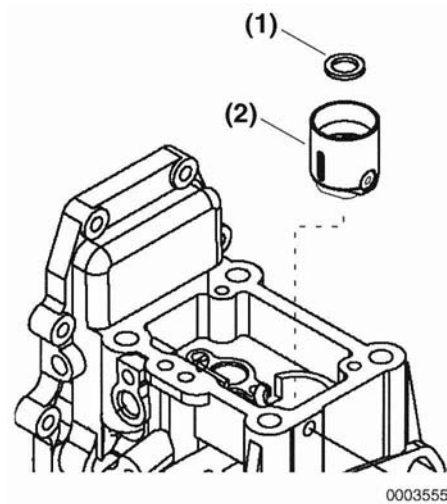
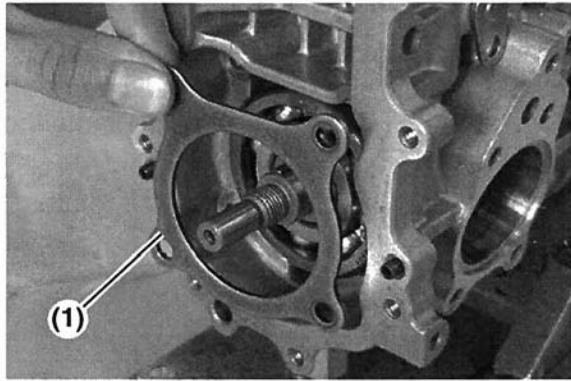

Figure 5-41



- Remove the camshaft bearing retainer bolts and retainer (**Figure 5-42, (1)**).



0001205

**Figure 5-42**

- (**MP2 - 3 Cylinder Model Pumps**) Align the camshaft keyway (**Figure 5-43, (1)**) with the appropriate timing mark on the body 3 Cylinder Model (**Figure 5-43, (2)**) or 4 Cylinder Model (**Figure 5-43, (3)**).

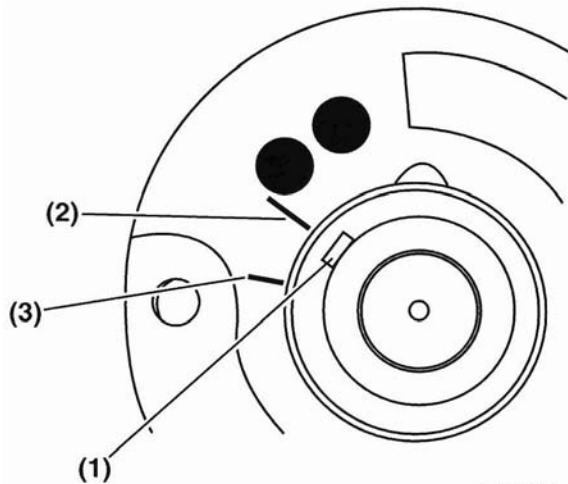

0001207J

**Figure 5-43**

- (**MP4 Model Pump**) Align the camshaft keyway (**Figure 5-44, (2)**) with the embossed mark (**Figure 5-44, (1)**) on the body.

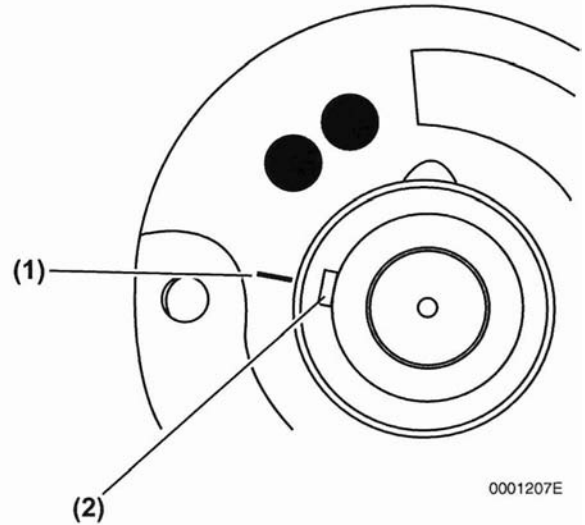

0001207E

**Figure 5-44**

- Lift the distribution shaft (**Figure 5-45, (1)**) slightly and pull out the camshaft (**Figure 5-45, (2)**) being careful to avoid damaging the camshaft lobes.

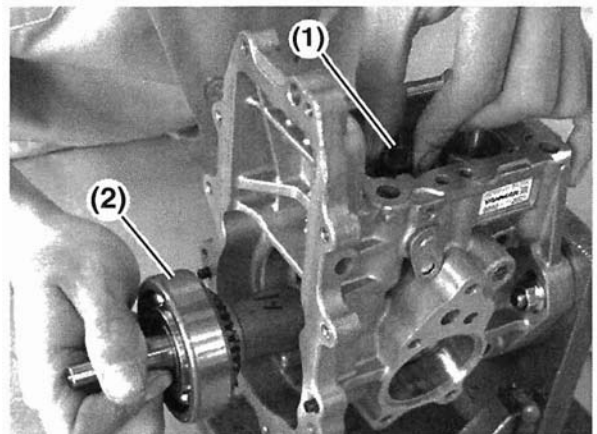

0001208

**Figure 5-45**

## FUEL INJECTION PUMP

9. Remove the distribution shaft assembly (Figure 5-46).

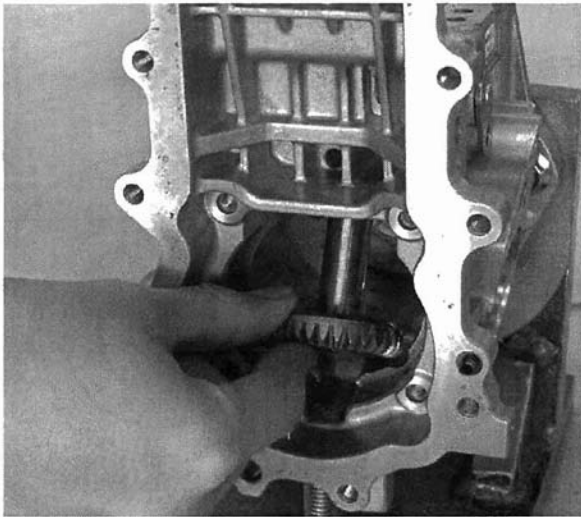

0001210

**Figure 5-46**

## FUEL PUMP REASSEMBLY

### Distribution Shaft and Camshaft

1. Invert the pump body and apply assembly grease to the distribution shaft and gears (Figure 5-47, (1)) before installing it into the pump body.

Note: Check that the distribution shaft rotates freely after installation.

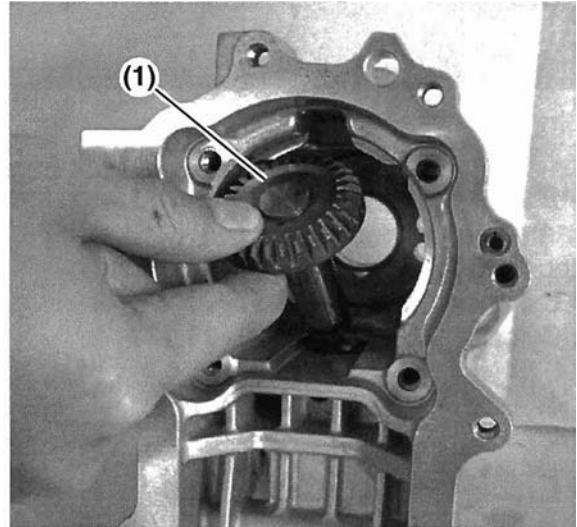

0001237

**Figure 5-47**

2. Apply assembly grease to the camshaft lobes, bushing journal and ball bearing.

3. With the distribution shaft gear touching the pump body, insert the camshaft into the body. During installation prevent the cam lobes from hitting the distribution shaft gear and the camshaft key from hitting the camshaft bushing. **(Figure 5-48).**

Note: 4-cylinder camshafts require special care during reassembly due to tight tolerances.

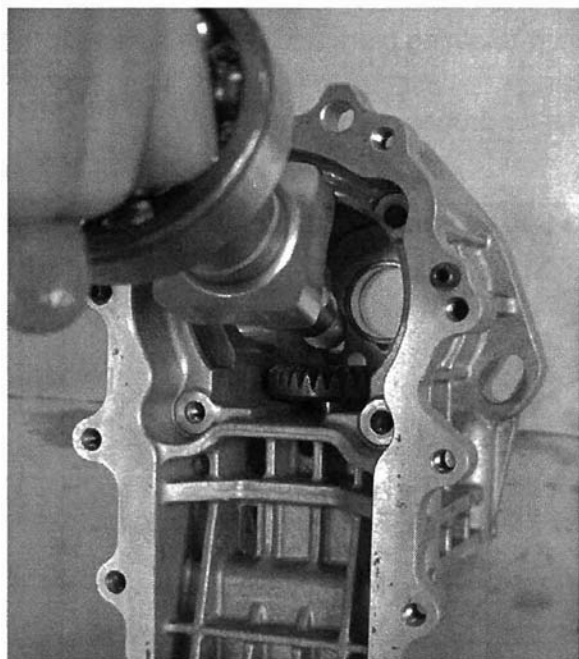

0001239

**Figure 5-48**

4. Install the camshaft bearing retainer and bolts **(Figure 5-49, (1))** and tighten to 6 - 7 ft-lb. (8 - 10 N·m).

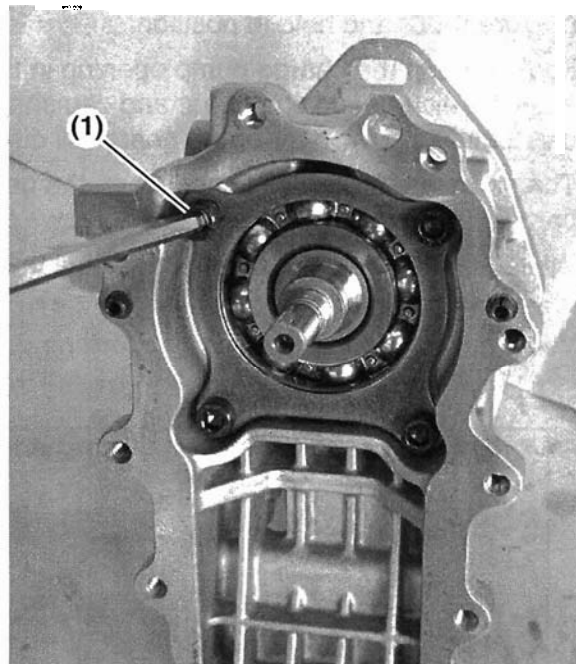

0001241

**Figure 5-49**

# FUEL INJECTION PUMP

## Gear Alignment

Note: Verify model of fuel injection pump before proceeding

1. Rotate the camshaft to the correct angle (aligning keyway to marks) for the model pump being serviced (**Figure 5-50**) and hold in position.
2. Look through the charge pump opening in the case and slightly lift the distribution shaft and rotate to align the distribution shaft gear and camshaft gears marks. Once the marks are aligned, do not raise the distribution shaft too far or the gears will disengage and misalign.
3. The gears are properly aligned when the gear marks are aligned, the distribution shaft drive lugs are in parallel alignment with the retainer screws and the camshaft keyway is at proper angle from step 1.
4. While holding the gear alignment, install the distribution shaft retaining plate and tighten screws to 6 - 7 ft-lb. (8 - 10 N·m).
5. Verify proper gear alignment by checking gear timing marks for proper alignment.

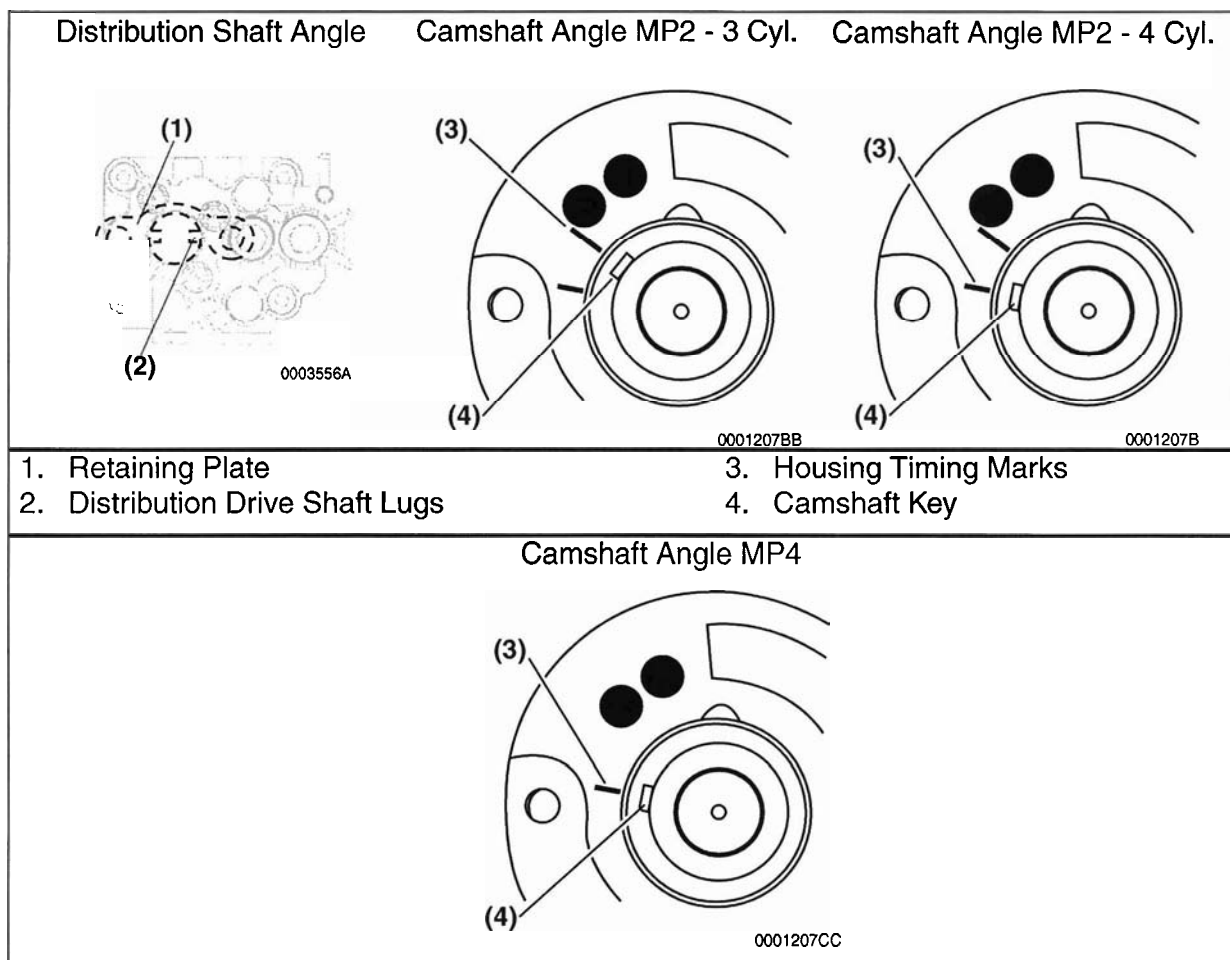
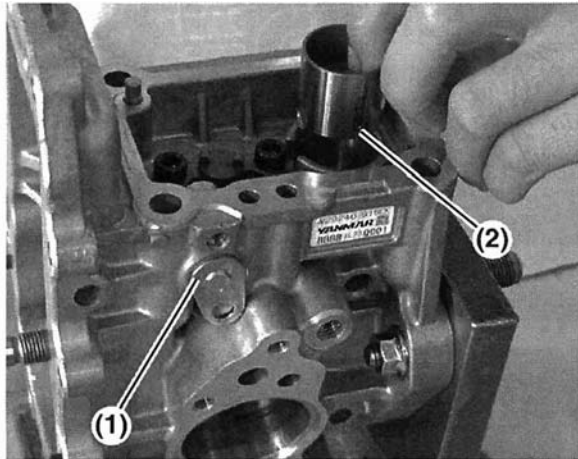

**Figure 5-50**



## Roller Lifter

1. Install the link lifter (**Figure 5-51, (1)**) and O-ring.
2. Install the roller lifter (**Figure 5-51, (2)**) with the groove on the side of the lifter aligned with the lifter alignment pin hole.



0001248A

**Figure 5-51**

3. With roller lifter groove aligned, install the roller lifter alignment pin (**Figure 5-52, (1)**). Slowly tighten the pin by hand (4 mm hex wrench) while turning camshaft to ensure the lifter moves freely with pin in position. Torque the pin to 3 - 4 ft-lb. (4 - 5 N·m). Lifter must move freely after pin is torqued.

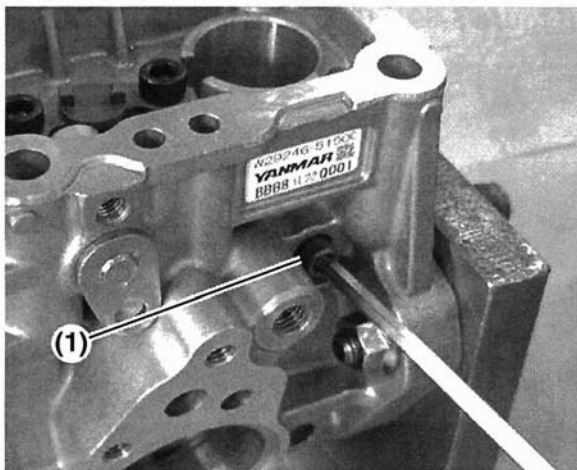

0001249

**Figure 5-52**

## Plunger and Control Rack

1. Install the plunger (**Figure 5-53, (1)**) into the head assembly.

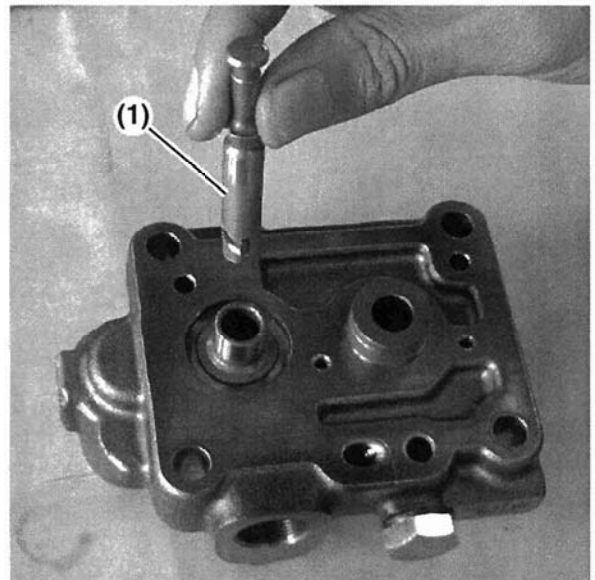

0001230

**Figure 5-53**

2. Install the control sleeve (**Figure 5-55, (2)**) aligning the plunger identification marking (example: "W4") (**Figure 5-54, (4)**) with the ball (**Figure 5-54, (2)**) of the control sleeve.

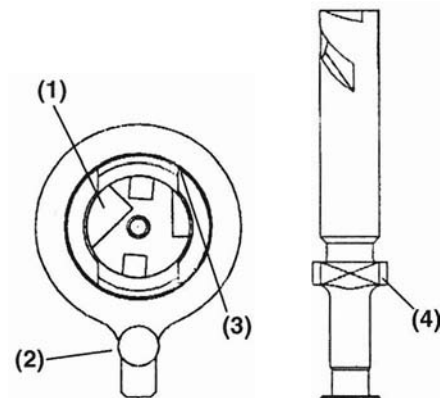

0001231

1. Upper Lead
2. Ball
3. Sub-lead

4. Identification Marking

**Figure 5-54**

## FUEL INJECTION PUMP

3. Install the spring retainer (**Figure 5-55, (1)**).

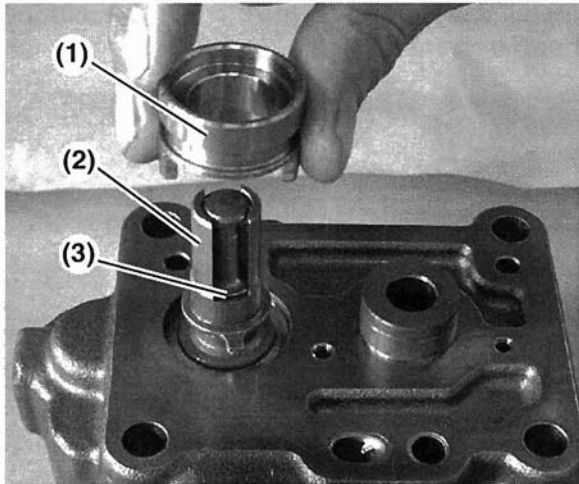

1. Spring Retainer  
2. Control Sleeve  
3. Plunger

00001217

**Figure 5-55**

4. Install the control rack guide (**Figure 5-56, (2)**) into the corresponding positions (hole and pin) on the spring retainer (**Figure 5-56, (1)**). Also see **Figure 5-57** and **Figure 5-58**.

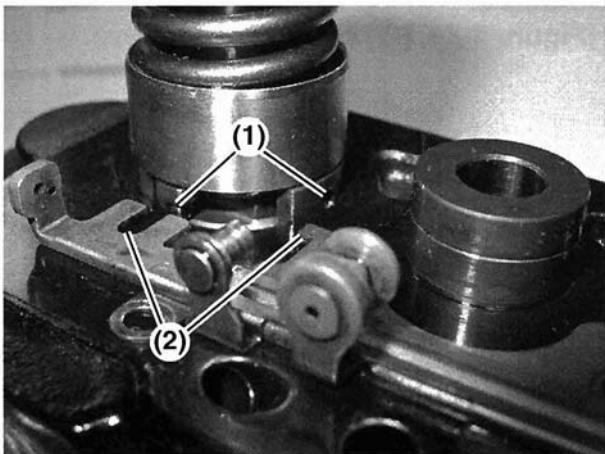

00001233A

**Figure 5-56**

5. Installing the slide into the spring retainer (**Figure 5-57, (1)**), (**Figure 5-58, (1)**).

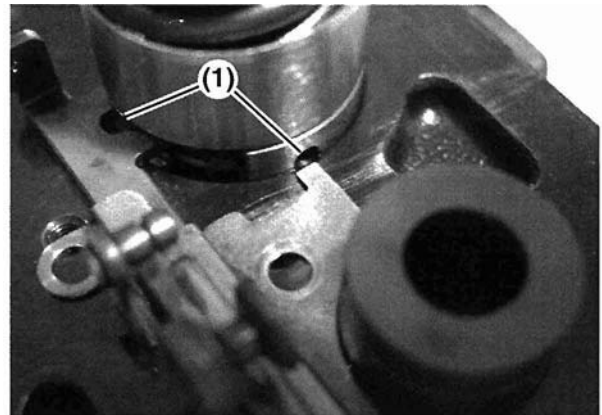

00001233B

**Figure 5-57**

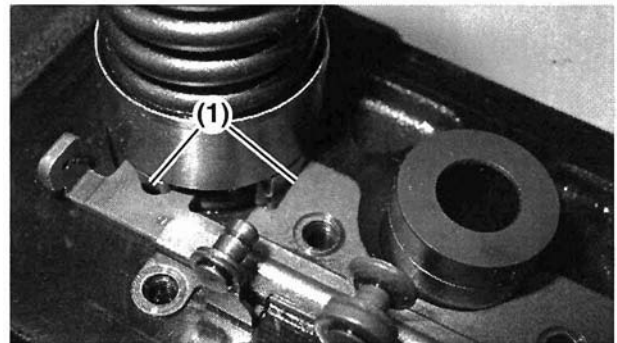

00001233C

**Figure 5-58**

6. Install and tighten the four bolts (**Figure 5-59, (1)**) to 2 - 3 ft-lb. (3 - 4 N-m).

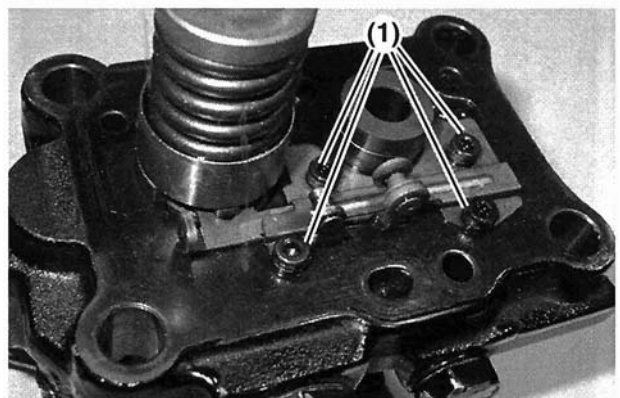

00001215a

**Figure 5-59**

7. Measure the rack (**Figure 5-60, (4)**) movement, the range of rack motion should be approximately 14 mm of total travel.
8. Measure rack backlash, the total backlash should be equal to or less than 0.008 in. (0.2 mm). If the backlash is excessive, replace the rack assembly and control sleeve.

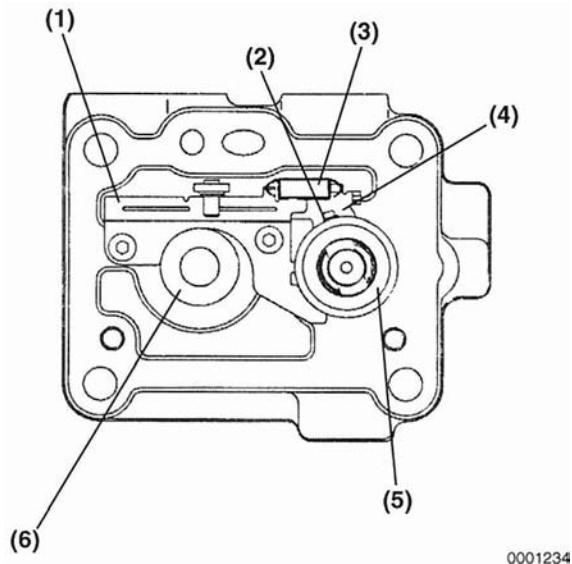

- |                          |                              |
|--------------------------|------------------------------|
| 1. Control Rack Guide    | 4. Rack                      |
| 2. Control Sleeve        | 5. Upper Spring Retainer     |
| 3. Rack Auxiliary Spring | 6. Distribution Shaft Sleeve |

**Figure 5-60**

9. Install the rack return spring (**Figure 5-61, (1)**). The spring must be able to return the rack from the maximum decreased fuel position to the maximum increased fuel position.

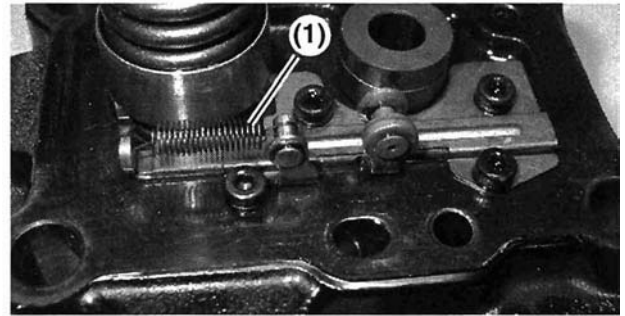

**Figure 5-61**

10. Install the plunger spring (**Figure 5-62, (1)**) and spring retainer (**Figure 5-62, (2)**). Use the spring compressor tool (**Figure 5-63, (2)**) (Included in Yanmar Special Tool Kit P/N 458091) to compress the plunger spring and install the spring retainer.

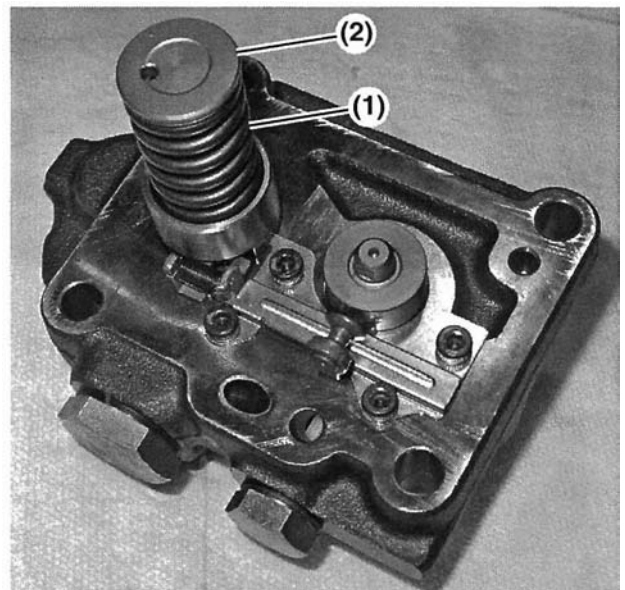

**Figure 5-62**



# FUEL INJECTION PUMP

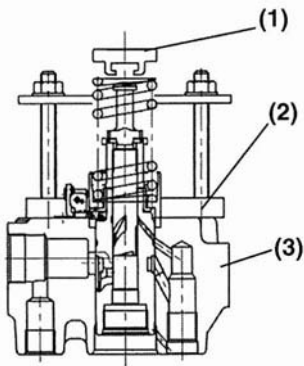

1. Spring Retainer
2. Spring Compressor Tool
3. Hydraulic Head

**Figure 5-63**

11. Install the distribution shaft coupler (**Figure 5-64, (1)**).

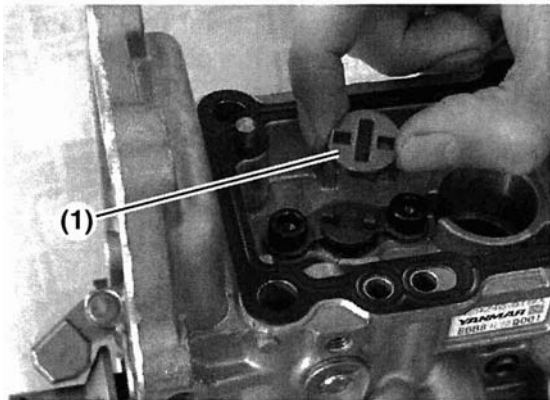

**Figure 5-64**

12. Install a new head gasket (**Figure 5-65, (1)**).



**Figure. 5-65**

13. Install the original plunger shim(s) (**Figure 5-66, (1)**) inside the lifter.

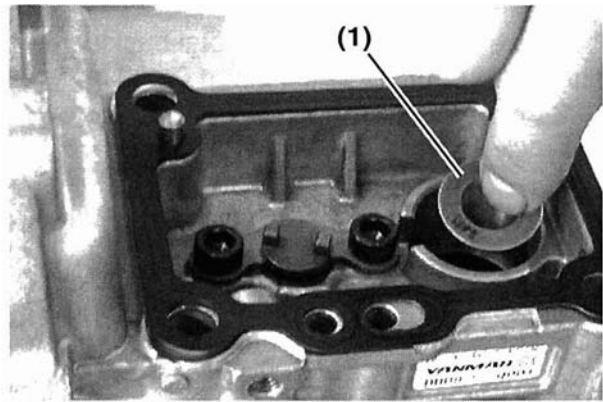

**Figure 5-66**

14. Install the hydraulic head assembly and temporarily tighten the (6 mm hex) head bolts evenly in the order as shown (**Figure 5-67, (1, 2, 3, 4)**) until the surfaces of the head and the pump body contact each other. Then tighten to torque of  
(MP2 - 13 - 16 ft-lb. (18 - 22 N·m))  
(MP4 - 21 - 24 ft-lb. (28 - 32 N·m)) in a diagonal order.

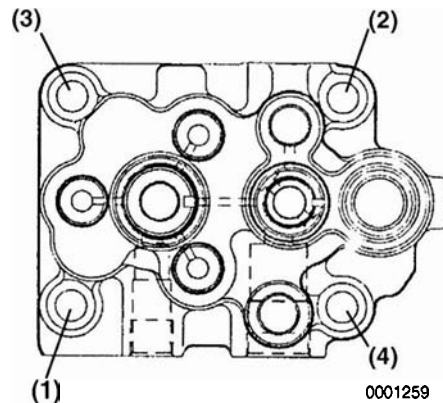

**Figure 5-67**

## Plunger (Bottom Clearance) Measurement

The MP fuel pump injection timing is set by adjusting the plunger height. This is accomplished using shims in the roller lifter body to move the plunger up or down (bottom clearance) from the camshaft base circle.

Note: Do not use the ball tip on the dial indicator when measuring, use the dial indicator extension alone.

1. Mount the dial indicator (from Yanmar Special Tool Kit P/N 458091) in the adapter and thread into barrel.
2. Position the camshaft with the roller lifter at the bottom of the cam profile.
3. Remove the dial indicator and adapter and zero the dial indicator (**Figure 5-68, (1)**) using the specified spacer (**Figure 5-68, (2)**). The correct size spacer can be found in the calibration data sheet (bottom clearance [mm]) for each pump number.

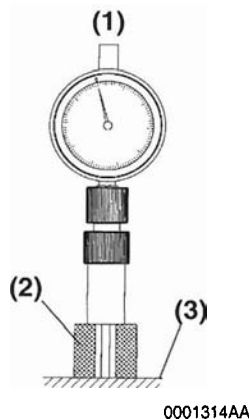

- |                   |                 |
|-------------------|-----------------|
| 1. Dial Indicator | 3. Flat Surface |
| 2. Plunger Spacer |                 |

**Figure 5-68**

5. Using shims from the shim kit in the Yanmar Parts Catalog (MP2 - P/N 158553-51250), (MP4 - P/N 129906-51400), increase or decrease the shim pack (**Figure 5-69, (3)**) in the roller lifter bore to obtain the zero mark ( $\pm 0.03$  mm) on the dial indicator.

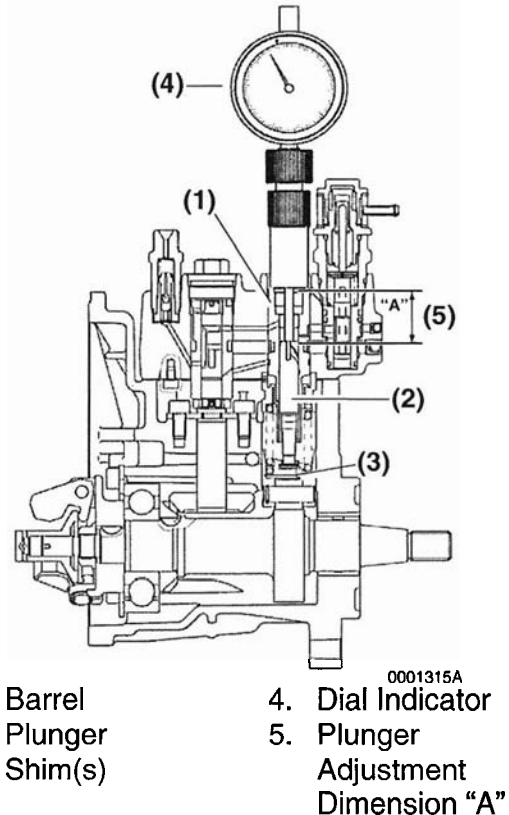

- |            |                                     |
|------------|-------------------------------------|
| 1. Barrel  | 4. Dial Indicator                   |
| 2. Plunger | 5. Plunger Adjustment Dimension "A" |
| 3. Shim(s) |                                     |

**Figure 5-69**

4. Reinstall the dial indicator (**Figure 5-69, (4)**) into the barrel (**Figure 5-69, (1)**) and record the measurement.

# FUEL INJECTION PUMP

## Hydraulic Head and Valve(s) Reassembly

1. Set the camshaft to the correct angle as used during the gear alignment.
2. Lubricate the distribution shaft.
3. Align the drive lugs on the bottom of the distribution shaft and install to engage the distribution shaft coupler.

Note: The flat on the distribution shaft (**Figure 5-70, (1)**) should face toward the engine side of the pump (or away from the accumulator piston side).

4. Install the distribution shaft plug (**Figure 5-70, (3)**) and O-ring (**Figure 5-70, (2)**) and tighten to 11 ft-lb. (15 N·m).

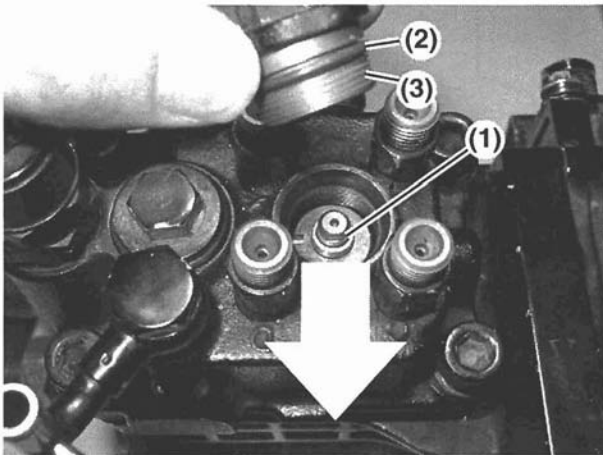

**Figure 5-70**

Note: Some old style hydraulic heads have a distribution shaft plug with a flat bottom. The replacement will require a new plug to allow clearance for the taller distribution shaft. The parts catalog lists the new plug with a machined recess on the bottom.

5. Install new delivery valve seat seal(s) (**Figure 5-71, (1)**).

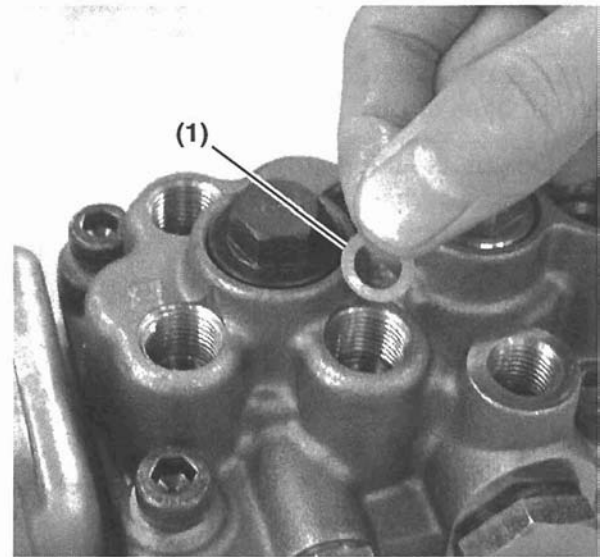

0001274

**Figure 5-71**

6. Assemble and install each delivery valve (**Figure 5-72**). Tighten each delivery valve housing to 30 - 33 ft-lb. (40 - 45 N·m).

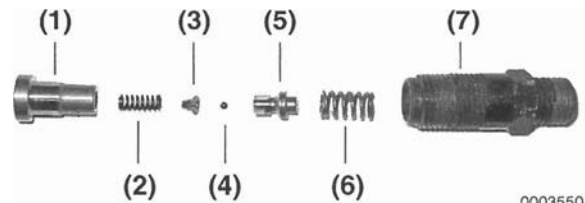

0003550

1. Valve Seat
2. Return Spring
3. Secondary Check Ball Spring Seat
4. Secondary Check Ball
5. Delivery Valve
6. Primary Spring
7. Delivery Valve Housing

**Figure 5-72**

7. Install the charge pump fuel outlet strainer gasket (**Figure 5-73, (2)**) and tighten the plug (**Figure 5-73, (1)**) to 16 - 21 ft-lb. (25 - 29 N·m).

8. Install the accumulator piston (**Figure 5-73, (6)**) and check that it moves freely. Install the spring (**Figure 5-73, (5)**), seal (**Figure 5-73, (4)**) and tighten the plug (**Figure 5-73, (3)**) to 37 - 41ft-lb. (50 - 55 N·m).

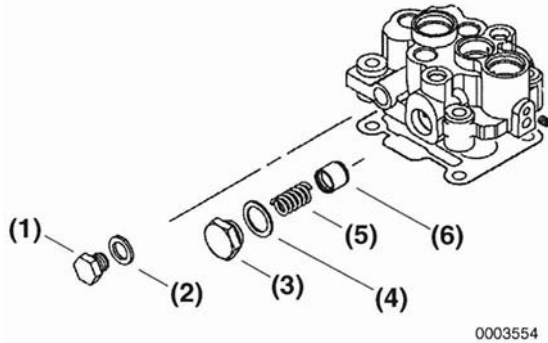

**Figure 5-73**

9. Install a new timer housing seal (**Figure 5-74, (1)**)

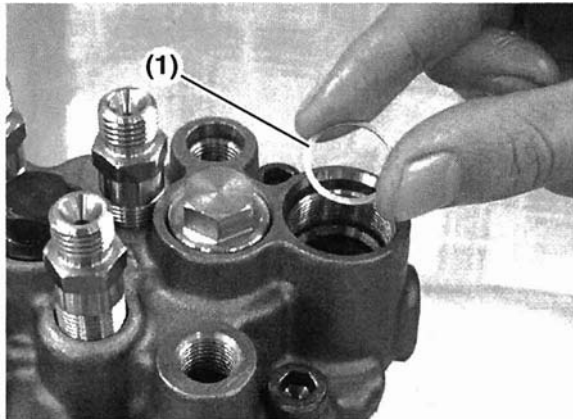

**Figure 5-74**

10. Install a new seal (**Figure 5-75, (9)**) into the head. Install new O-rings (**Figure 5-75, (8)**) on the timer housing (**Figure 5-75, (7)**) and install the timer housing tightening to 30 - 33 ft-lb. (40 - 45 N·m).
11. Install the timer spring (**Figure 5-75, (6)**) and piston (**Figure 5-75, (5)**) into the housing.

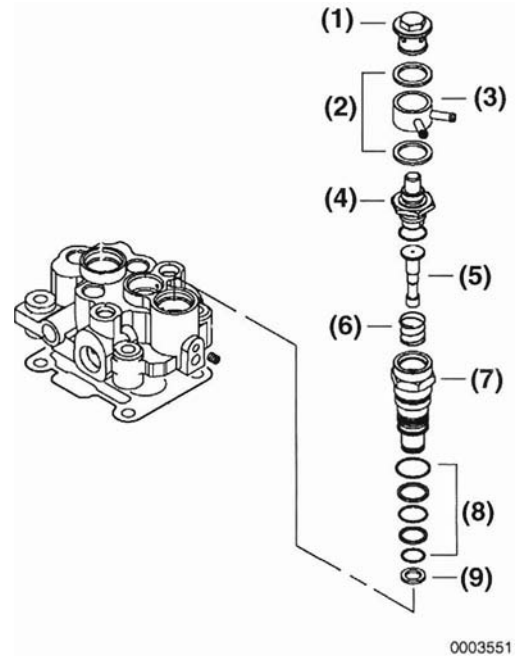

**Figure 5-75**



# FUEL INJECTION PUMP

- 12. Install a new O-ring (**Figure 5-76, (2)**) on the thermo-element (**Figure 5-76, (1)**) and tighten to 22 - 26 ft-lb. (30 - 35 N·m). Do not over-torque.

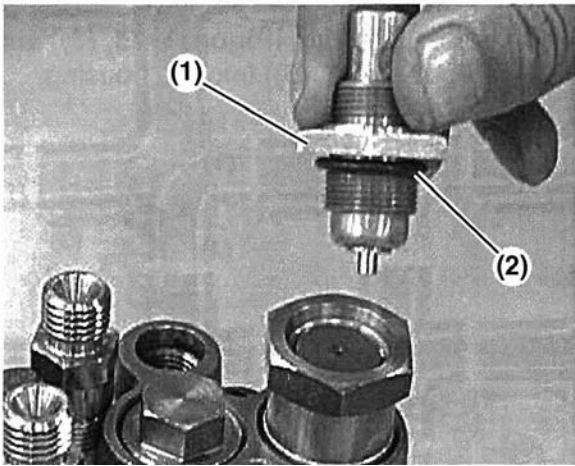

Figure 5-76

- 13. Install the engine coolant fitting (**Figure 5-75, (3)**) and seals in their original position.
- 14. Install the coolant plug (**Figure 5-75, (1)**) and tighten to 16 - 18 ft-lb. (22 - 25 N·m). Do not over-torque.
- 15. Install the fuel return (**Figure 5-77, (2)**) and inlet fittings (**Figure 5-77, (1)**), seals and plugs to positions marked in disassembly.

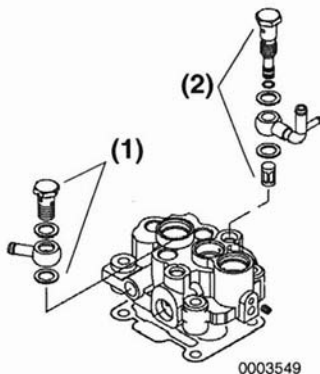
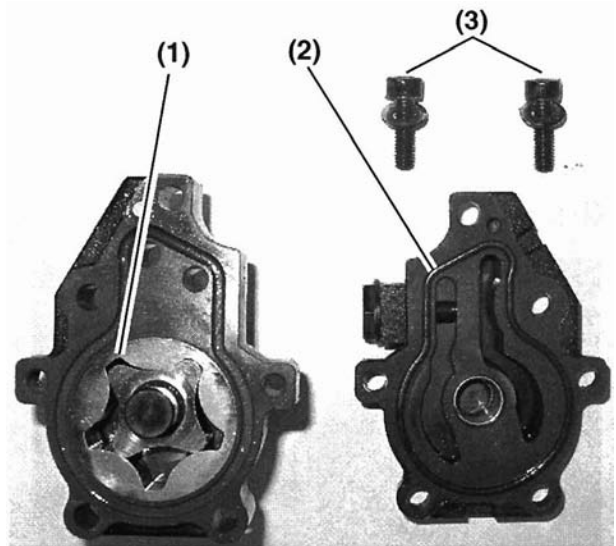

Figure. 5-77

## Charge Pump

Note: If charge pump was disassembled for inspection, clean all parts thoroughly before reassembly. If any part is suspected of damage or failure, replace the complete pump assembly.

- 1. Install and align pump gears (**Figure 5-78, (1)**) into pump housing.
- 2. Install the new pump housing O-ring (**Figure 5-78, (2)**) into groove and assembly pump housings. Tighten the two (5 mm hex) pump housing screws (**Figure 5-78, (3)**) to 6 - 7 ft-lb. (8 - 10 N·m).



0003559A

Figure 5-78

- 3. Install new charge pump housing O-rings (**Figure 5-79, (1)**).

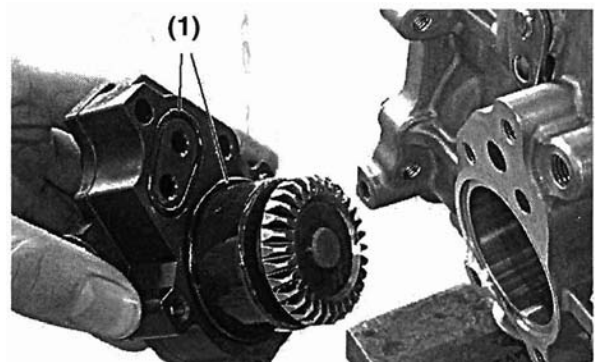
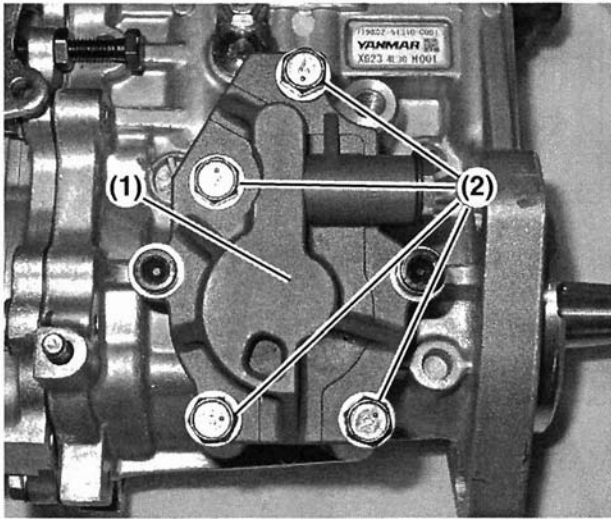

Figure 5-79

4. Install the charge pump (**Figure 5-80, (1)**) and tighten the four mount screws (**Figure 5-80, (2)**) to 6 - 7 ft-lb. (8 - 10 N·m).



0001197a

**Figure 5-80**

## Governor Installation

1. Install the governor weight assembly and nut (**Figure 5-81, (1)**) to the fuel injection pump camshaft.



0001250a

**Figure 5-81**

2. Attach a stop to the camshaft. Tighten the governor weight nut (**Figure 5-82, (1)**) to 58 - 62 ft-lb. (79 - 84 N·m). Install the governor sleeve.

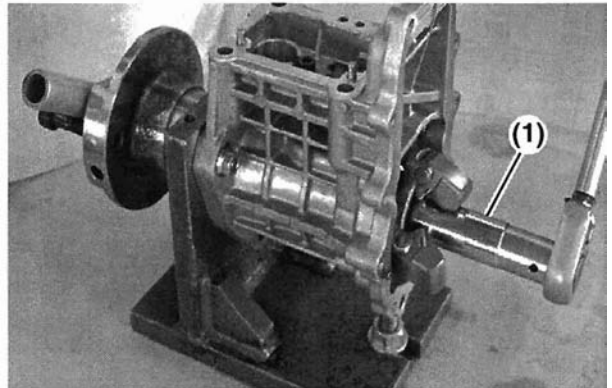

0001251a

**Figure 5-82**

Note: Be careful not to bend or damage the governor housing gasket.

3. Align and install a new governor housing gasket (**Figure 5-83, (1)**).

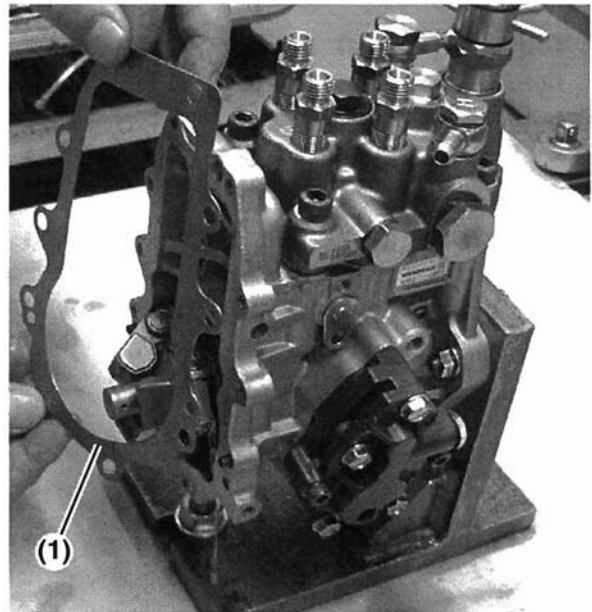

0001300a

**Figure 5-83**



# FUEL INJECTION PUMP

- Turn the link lifter plate counterclockwise to the 6 o'clock position and install the governor assembly and link into the pump body (**Figure 5-84**).

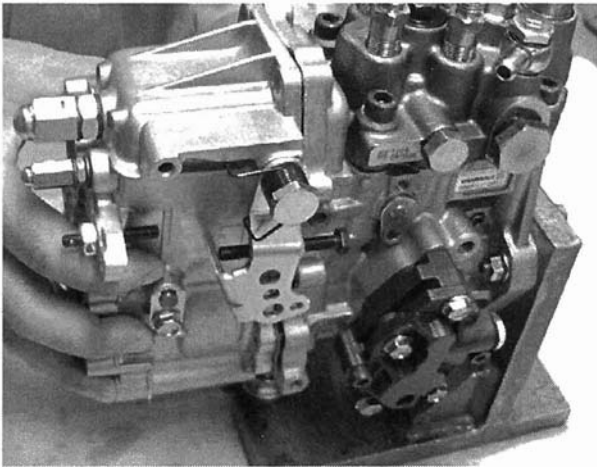

**Figure 5-84**

0001302a

Note: Do not force the link during installation, as damage can occur to the link and control rack pin.

Note: **Figure 5-85** illustrates the governor link connection to the control rack. The actual connection is blind, therefore this illustration is used to assist during assembly.

- While installing the governor assembly, slide the link lifter as shown (**Figure 5-85, 4**), to allow the link to slide in to align with the control rack pin.

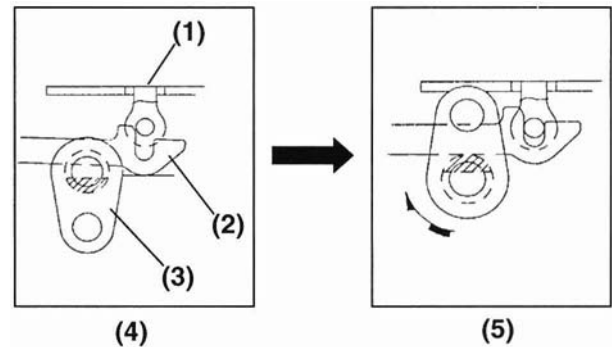

0001301

- |                  |                     |
|------------------|---------------------|
| 1. Control Rack  | 4. During Assembly  |
| 2. Governor Link | 5. During Operation |
| 3. Link Lifter   |                     |

**Figure 5-85**

- Install two governor housing bolts by hand to hold the governor in place.
- While pushing the governor lever assembly to the full stop position through the stop solenoid opening, rotate the link lifter clockwise to the 12 o'clock position.
- Verify the link installation by watching plunger rotation from the top of the hydraulic head. The plunger should rotate in both directions while moving the control rack in and out.
- Install a new copper seal (**Figure 5-86, (3)**), plunger and barrel plug (**Figure 5-86, (1)**) and O-ring (**Figure 5-86, (2)**). Tighten to (MP2 - 22 - 26 ft-lb. (30 - 35 N·m)) (MP4 - 33 - 37 ft-lb. (45 - 50 N·m)).

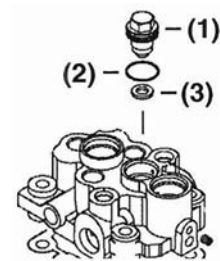

**Figure 5-86**

10. Tighten the link lifter retainer bolt (**Figure 5-87, (1)**) to 6- 7 ft-lb (8 - 10 N·m).

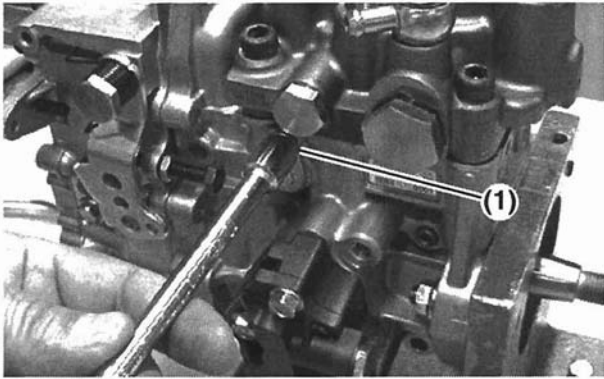

0001304a

**Figure 5-87**

11. Install the governor housing screws and tighten to 6 - 7 ft-lb (8 - 10 N·m) (**Figure 5-88**).

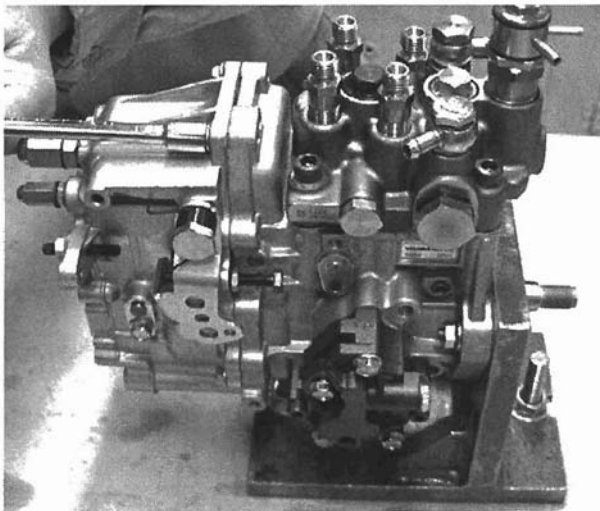

0001305a

**Figure 5-88**

12. Install a new O-ring (**Figure 5-89, (1)**) to the stop solenoid and install the stop solenoid to the governor housing. Tighten the solenoid bolts to 6 - 7 ft-lb (8 - 10 N·m).

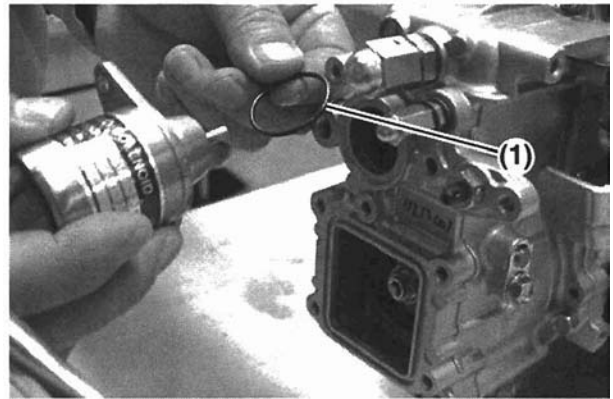

0001306a

**Figure 5-89**

13. Pre-set the adjustment of the angleich assembly, by loosening the angleich lock nut (**Figure 5-90, (1)**).

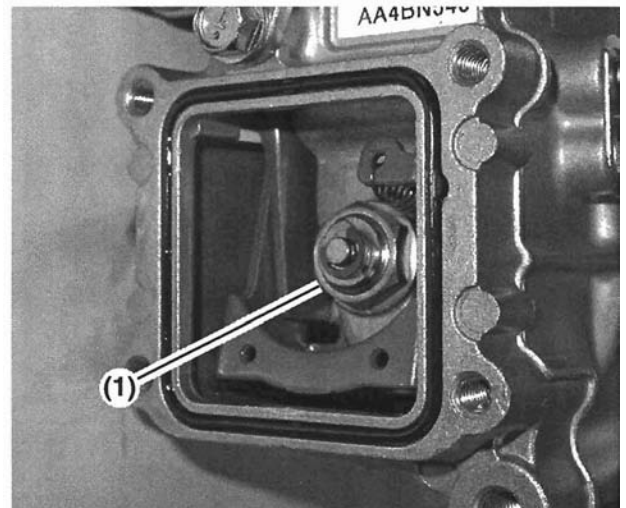

0001306C

**Figure 5-90**

14. Turn the angleich adjustment screw in until it contacts the governor lever and then back out one-quarter (1/4) turn.
15. Tighten the angleich lock nut.

## FUEL INJECTION PUMP

---

16. Install a new governor housing cover gasket (**Figure 5-91**).

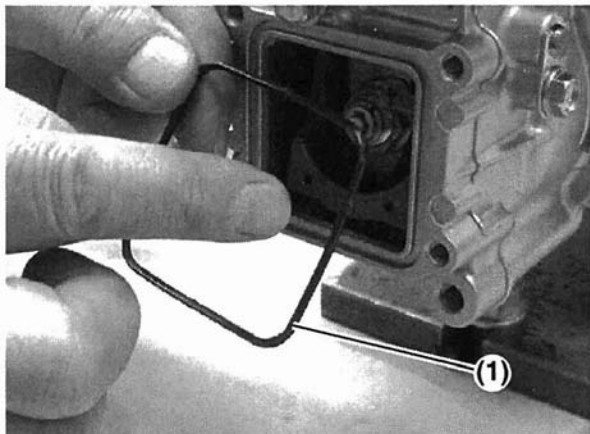

0001307a

**Figure 5-91**

17. Install the governor housing cover to the case (**Figure 5-92**). Tighten the governor housing cover bolts to 6 - 7 ft-lb (8 - 10 N·m).

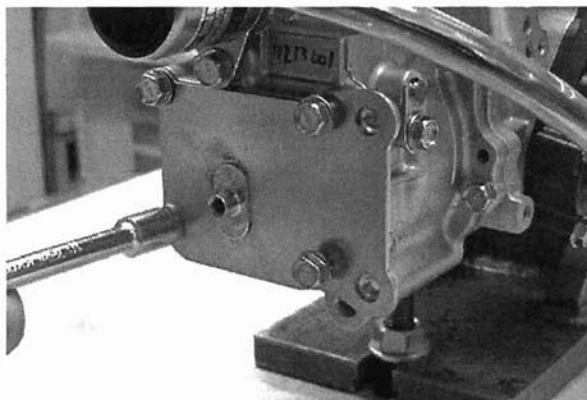

0001308a

**Figure 5-92**

## Section 6

# ADJUSTMENT

---

	Page
Introduction.....	6-3
Setup and Inspection.....	6-3
Adjustment .....	6-4
Component Identification.....	6-4
High Idle Fuel Delivery .....	6-4
Rated Fuel Delivery .....	6-4
Torque Fuel Delivery .....	6-5
Reverse Angleich Spring Adjustment.....	6-5
Low Idle Fuel Delivery .....	6-6
Start Fuel Delivery .....	6-6
Ultra-Low Speed Delivery.....	6-6
Stop Fuel Delivery .....	6-6
Tamper-Proof Cap Installation.....	6-7
Fuel Pump Timing Index Stamping Identification .....	6-7

**This Page Intentionally Left Blank**

## INTRODUCTION

This section of the *Service Manual* describes the adjustment procedures necessary to setup and adjust the fuel injection pump and governor.

The fuel injection pump delivery must be calibrated, whenever the pump is disassembled.

A fuel pump test bench (**Figure 6-1**) is required to make the necessary adjustments.

## SETUP AND INSPECTION

1. Verify adjusting nozzle assembly and injection starting pressure.

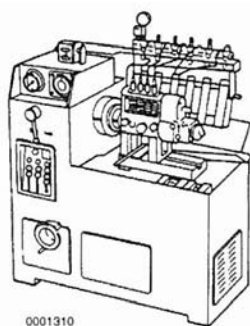

0001310

**Figure 6-1**

Adjusting nozzle type	YDN-12SD12
Injection starting pressure	2350-2495 psi (16.2-17.2 mPa; 165-175 kgf/cm <sup>2</sup> )

2. Inspect the high pressure injection line.

Inner diameter	0.08 in. (2.0 mm)
Outer diameter x length	0.24 x 23.62 in. (6.0 x 600 mm)
Minimum bending radius	0.98 in. (25 mm)

3. Mount the fuel injection pump (**Figure 6-2**) on the pump tester platform.

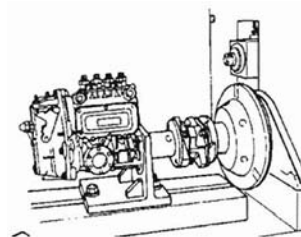

**Figure 6-2**

4. Remove the oil fill plug on the top of the governor case. Fill (**Figure 6-3, (1)**) the pump with about 6.75 oz (200 cc) of pump oil or engine oil.

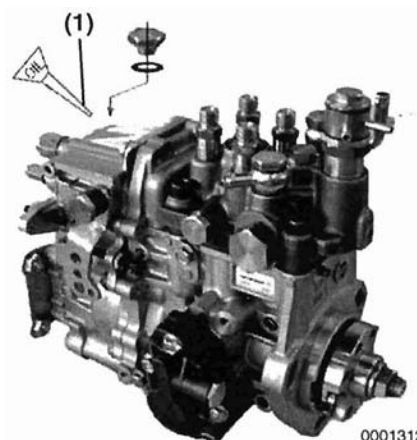

0001312

**Figure 6-3**

5. Securely tighten all fuel lines to the fuel pump and tester.
6. Set the oil feed pressure (**Figure 6-4**) at 2.8-4.3 psi (19.6 - 29.4 kPa, 0.2 - 0.3 kgf/cm<sup>2</sup>), temperature at 40 ± 2°C (104 ± 3.6°F).

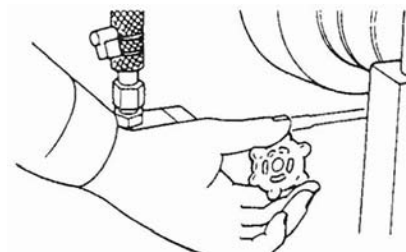

**Figure 6-4**

7. Operate the pump tester to purge the fuel lines of all air.



## ADJUSTMENT

### ADJUSTMENT

The adjustment of fuel delivery requires correct specifications. Before performing any of the adjustments in this section, obtain the correct calibration data sheet for the fuel injection pump being tested. Contact your Yanmar Fuel Injection Equipment Central Distributor to obtain the data sheet.

Adjustments must be performed in the following order when adjusting the governor:

1. High Idle Fuel Delivery
2. Rated Fuel Delivery
3. Torque Fuel Delivery
4. Reverse Angleich Spring Adjustment
5. Low Idle Fuel Delivery
6. Starting Fuel Delivery
7. Stop Fuel Delivery
8. Re-check Rated Fuel Delivery
9. Tamper-Proof Cap Installation

### Component Identification

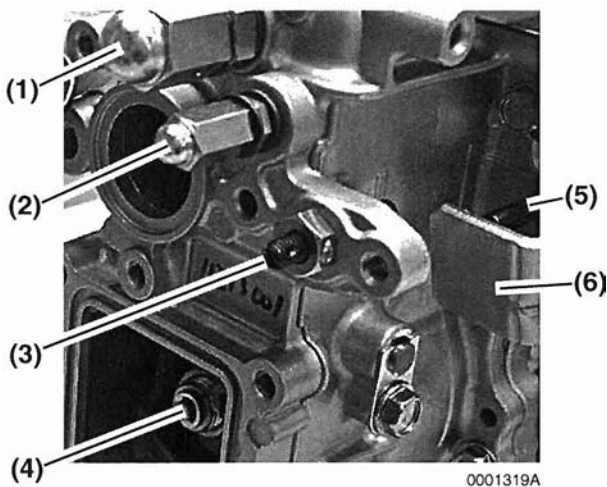

1. Rated Fuel Limiter Adjustment Assembly
2. Starting Fuel Adjustment Assembly
3. High Idle Speed Limit Bolt
4. Reverse Angleich Adjustment Assembly
5. Low Idle Speed Limit Bolt
6. Control Lever

**Figure 6-5**

### High Idle Fuel Delivery

1. Set the fuel pump speed at the high idle speed specified. (See *Calibration Data Sheet*).
2. Set the control lever (**Figure 6-5, (6)**) to the high idle position while turning the high idle speed limit bolt (**Figure 6-5, (3)**) to obtain the specified injection amount. (See *Calibration Data Sheet*).
3. Tighten the lock nut after completing the adjustment to lock the high idle speed limit bolt from turning.

### Rated Fuel Delivery

The MP2 pump has a rated fuel limiter adjustment assembly **Figure 6-6** as standard equipment.

1. Remove the tamper-proof cap and screw in the fuel limiter assembly (**Figure 6-6, (1)**) until it contacts the governor tension lever and then back off one-quarter (1/4) turn.

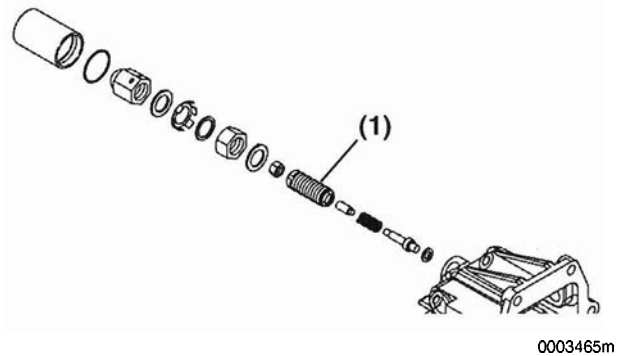

**Figure 6-6**

2. Set the pump speed at the rated speed (see *Calibration Data Sheet*) and move the control lever until it contacts the high idle speed limit bolt (**Figure 6-5, (3)**).
3. Adjust the rated injection amount by turning the fuel limiter assembly (**Figure 6-6, (1)**) in or out to obtain the correct specification, (See *Calibration Data Sheet*).

## Torque Fuel Delivery

Torque fuel delivery adjustment requires adjustment of the fuel limiter torque spring (**Figure 6-7, (3)**) or angleich, when applicable.

1. Set the pump speed at the torque rise speed (*See Calibration Data Sheet*) and move the control lever until it contacts the high idle speed limit bolt.

If the fuel limiter assembly has a torque spring:

- Screw in the fuel limiter torque spring adjustment screw (**Figure 6-7, (4)**) to obtain the specified injection amount (*See Calibration Data Sheet*) and fasten the lock nut.

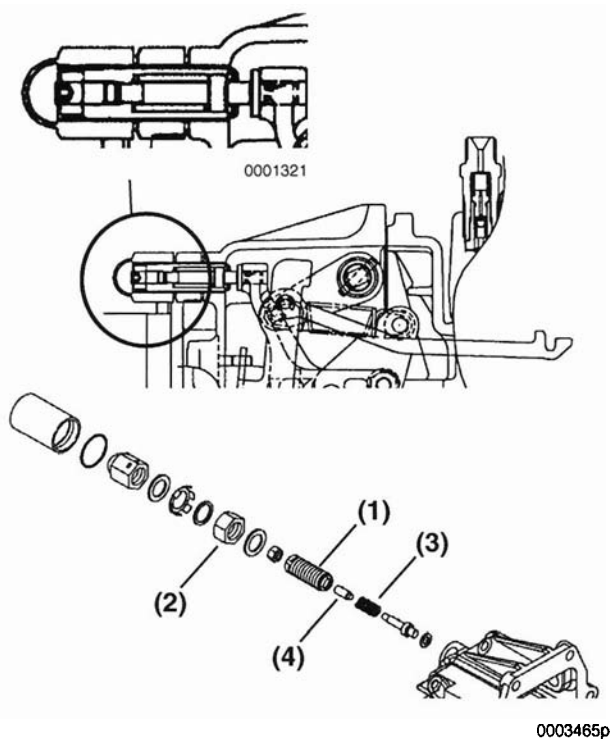

**Figure 6-7**

If the fuel limiter assembly does not have torque spring:

- See *Reverse Angleich Spring Adjustment* on this page.

## Reverse Angleich Spring Adjustment

Note:) Do not thread past the reverse angleich lever or the reverse angleich lever will move in a direction of fuel reduction.

1. With the pump stopped, remove the governor housing rear cover (**Figure 6-9, (1)**) and adjust the angleich assembly (**Figure 6-8, (1)**) until contact is just made with the reverse angleich lever (**Figure 6-9, (4)**).
2. Shift the control lever to the high idle position. Set the fuel pump speed to the specified torque rise RPM number. (*See Calibration Data Sheet*).

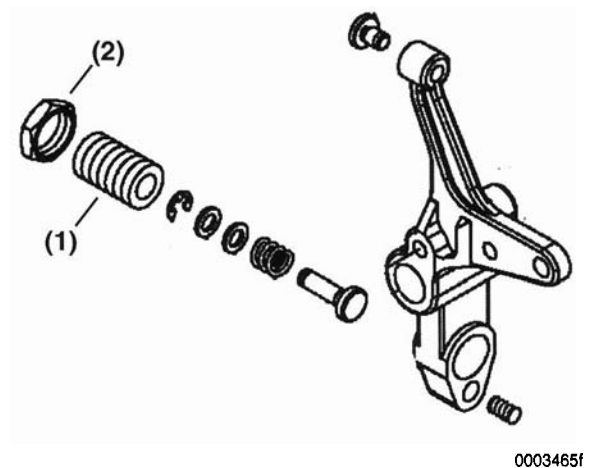
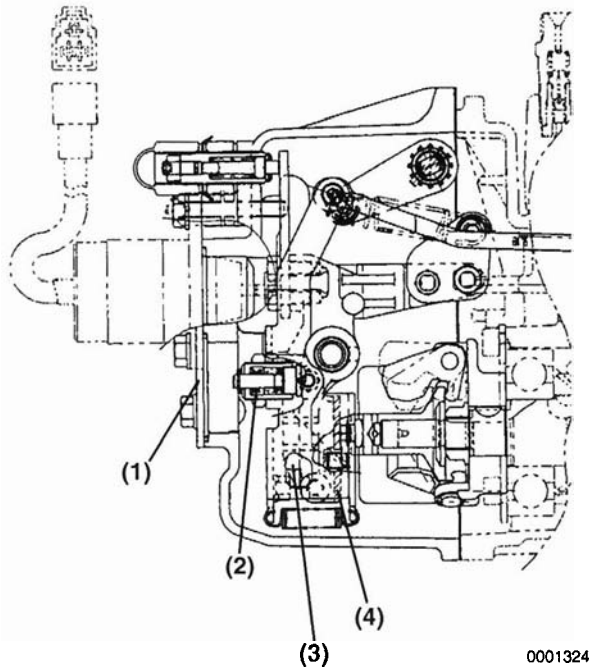

**Figure 6-8**

3. Set the angleich assembly to the specified injection quantity. (*See Calibration Data Sheet*).
4. Tighten the lock nut (**Figure 6-8, (2)**) to 24.5 - 29.4 N·m (2.5 - 3.0 kgf·m).

## ADJUSTMENT

5. Recheck the rated fuel delivery.



- |                            |                           |
|----------------------------|---------------------------|
| 1. Governor Rear Cover     | 3. Governor Tension Lever |
| 2. Reverse Angleich Spring | 4. Reverse Angleich Lever |

**Figure 6-9**

### Low Idle Fuel Delivery

1. Set the pump speed at the low idle pump speed (see *Calibration Data Sheet*) with the control lever (Figure 6-10, (1)) in the idle position.
2. Turn the low idle speed limit bolt (Figure 6-10, (2)) to achieve the correct idling delivery amount. (See *Calibration Data Sheet*)
3. Tighten the lock nut.

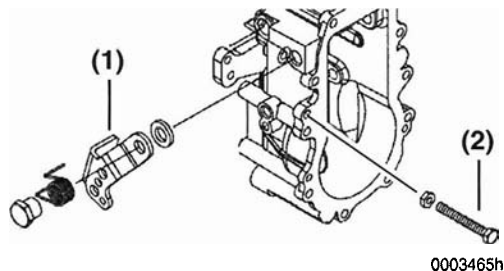

**Figure 6-10**

### Start Fuel Delivery

1. Set the pump speed at the specified starting injection RPM (see *Calibration Data Sheet*), and set the control lever at the high idle position.
2. Turn the starting fuel adjustment bolt (Figure 6-11, (1)) to obtain the specified injection amount. (See *Calibration Data Sheet*)
3. Tighten the locknut (Figure 6-11, (2)) and install the hex cap.

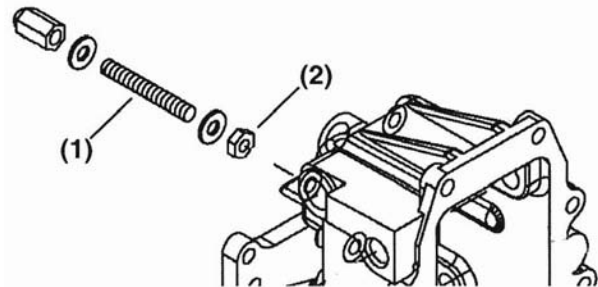

**Figure 6-11**

### Ultra-Low Speed Delivery

1. Set the pump speed at 50 RPM and check the ultra-low speed setting injection volume specification. (See *Calibration Data Sheet*)

Note: The Ultra Low Speed Test checks the condition of the plunger and barrel. Delivery below specifications indicates excessive leakage.

### Stop Fuel Delivery

Set the control lever at the high idle position.

1. Set the pump speed at 50 RPM higher than the specified high idle speed (see *Calibration Data Sheet*) and check that the (governor cut out) injection amount reduces to zero. (See *Calibration Data Sheet*)
2. Set the pump at the rated speed and turn off the stop solenoid and check that the injection amount reduces to zero.

Note: There are a few turbo charged engines that incorporate a boost compensator on the governor assembly. Additional calibration data, procedures and adjustments can be found in the calibration data field of the Yanmar Distributor Web Site.

## Tamper-Proof Cap Installation

1. Install a new tab washer (**Figure 6-12, (1)**) and tamper-proof cap (**Figure 6-12, (2)**) on the fuel limiter assembly.
2. Install a new tamper-proof cap (**Figure 6-13, (1)**) on the high idle adjustment assembly.

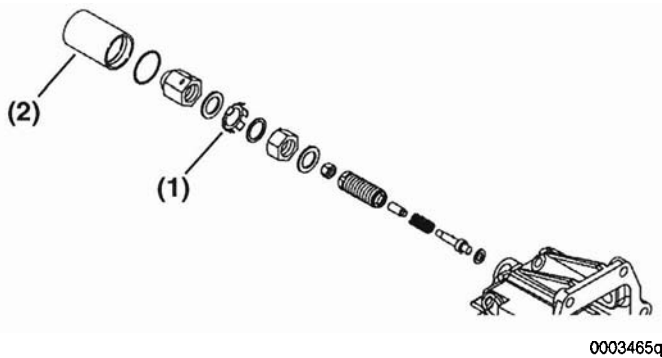

**Figure 6-12**

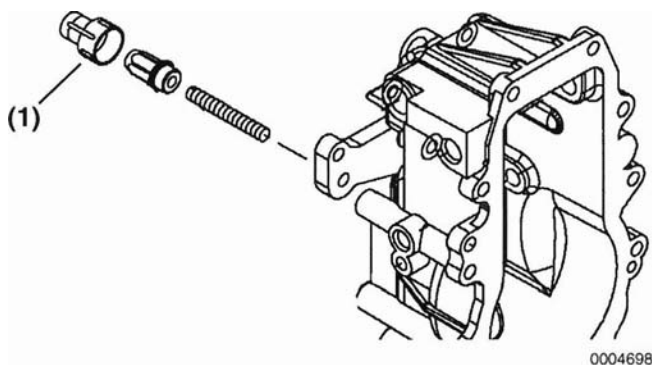

**Figure 6-13**

## Fuel Pump Timing Index Stamping Identification

The timing index numbers stamped on the original fuel pump hydraulic head are needed for the engine technician to set fuel injection timing.

Replacement hydraulic heads do not have the necessary timing index numbers stamped on the engine side boss like the original fuel pumps. The timing index numbers are needed to properly set injection timing when reinstalling the fuel injection pump.

Upon completion of fuel pump repairs when the hydraulic head is replaced the correct timing index number must be manually stamped (**Figure 6-14, (1)**) onto the boss on the engine side of the hydraulic head.

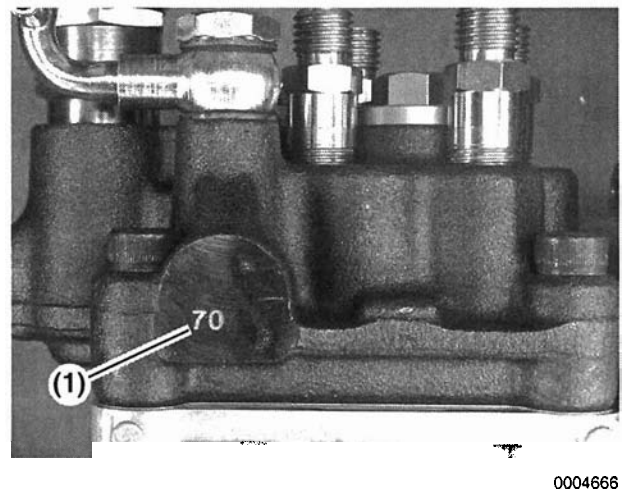

**Figure 6-14**

The correct timing index number can be found on the Yanmar Distributor Web Site under the "F.I.E." heading or under the document search function. Use category F.I.E. to locate the timing Index Information for replacement of the MP Fuel Injection Pump. ISD-05-001, Page 4.

**This Page Intentionally Left Blank**

## Section 7

# FUEL INJECTION NOZZLE

---

	Page
Introduction.....	7-2
Specifications .....	7-2
Nozzle Body Identification Number .....	7-3
Special Torque Chart .....	7-4
Special Service Tools.....	7-4
Measuring Instruments.....	7-4
Fuel Injection Nozzle .....	7-5
Operation.....	7-5
Disassembly .....	7-6
Cleaning .....	7-7
Inspection .....	7-7
Reassembly.....	7-8
Opening Pressure Adjustment.....	7-8
Injection Test.....	7-8



# FUEL INJECTION NOZZLE

## INTRODUCTION

This section of the *Service Manual* describes the operation and procedures necessary to disassemble and reassemble the fuel injection nozzles.

Yanmar MP fuel injection pumps are designed for use on TNV (DI) Direct Injection engines, equipped with hole type nozzles. A list of Yanmar MP fuel injection pump equipped engines is provided in the following chart.

### Yanmar Engines equipped with MP Fuel Injection Pumps

MP2	3TNV82A	
	3TNV84	3TNV84T
	3TNV88	
	4TNV84	4TNV84T
	4TNV88	
MP4	4TNV94L	
	4TNV98	4TNV98T
	4TNV106	4TNV106T

## SPECIFICATIONS

All TNV fuel injectors have a three character identification mark (**Figure 7-1, (1)**). The first character starts with "V" or "W".

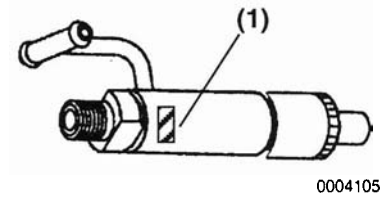

Figure 7-1

Model	Engine Class	Injector ID mark	Fuel Injector Opening Pressure
3TNV82A 4TNV88	CL	W	2843 - 2988 psi (19.6 - 20.6 MPa; 200 - 210 kgf/cm <sup>2</sup> )
3TNV82A 4TNV88	VM	W*	2843 - 2988 psi (19.6 - 20.6 MPa; 200 - 210 kgf/cm <sup>2</sup> )
		or	or
3TNV84AT 4TNV84T		V*	3133 - 3278 psi (21.6 - 22.6 MPa; 220 - 230 kgf/cm <sup>2</sup> )
4TNV94L 4TNV106 4TNV98T 4TNV106T	CL VM	V	3133 - 3278 psi (21.6 - 22.6 MPa; 220 - 230 kgf/cm <sup>2</sup> )

- \* Fuel injector identification is critical as each engine has a unique fuel injection pressure. The fuel nozzle is specifically matched to the fuel injector by engine model and engine speed.

Note: Fuel injection pressure of a new fuel injector is reduced approximately 72.5 psi (0.5 MPa; 5.0 kgf/cm<sup>2</sup>) after about 5 hours of operation due to the initial break in of the spring.

When adjusting a new fuel injector or after it has been disassembled for service, adjust the fuel injector 72.5 psi (0.5 MPa; 5.0 kgf/cm<sup>2</sup>) higher than the above standard.

## NOZZLE BODY IDENTIFICATION NUMBER

The type of nozzle can be determined from the identification number (**Figure 7-1, (1)**) inscribed on the outside of the nozzle body.

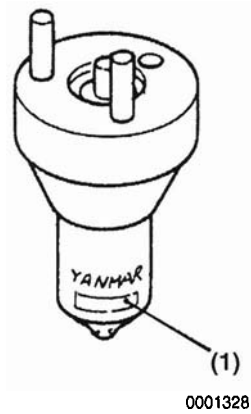

**Figure 7-1**

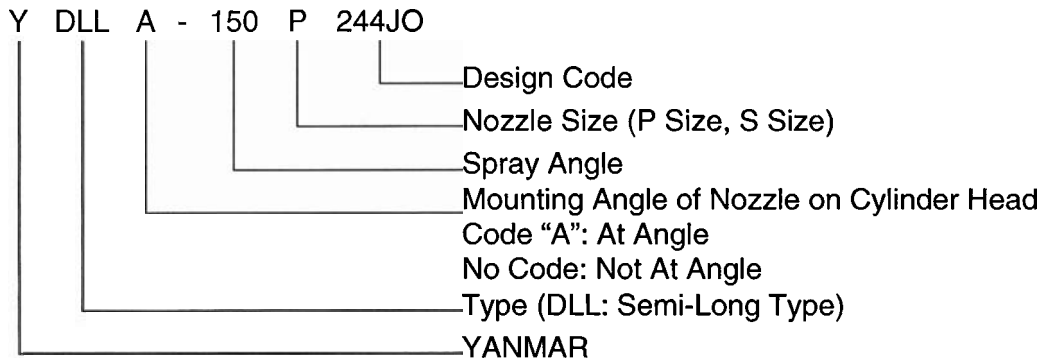



# FUEL INJECTION NOZZLE

## SPECIAL TORQUE CHART

Component	Tightening Torque	Lubricating Oil Application (Thread Portion and Seat Surface)
Fuel Injector Nozzle Case Nut	29 - 33 ft-lb (39 - 44 N·m; 4 - 5 kgf·m)	Not Applied

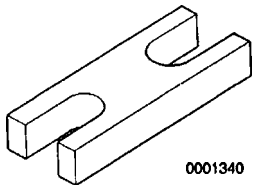
## SPECIAL SERVICE TOOLS

No.	Tool Name	Application	Illustration
1.	Fuel Nozzle Mount Plate Yanmar Part No. 158090-51700	For holding and protecting fuel nozzle when servicing	 0001340
2.	Ultra-Sonic Parts Cleaner (Locally Available)	For cleaning parts	 0004195

Note: Tools not having Yanmar part numbers must be acquired locally.

## MEASURING INSTRUMENTS

No.	Instrument Name	Application	Illustration
1.	Fuel Injector Tester (Locally Available)	For observing injection spray pattern of fuel injection nozzle and measuring injection pressure	

Note: Tools not having Yanmar part numbers must be acquired locally.

# FUEL INJECTION NOZZLE

## Operation

High pressure fuel from the fuel injection pump flows through the high pressure pipe into the oil passage in the nozzle housing and enters the nozzle body reservoir.

When the fuel reaches the specified pressure, it pushes open the nozzle valve (held down by spring pressure) and is injected into the combustion chamber at high pressure. Injection nozzle opening pressure is adjusted using shims to increase or decrease the spring pressure on the nozzle valve. (See *Opening Pressure Adjustment* on page 7-8)

As fuel passes through the nozzle, it is atomized to mix uniformly with the air in the combustion chamber. How well the fuel is mixed with high temperature air directly affects combustion efficiency, engine performance and fuel economy.

Note: Fuel injection nozzles must be kept in top condition to maintain performance and operating efficiency.

The nozzle valve is automatically closed by the nozzle spring pressure at the end of the fuel injection pump stroke.

Unused fuel between the nozzle valve and nozzle body flows from the hole above the nozzle spring through the fuel return fitting and back into the fuel tank.

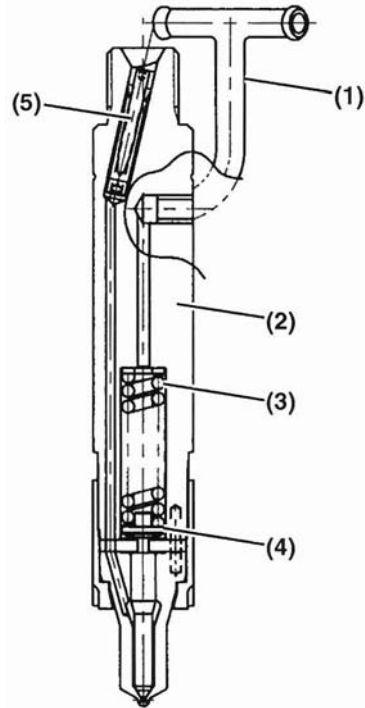

0001326A

- |                        |                             |
|------------------------|-----------------------------|
| 1. Fuel Return Fitting | 4. Nozzle Spring Seat       |
| 2. Nozzle Housing      | 5. Filter (Non-serviceable) |
| 3. Nozzle Spring       |                             |

Figure 7-2

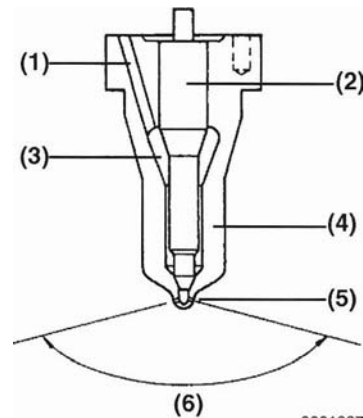

0001327

- |                   |                   |
|-------------------|-------------------|
| 1. Reservoir Port | 4. Nozzle Body    |
| 2. Nozzle Valve   | 5. Injection Port |
| 3. Fuel Reservoir | 6. Spray Angle    |

Figure 7-3

# FUEL INJECTION NOZZLE

## Disassembly

Note: Keep all parts in order by cylinder during disassembly and reinstall all small parts to their mating part as the components as components are matched.

1. Mount the hole type injection nozzle into the YANMAR special fuel nozzle mount plate P/N 158090-51700 (**Figure 7-4, (2)**). Carefully mount the holder and nozzle in to a vise (**Figure 7-4, (3)**) to ensure the high pressure mounting threads are not damaged.
2. Use a socket wrench (**Figure 7-4, (1)**) to remove the nozzle nut.

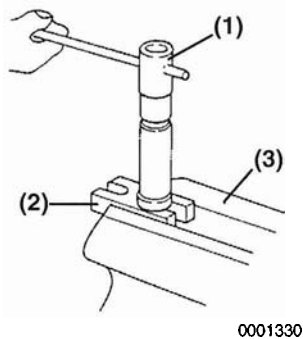

**Figure 7-4**

3. Remove all nozzle components including the spring seat and shims.

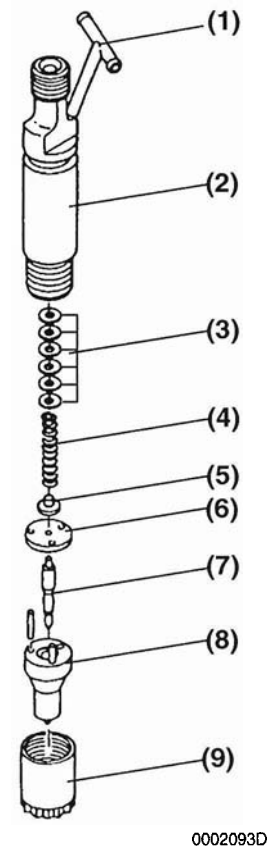

1. Fuel Return Passage
2. Injector Body
3. Pressure Adjusting Shims
4. Spring
5. Spring Seat
6. Valve Stop Spacer
7. Nozzle Valve
8. Nozzle Body
9. Nozzle Case Nut

**Figure 7-5**



## Cleaning

Note: Before inspecting or assembling, all components must be washed with clean diesel fuel or standard cleaning solution and completely clean and free of contaminants.

1. Clean carbon from outside of nozzle body using a brass brush.
2. Clean nozzle opening with small length of deburred steel 0.0055 in. (0.14 mm) wire (**Figure 7-6, (1)**).

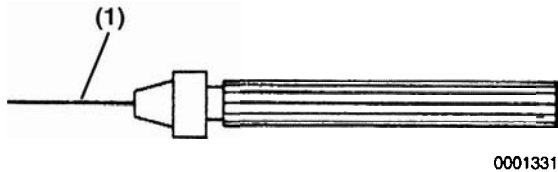

**Figure 7-6**

3. Clean nozzle seat with cleaning spray.

Note: An ultra sonic cleaner can be used to effectively clean the injector body and inner components after loose material is removed.

## Inspection

1. Inspect oil seal surfaces for abnormal scratches or wear, replace as necessary.
2. Inspect nozzle body for scratches and wear on nozzle body and tip. Replace the nozzle if the nozzle sliding surface or seat are scratched or abnormally worn.
3. Rotate and slide the nozzle to check for smooth movement (**Figure 7-8**), replace the nozzle assembly if the nozzle does not slide smoothly.



**Figure 7-7**

4. Inspect the nozzle valve stop for scratches and/or wear at the sealing surfaces on both sides. Check for abnormal wear at stop plate center hole where it makes contact with the nozzle (**Figure 7-8, (1)**), replace if worn.

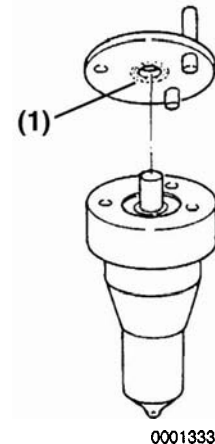

**Figure 7-8**

5. Inspect the nozzle spring, replace it if deformed, or the surface is scratched or rusted.

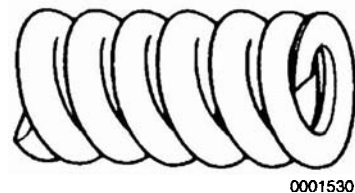

**Figure 7-9**

6. Inspect the nozzle oil sealing surface for scratches and/or wear, replace it if wear is excessive.

# FUEL INJECTION NOZZLE

## Reassembly

The fuel injection nozzle is assembled in the reverse order of disassembly.

1. Insert the adjusting shims, spring and spring seat in the nozzle holder, mount the nozzle valve stop plate with the pin, insert the nozzle assembly and tighten the nozzle case nut.
2. Use the nozzle holder when tightening the case nut to 28.8 - 32.5 ft-lb (39 - 44 N·m, 4 - 5 kgf·m).

## Opening Pressure Adjustment

Mount the fuel injection nozzle on the nozzle tester (Figure 7-10, (1)) and use the handle to measure injection opening pressure. If it is not at specified pressure, add or remove adjusting shims to increase or decrease the pressure, see *Specifications on page 7-2* for fuel injector opening pressures.

Note: Adjusting by 0.004 in (0.1 mm) results in a change in the injection opening pressure of about 290 psi (2 MPa, 20 kgf/cm<sup>2</sup>)

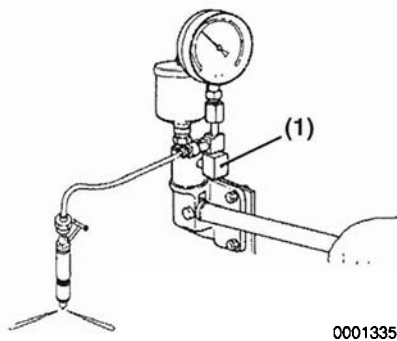

Figure 7-10

## Injection Test

After adjusting the nozzle to the specified opening pressure, check the fuel spray condition and make sure the nozzle does not leak.

1. Check the injection spray condition, by operating the nozzle tester lever once or twice per second to check for abnormal injection.

### Correct

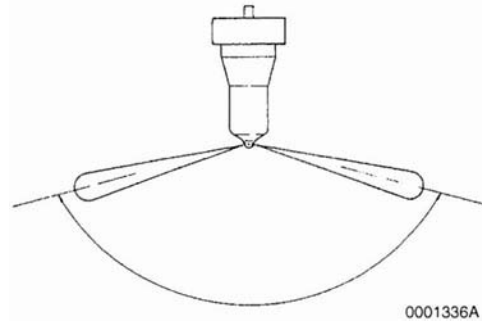

- Spray from each nozzle hole is uniform.
- Spray is fully atomized (no streams of fuel).
- Start and stop of injection is "sharp" (a clean chatter sound should be heard).

### Poor

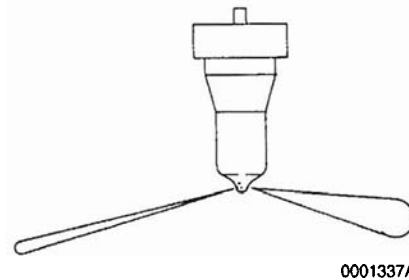

- Excessive difference in spray angle.
- Incomplete atomization  
Causes - Incomplete opening/closing of injection nozzle.

Figure 7-11

2. Check that the nozzle tip is not leaking after two or three injections, then gradually increase the pressure up to 200 psi (1.38 MPa; 14.06 kg/cm<sup>2</sup>). Maintain the pressure for 5 seconds and make sure that no oil is dripping from the opening pass the nozzle.

3. Replace the nozzle assembly after all checks above if:
  - Leakage is evident.
  - Spray angle is incorrect.
  - Atomization of fuel is incomplete.
  - Opening and closing of nozzle is incomplete.

**This Page Intentionally Left Blank**

## Section 8

# **TROUBLESHOOTING**

	<b>Page</b>
Introduction.....	8-2
Troubleshooting.....	8-2
Preliminary Checks.....	8-2
Fuel System Troubleshooting Chart.....	8-3



# TROUBLESHOOTING

---

## INTRODUCTION

This section of the *Service Manual* includes troubleshooting procedures and troubleshooting charts used in the diagnosis of the fuel injection pump and fuel system problems.

## TROUBLESHOOTING

Troubleshooting a fuel system related problem involves:

- Identifying the problem accurately.
- Duplicating the problem.
- Correctly identifying the cause of the problem.
- Correcting the problem.
- Eliminating the cause of the damage.
- Repairing the damage.
- Verify corrections made have corrected the initial problem.

### Preliminary Checks

To quickly and accurately troubleshoot fuel system problems, the following preliminary checks should be performed before the fuel injection pump is removed. When possible provide troubleshooting assistance to the customer, before the fuel injection pump is removed. This will prevent unnecessary costs that can result from an incorrect diagnosis.

If the pump is removed prematurely, the initial cause of the problem may never be known.

- Check the mechanical condition of the engine.
- Check the condition of the fuel type and quality, fuel flow, and fuel pressure throughout the fuel system.
- Check for restrictions and leaks throughout the fuel system.
- Verify fuel injection timing is within specifications.
- Verify fuel nozzle operation and nozzle spray condition.

### Fuel Injection Pump Repair

- If the fuel injection pump is found to be faulty, remove it from the engine for repair.
- It is very important that the root cause of the failure is eliminated before installing and / or repairing the fuel injection pump.

## FUEL SYSTEM TROUBLESHOOTING CHART

Use this troubleshooting chart to assist in the diagnosis of the fuel system prior to removing the fuel injection pump.

Complaint		Cause	Correction
1. Engine won't start.	Fuel not delivered to injection pump.	(1) No fuel in the fuel tank.	Fill with fuel.
		(2) Fuel tank valve is closed.	Open.
		(3) Fuel line or valve is clogged.	Clean complete fuel system.
		(4) Fuel filter element is clogged.	Disassemble and clean, or replace element. Find and repair source of debris in fuel.
		(5) Air in fuel lines.	Locate air leak using clear fuel line and repair.
		(6) Fuel feed pump inoperable.	Replace.
		(7) Fuel has gelled.	Replace with a fuel for cold weather or use fuel heater.
	Fuel delivered to injection pump.	(1) Stop solenoid is Inoperative.	Determine cause and repair or replace solenoid.
		(2) Throttle control inoperative.	Repair or adjust.
		(3) Air in fuel lines.	Locate air leak using clear fuel line and repair.
		(4) Low cranking speed.	Check battery, starter motor or internal engine components for failure.
		(5) Internal failure of injection pump.	Remove pump and repair.
		(6) Governor is damaged.	Remove governor and repair or replace.
		(7) Injection pump coupling, gear or key is damaged.	Replace.
		(8) Lifter is seized.	Check lube oil supply and oil pump. Repair pump.
		(9) Cold start device is inoperative.	Repair device.
		(10) Transmission shaft is seized. Gear slip.	Repair pump.
	Nozzle inoperative.	(1) Compression leakage past injector.	Replace nozzle seat and tighten retainer to specifications.
		(2) Fuel leakage from nozzle.	Tighten case nut to specification.
		(3) One or more nozzles are sticking open or closed.	Determine cause of nozzle failure and repair.
	Injection timing is defective.	(1) Injection pump is installed incorrectly.	Reinstall pump and time engine.
		(2) Injection timing is excessively advanced or retarded due to failed key or coupler.	Replace key or coupler.
		(3) Internal failure of injection pump.	Remove pump and repair.

# TROUBLESHOOTING

Complaint		Cause	Correction
2. Engine starts, but immediately stops.		(1) Engine is out of fuel.	Fill with fuel.
		(2) Fuel filter element is clogged.	Disassemble and clean, or replace element. Find and repair source of debris in fuel.
		(3) Fuel line is clogged.	Clean complete fuel system.
		(4) Air in fuel lines.	Locate air leak using clear fuel line and repair.
		(5) Insufficient fuel delivery from the feed pump.	Repair or replace.
		(6) Stop solenoid is defective.	Replace.
		(7) Charge pump is defective.	Replace.
3. Engine output is insufficient.	Defective injection timing, and other failures.	(1) Type of fuel is incorrect.	Check and refill with proper fuel.
		(2) Insufficient fuel delivery from feed pump.	Repair or replace.
		(3) Fuel temperature is high.	Determine cause of high fuel temperature and repair.
		(4) Knocking sounds caused by improper (too fast) injection timing.	Inspect and adjust.
		(5) Engine overheats or emits large amount of smoke due to improper (too slow) injection timing.	Inspect and adjust.
		(6) Charge pump is defective.	Replace.
	Nozzle movement is defective.	(1) Defective injection nozzle performance.	Repair or replace nozzle.
		(2) Case nut is loose.	Inspect and retighten.
		(3) Nozzle spring is broken.	Replace.
		(4) Excessive oil leaks from nozzle.	Replace nozzle assembly.
	Fuel Injection pump is defective.	(1) Plunger is worn.	Replace hydraulic head and filters.
		(2) Fuel limiter improperly tampered with by operator.	Calibrate pump to specifications.
		(3) Delivery holder is loose	Inspect and retighten.
		(4) Delivery valve seat is defective.	Repair or replace.
		(5) Delivery packing is defective.	Replace packing.
(6) Delivery spring is broken.		Replace.	

Complaint		Cause	Correction
4. Rough idle.		(1) Air in fuel lines.	Locate air leak using clear fuel line and repair.
		(2) Fuel filter clogged.	Disassemble and clean, or replace element.
		(3) Poor feed pump performance.	Repair or replace.
		(4) Delivery holder is too tight.	Inspect packing and torque to specifications.
		(5) Plunger is worn and fuel injection adjustment is difficult.	Replace hydraulic head and filters.
		(6) Movement of control rack is defective	Repair or replace.
		(6 a) Stiff plunger movement or sticking.	Repair or replace.
		(6 b) Rack and guide is defective.	Repair.
		(6 c) Poor delivery valve operation.	Replace
		(7) Movement of governor is improper.	Repair.
		(7 a) Shifter is worn.	Replace.
		(7 b) Governor spring is too weak.	Replace.
		(7 c) Governor weight assembly worn.	Replace.
	(8) One or more faulty nozzles.	Repair or replace nozzles and filters.	
	(9) Charge pump is worn.	Replace.	
5. Engine operates normal at high RPM, but runs rough and or stalls at low RPM.		(1) Low idling stopper bolt is abnormal.	Replace or adjust.
		(2) Calibration of low speed incorrect.	Inspect and calibrate pump.
6. Engine not achieving maximum RPM.		(1) Throttle improperly adjusted.	Adjust.
		(2) High speed stop improperly set.	Calibrate pump.
		(3) Fuel supply inadequate.	Repair / replace feed pump or filter.
		(4) One or more nozzles defective.	Repair or replace.
		(5) Plunger is worn.	Replace Hydraulic head.
		(6) Governor spring is worn.	Replace.
		(7) Charge pump is defective.	Replace.
7. Loud engine knocking sound.		(1) Injection timing is too fast.	Adjust.
		(2) Injection from nozzle is improper, fuel drips after each injection.	Repair or replace nozzle.
		(3) Injection nozzle starting pressure is too high.	Adjust.
		(4) Engine overheats.	Repair cooling system.
8. Engine emits excessive smoke.	When exhaust smoke is black:	(1) Injection timing is too fast.	Adjust.
		(2) Air volume intake is insufficient.	Inspect and repair.
		(3) Injection from nozzle is improper.	Repair or replace.
	When exhaust smoke is white:	(1) Injection timing is too slow.	Adjust.
		(2) Water in fuel.	Inspect fuel system, and clean.
	(3) Coolant leaking into cylinders.	Inspect engine block, cylinder head and head gasket for leakage of coolant into combustion area.	
	(5) Engine is over-cooled.	Inspect cooling system.	

**This Page Intentionally Left Blank**